

Optoelectronică

Curs 9

2023/2024

Disciplina 2023/2024

- ▶ 2C/1L Optoelectronică **OPTO**
- ▶ **Minim 7 prezente curs + laborator**
- ▶ Curs – conf. **Radu Damian**
 - an IV μ E
 - Marti 14(:10)–16:00, P8
 - E – 70% din nota (50%+20%)
 - **20% test (VP) la curs**, saptamana 4–6?
 - probleme + (2p prez. curs)
 - toate materialele permise
- ▶ Laborator – **drd. Stefan Stoica**
 - an IV μ E
 - Marti 16–20 par
 - Max. 7 prezente
 - L – 30% din nota (+Caiet de laborator)

Cuprins

- ▶ **Lumina ca undă electromagnetică*** (ecuațiile lui Maxwell, ecuația undelor, parametri de propagare)
- ▶ **Elemente de fotometrie și radiometrie*** (mărimi energetice/luminoase)
- ▶ **Fibra optică** (realizare, principiu de funcționare, atenuare, dispersie, banda de frecvență)
- ▶ **Cabluri optice** (tehnologie, conectori, lipire – splice)
- ▶ **Proiectare sistemică a legăturii pe fibra optică** (bandă de frecvență, balanța puterilor)
- ▶ **Emitătoare optice** (LED și dioda laser – realizare fizică și funcționare)
- ▶ **Receptoare optice** (dioda PIN, dioda cu avalanșă – realizare fizică și funcționare)
- ▶ **Amplificatoare transimpedanță** (parametri, scheme tipice, TIA în buclă deschisă, cu reacție, diferențiale, control automat al câștigului)
- ▶ **Realizarea circuitelor pentru controlul emițătoarelor optice** (parametri, scheme tipice, controlul puterii, multiplexoare)
- ▶ **Dispozitive de captare a energiei solare** (principiu de funcționare, utilizare, proiectare)

* – VP

Documentatie



English | Romana |

[Main](#) [Courses](#) [Master](#) [Staff](#) [Research](#) [Students](#)

Microwave and Optoelectronics Laboratory

We are enlisted in the Telecommunications Department of the Electronics, Telecommunication and Information Technology Faculty (ETIT) from the "Gh. Asachi" Technical University (TUIASI) in Iasi, Romania

We currently cover inside ETIT the fields related to:

- Microwave Circuits and Devices
- Optoelectronics
- Information Technology

Courses

Nr.	Course	Shortcut	Code	Type	Semester	Credits	Weekly	Examination	Link
1	Microwave Devices and Circuits for Radiocommunications	DCMR	DOS412T	DOS	7	4	0P,1L,0S,2C	Exam	details
2	Monolithic Microwave Integrated Circuits	CIMM	RD.IA.207	DOMS	11	6	1.5L,0S,2C,0P	Exam	details
3	Advanced Techniques in the Design of the Radio-communications Systems	TAPSR	RD.IA.103	DIMS	9	6	1.5P,0L,0S,2C	Exam	details
4	Optical Communications	CO	DOS409T	DOS	7	5	0P,1L,0S,3C	Colloquium	details
5	Optical Communications	OC	EDOS409T	DOS	7	5	0P,1L,0S,3C	Exam	details
6	Satellite Communications	CS	RC.IA.104	DIMS	9	6	0L,0S,2C,1.5P	Exam	details
7	Applied Informatics 1	IA1	DOF135	DOF	1	4	0P,1L,0S,2C	Verification	details
8	Applied Informatics 1	AI1	EDOF135	DOF	1	4	0P,1L,0S,2C	Verification	details
9	Databases, Web Programming and Interfacing	DWPI	ITT.IA.601	DIS	11	5	1P,1L,0.25S,1C	Verification	details
10	Web Applications Design	PAW	RC.IA.108	DIMS	10	5	1L,0S,1.5C,1P	Exam	details
11	Optoelectronics	OPTO	DID405M	DID	8	4	0P,1L,0S,2C	Colloquium	details
12	Microwave Devices and Circuits for Radiocommunications (English)	MDCR	EDOS412T	DOS	8	4	0P,1L,0S,2C	Exam	details



Documentatie

- ▶ RF-OPTO
 - <http://rf-opto.etti.tuiasi.ro>
- ▶ Fotografie
 - “examen” online
 - necesara la laborator/curs

Bonus (~0.5–4.15)

Disciplina: Optoelectronica, structuri, tehnologii, circuite

An: 2015/2016

Bonus-uri care se aplica la nota de la teza obtinute prin:

- prezenta la curs (0.5p / 3pr)
- 3 miniteste aplicate la curs (max. 3 X 1.5p)
- contributie la site rf-opto (foto <C5=1p, >C5=0.5p)

Nr.	Student	Grupa	Prezente curs	Bonus prezenta	Bonus foto	Bonus T1	Bonus T2	Bonus T3	Total Bonus	Obs.
1	CIOLPAN OCTAVIAN	5306	3	0.5					0.5	-
2	NITA COSTEL-CATALIN	5307	4	0.5	1				1.5	-
3	BARON BOGDAN-IONUT	5405	12	2	1	0.5		0.75	4.25	-

Prezenta

[Curs](#)
[Laborator](#)

Liste

[Studenti care nu pot intra in examen](#)
[Bonus-uri acumulate](#)

- ▶ **Minim** 7 prezente
- ▶ 0.5p/3prez
- ▶ 3 teste
- ▶ foto <C**7**/ <C**9**

LED

Dioda electroluminescenta

Capitolul 7

Cuprins

- ▶ **Lumina ca undă electromagnetică** (ecuațiile lui Maxwell, ecuația undelor, parametri de propagare)
- ▶ **Elemente de fotometrie și radiometrie** (mărimi energetice/luminoase)
- ▶ **Fibra optică** (realizare, principiu de funcționare, atenuare, dispersie, banda de frecvență)
- ▶ **Cabluri optice** (tehnologie, conectori, lipire – splice)
- ▶ **Proiectare sistemică a legăturii pe fibra optică** (bandă de frecvență, balanța puterilor)
- ▶ **Emițătoare optice** (LED și dioda laser – realizare fizică și funcționare)
- ▶ **Receptoare optice** (dioda PIN, dioda cu avalanșă – realizare fizică și funcționare)
- ▶ **Amplificatoare transimpedanță** (parametri, scheme tipice, TIA în buclă deschisă, cu reacție, diferențiale, control automat al câștigului)
- ▶ **Realizarea circuitelor pentru controlul emițătoarelor optice** (parametri, scheme tipice, controlul puterii, multiplexoare)
- ▶ **Dispozitive de captare a energiei solare** (principiu de funcționare, utilizare, proiectare)

Aplicatii majore LED

- ▶ Comunicatii
 - Infrarosu (InGaAsP)
- ▶ Vizibil
 - Spectru vizibil (GaAlAs)
- ▶ Iluminare
 - Putere ridicata, lumina alba (GaN)

LED – Principiul de operare

- ▶ Lumina este generata de o recombinare radiativa dintre un electron si un gol
- ▶ Recombinarea neradiativa transforma energia in caldura
- ▶ Eficienta cuantica $\eta = \frac{R_r}{R_r + R_{nr}}$
- ▶ La recombinarea radiativa $E_g = h\nu; \lambda = \frac{hc}{E_g}$
- ▶ Recombinare eficienta:
 - alegerea judicioasa a materialului
 - concentrarea purtatorilor in zona jonctiunii
- ▶ Lungimea de unda depinde de temperatura de functionare a dispozitivului: $0.6\text{nm}/^\circ\text{C}$

Lățimea benzii interzise/lungime de undă pentru materialele uzuale

Material	Formula	Wavelength Range λ (μm)	Bandgap Energy W_g (eV)
Indium Phosphide	InP	0.92	1.35
Indium Arsenide	InAs	3.6	0.34
Gallium Phosphide	GaP	0.55	2.24
Gallium Arsenide	GaAs	0.87	1.42
Aluminium Arsenide	AlAs	0.59	2.09
Gallium Indium Phosphide	GaInP	0.64-0.68	1.82-1.94
Aluminium Gallium Arsenide	AlGaAs	0.8-0.9	1.4-1.55
Indium Gallium Arsenide	InGaAs	1.0-1.3	0.95-1.24
Indium Gallium Arsenide Phosphide	InGaAsP	0.9-1.7	0.73-1.35

$$E_g = h\nu; \quad \lambda = \frac{hc}{E_g}; \quad \lambda[\mu\text{m}] = \frac{1.240}{E_g[\text{eV}]}$$

- ▶ h constanta lui Plank
 $6.6261 \cdot 10^{-34} \text{ W s}^2$
- ▶ c viteza luminii **in vid**
 $2.998 \cdot 10^8 \text{ m/s}$
- ▶ e sarcina electronului
 $1.6 \cdot 10^{-19} \text{ C}$
- ▶ benzi energetice: λ_0 , $\Delta\lambda$

Materiale

- ▶ Lungimi de unda mici (spectru vizibil – 1 000nm)
 - GaP (665nm), $\text{GaAs}_y\text{P}_{1-y}$
 - **GaAs** (900nm), $\text{Ga}_{1-x}\text{Al}_x\text{As}$ (AlAs – 550nm)
- ▶ Lungimi de unda mari (1 000÷1 700nm)
 - **InP** (920nm), $\text{In}_x\text{Ga}_{1-x}\text{As}_y\text{P}_{1-y}$
 - x,y concentratii relative in aliaj a materialelor corespunzatoare
 - x,y alese din considerente privind
 - lungimea de unda
 - spatierea atomilor
- ▶ Ultraviolet – Albastru: **GaN**, GaInN

LED cu heterojunțiuni – preview

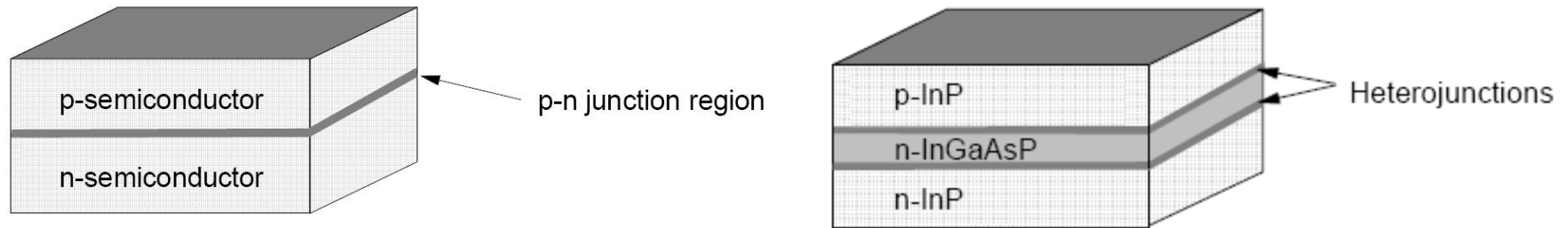

- ▶ **Orice** jonctiune p–n emite lumina
- ▶ O jonctiune p–n obisnuita este foarte subtire
 - volumul in care apar recombinari este foarte mic
 - eficienta luminoasa, redusa
- ▶ lumina este emisa in toate directiile
 - cantitatea de lumina utilizabila (intr–o anumita directie) este redusa

Detalii constructive – 2

- ▶ Spatierea atomilor in diferitele straturi trebuie sa fie egala (toleranta 0.1%) pentru a nu se introduce defecte mecanice la jonctiune
 - limitare a aliajelor utilizabile
 - aparitia defectelor
 - creste ineficienta (recombinari neradiative)
 - scade durata de viata a dispozitivului

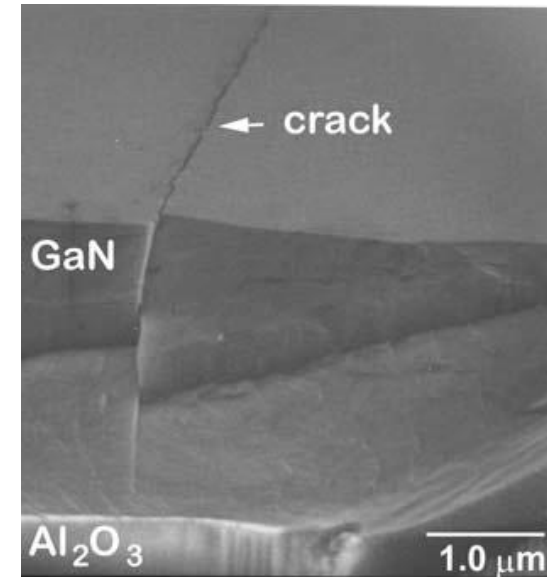

Dependența benzii interzise de constanta rețelei

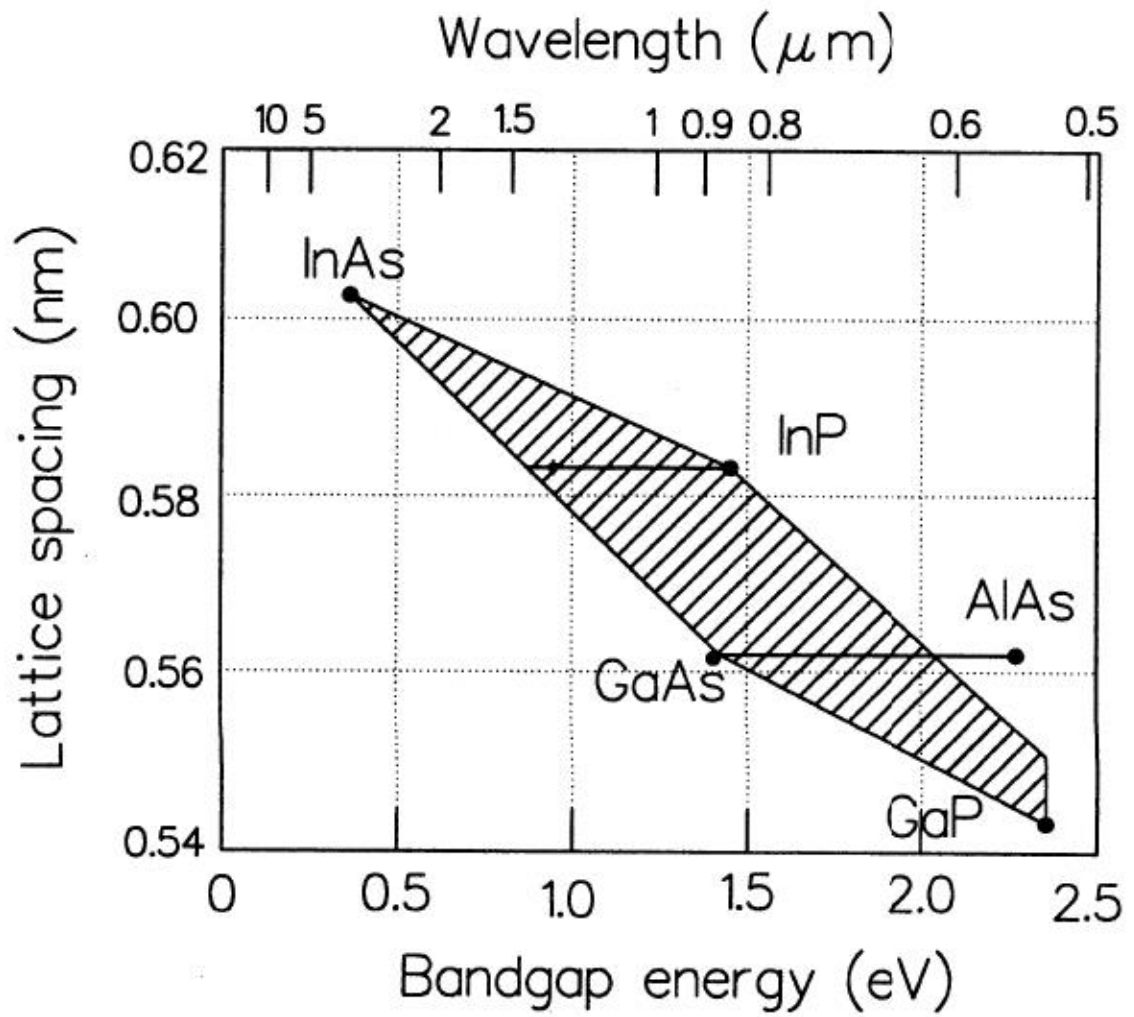
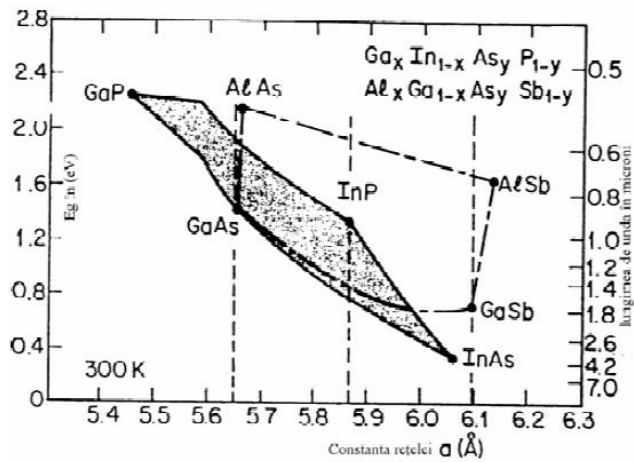

Materiale

- ▶ Lungimi de unda mici
 - $\text{Ga}_{1-x}\text{Al}_x\text{As}$
 - substrat GaAs
 - limitare pentru tranzitie directa, $x < 0.45$
 - E_g (in eV)

$$E_g = 1.424 + 1.247 \cdot x, \quad x < 0.45$$

$$E_g = 1.9 + 0.125 \cdot x + 0.143 \cdot x^2, \quad x > 0.45$$

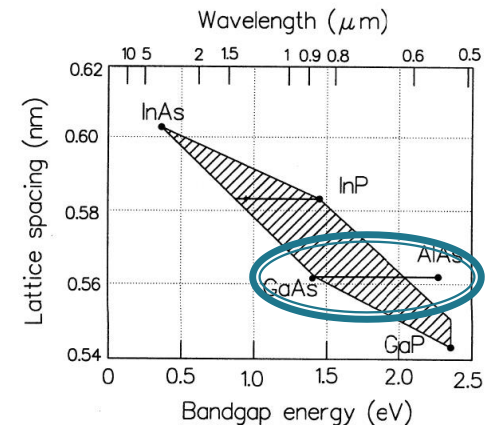
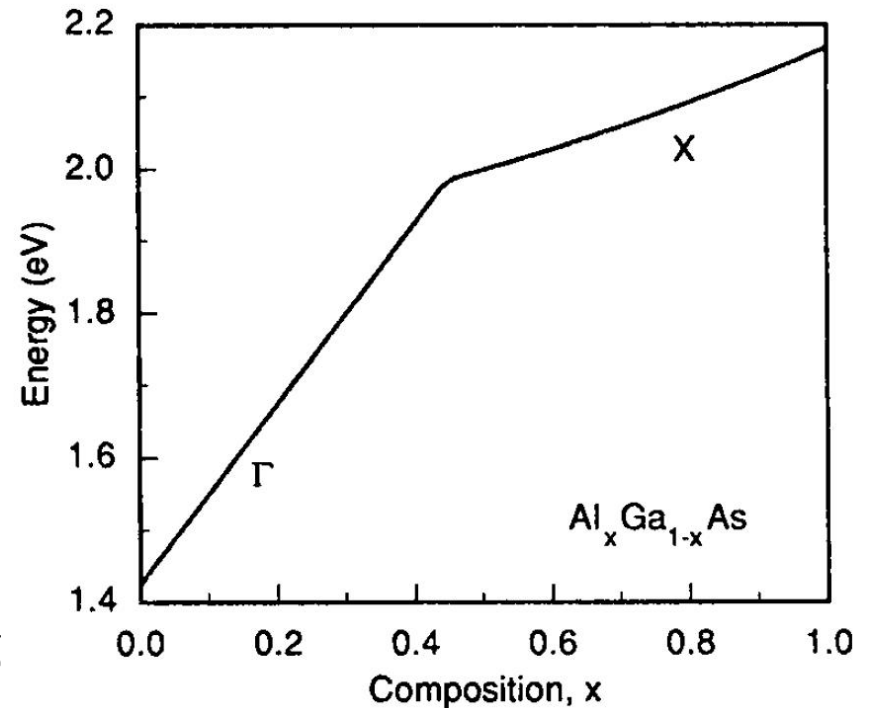

Materiale

- ▶ Lungimi de unda mari
 - $\text{In}_x\text{Ga}_{1-x}\text{As}_y\text{P}_{1-y}$
 - Tipic substratul este InP
 - Spatierea atomilor (lattice spacing) corespunzatoare InP

$$x = \frac{0.4526 \cdot y}{1 - 0.031 \cdot y}$$

- E_g (in eV)

$$E_g = 1.35 - 0.72 \cdot y + 0.12 \cdot y^2$$

- Exemplu: 1300nm se obtine cu $y=0.611$ si $x=0.282$,

- $\text{In}_{0.282}\text{Ga}_{0.718}\text{As}_{0.611}\text{P}_{0.389}$

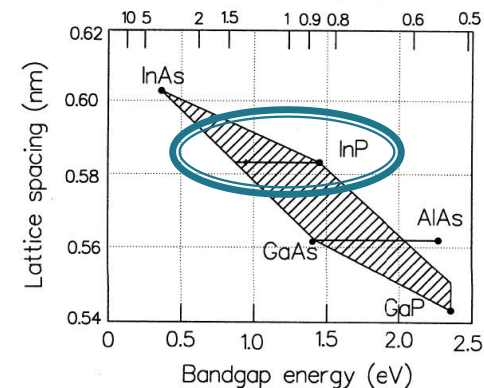
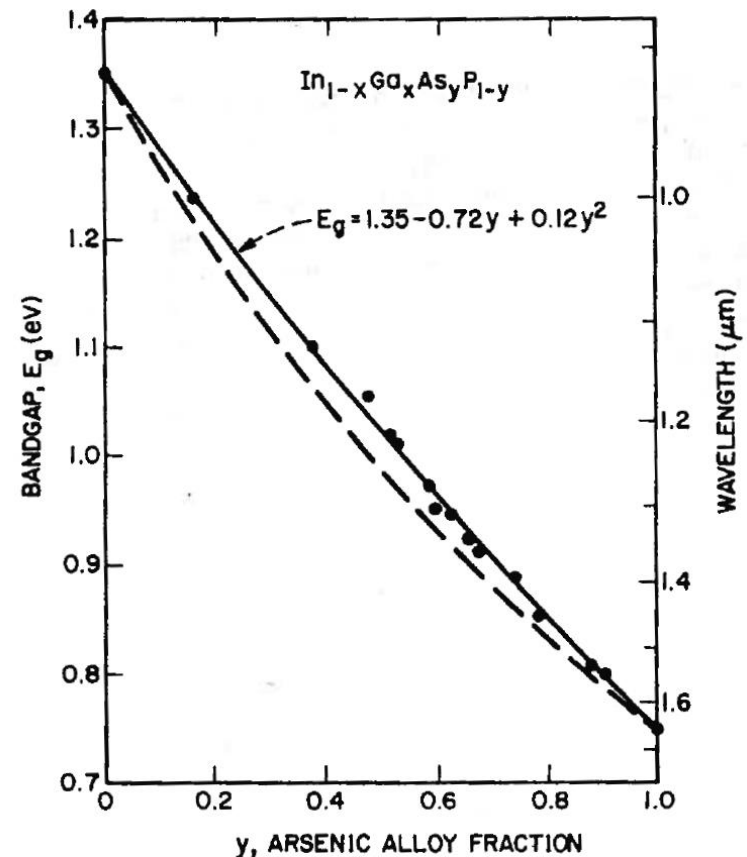

LED cu heterojunțiuni – principiu

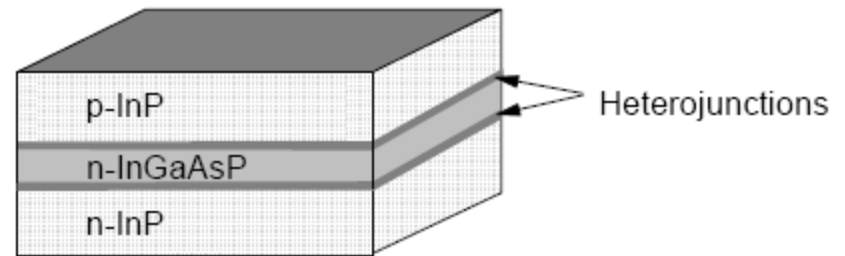
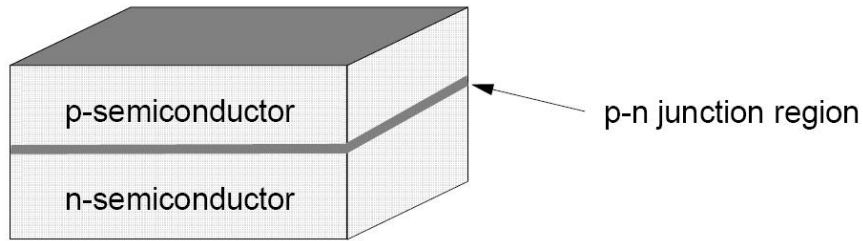

- ▶ Structura de nivele energetice permite capturarea purtătorilor între cele două heterojunțiuni

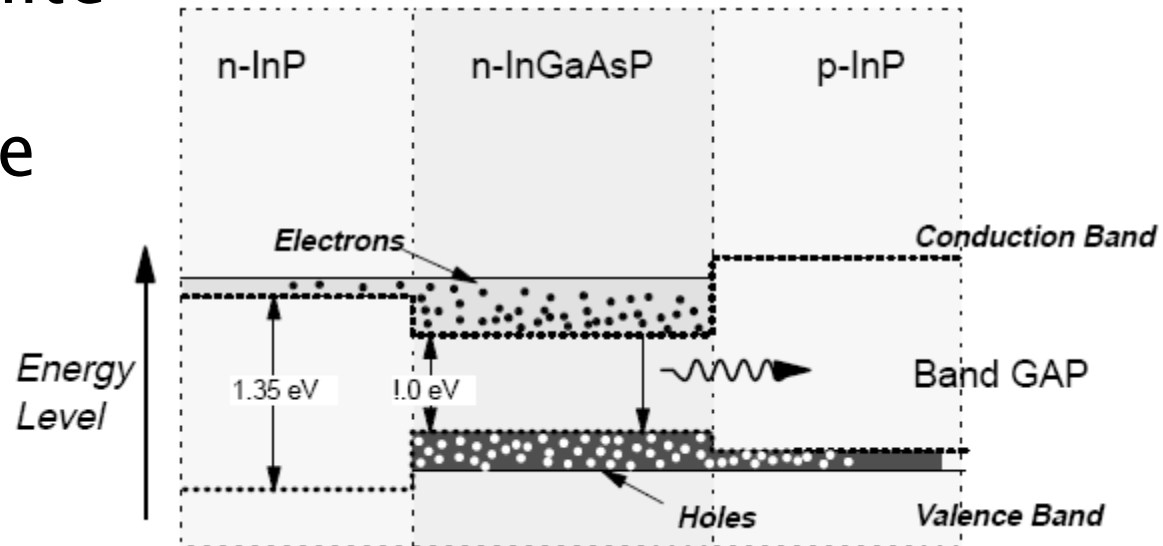

Emisia luminii spre exterior

- ▶ Indici de refractie ridicati
 - InP $n=3.4$
 - GaAs $n=3.6$
- ▶ Doua probleme generate
 - pierderi prin reflexie ridicate
 - unghi critic de numai $\sim 15^\circ$

Emisia luminii spre exterior

▶ Solutii

- utilizarea unui material intermediar pentru adaptarea indicelui de refractie (rasina epoxidica)
- adaptarea formei de iesire din dispozitiv – forma de dom
 - eficienta de cuplaj

interfata plana
semiconductor
aer $\frac{1}{n \cdot (n+1)^2}$

dom $\frac{2n}{(n+1)^2}$

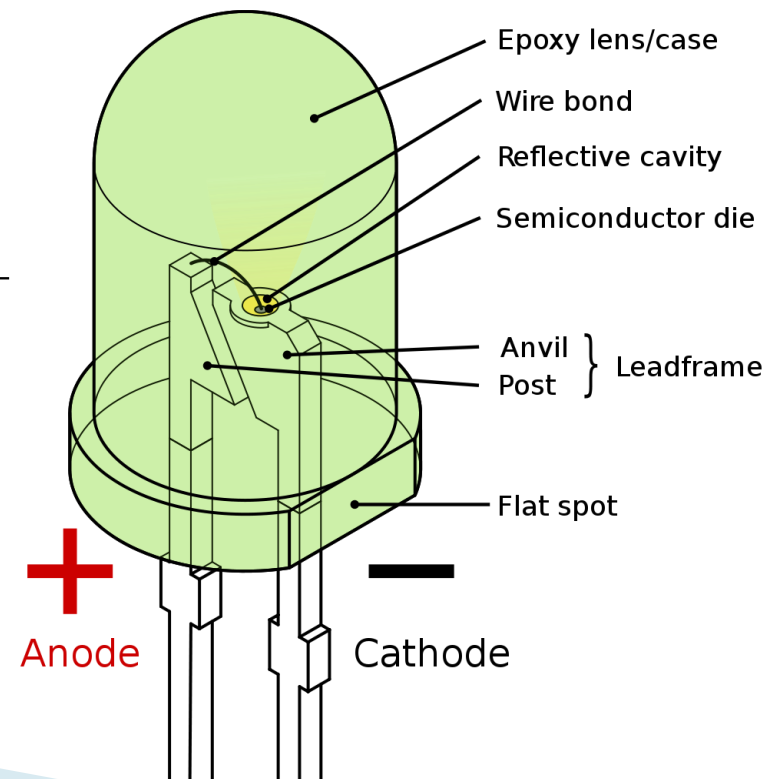

Cuplarea luminii în fibră

(a) Grin Lens

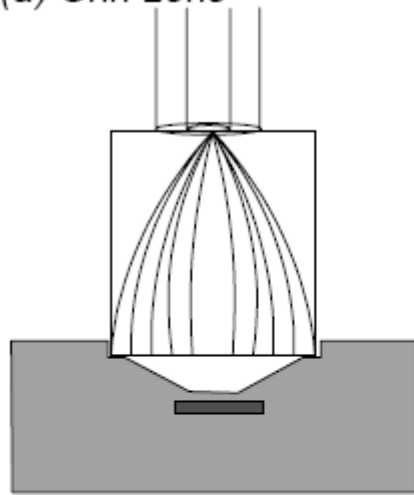

(b) Ball Lens

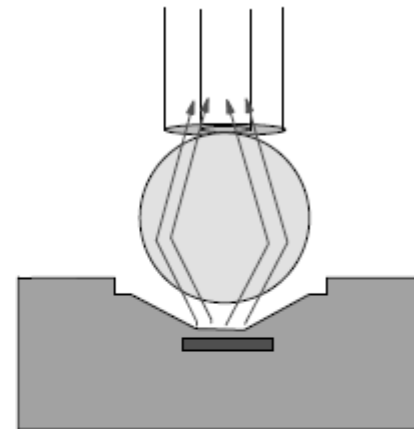

(c) Direct coupling

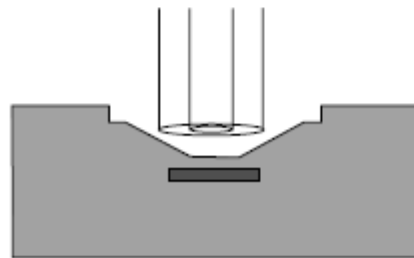

(d) Lensed fibre end

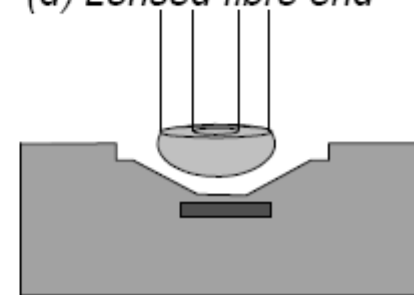

numai pentru fibre multimod cu salt de indice

Directivitatea radiatiei exterioare

- ▶ Sursa lambertiana

$$P(\theta) = P_0 \cdot \cos \theta$$

- ▶ Aproximatie Lambertiana pentru surse cu directivitate crescuta

$$P(\theta) = P_0 \cdot \cos^n \theta$$

- ▶ Surse cu emisie asimetrica

$$P(\theta) = \frac{P_0}{\frac{\sin^2 \phi}{\cos^T \theta} + \frac{\cos^2 \phi}{\cos^L \theta}}$$

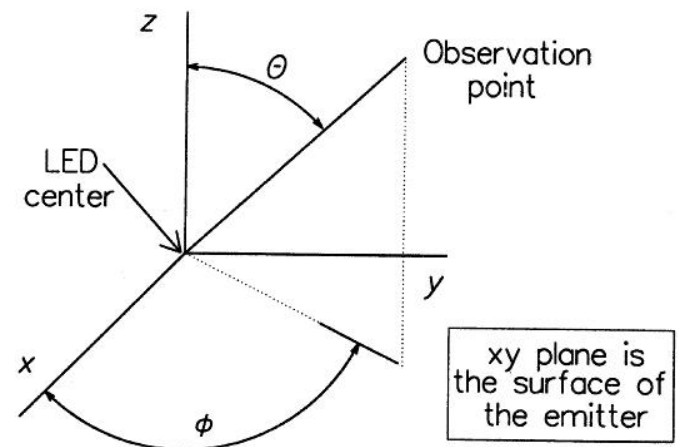
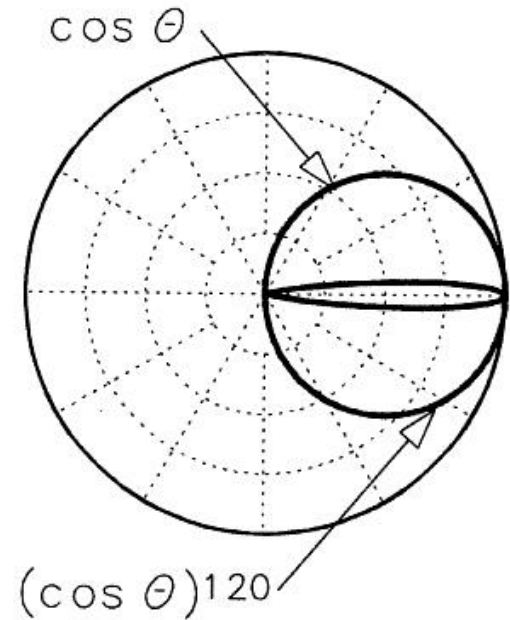

Directivitatea radiatiei exterioare

▶ SLED

- radiatia este emisa cu simetrie circulara, in interiorul unui con cu unghi la varf tipic de 60°
- Viewing Half Angle $\sim 10 \div 15^\circ$

▶ ELED

- radiatia emisa nesimetric in forma de con eliptic
 - perpendicular pe jonctiune $\sim 60^\circ$
 - paralel cu jonctiunea $\sim 30^\circ$

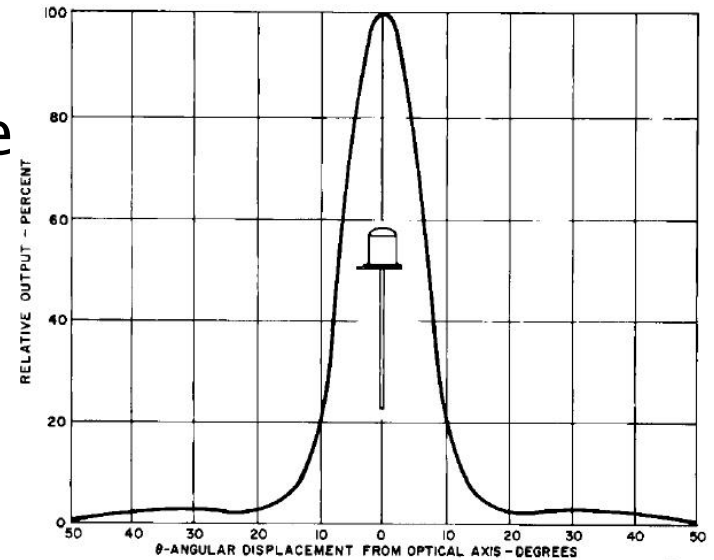
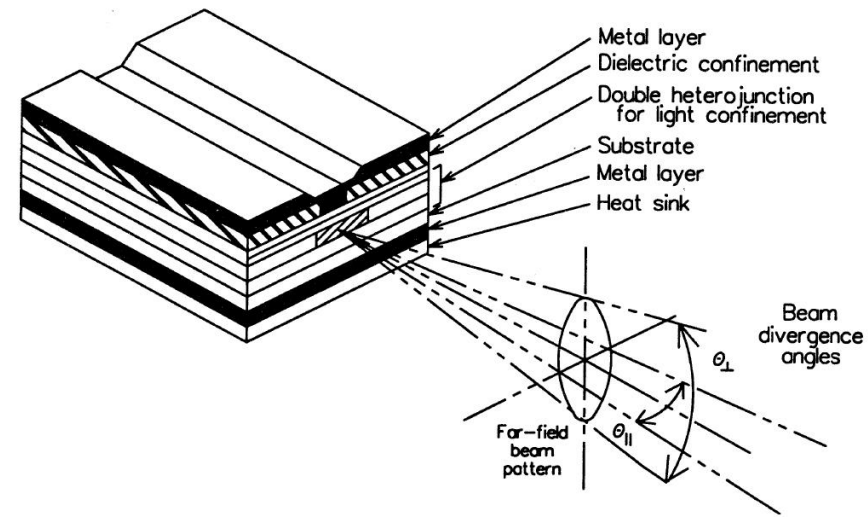
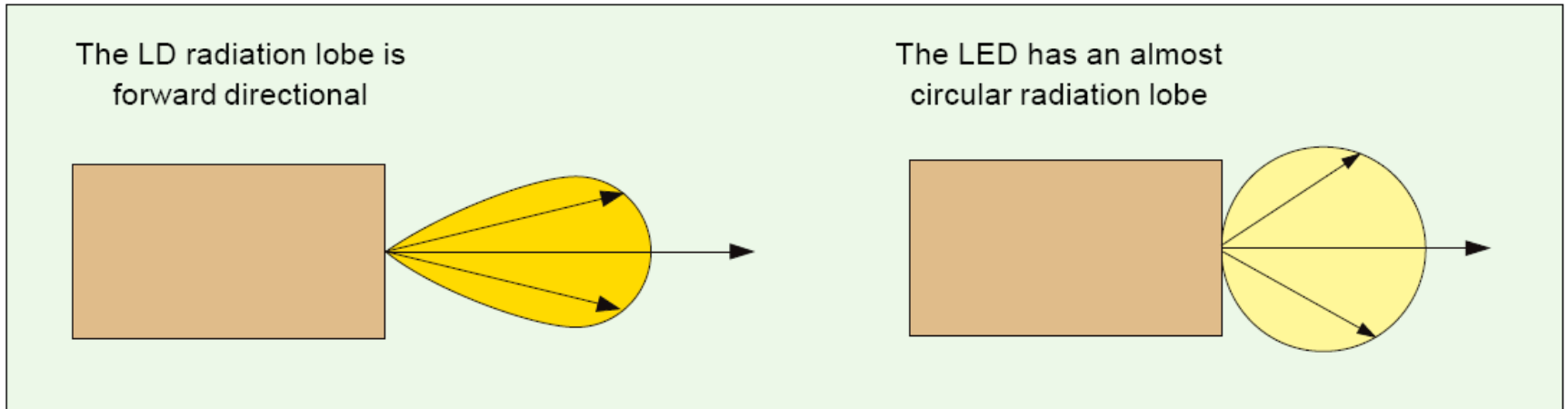

Fig. 5. Typical Radiation Pattern

ST1054



Profil de radiație a emițătorilor optici



- ▶ Apertura numerică poate varia de la 0.9 pentru un LED de unghi foarte larg, la 0.2 pentru un LED prevăzut cu lentilă.
- ▶ Chiar și pentru un NA de 0.2, aria emisivă este mare comparativ cu a unui laser. În consecință, densitatea de putere emisă este mică astfel încât se reduce drastic puterea care poate fi cuplată într-o fibră cu indice gradat, și devine practic imposibilă cuplarea cu o fibră monomod.

Caracteristici putere optică/curent a emițătorilor optici

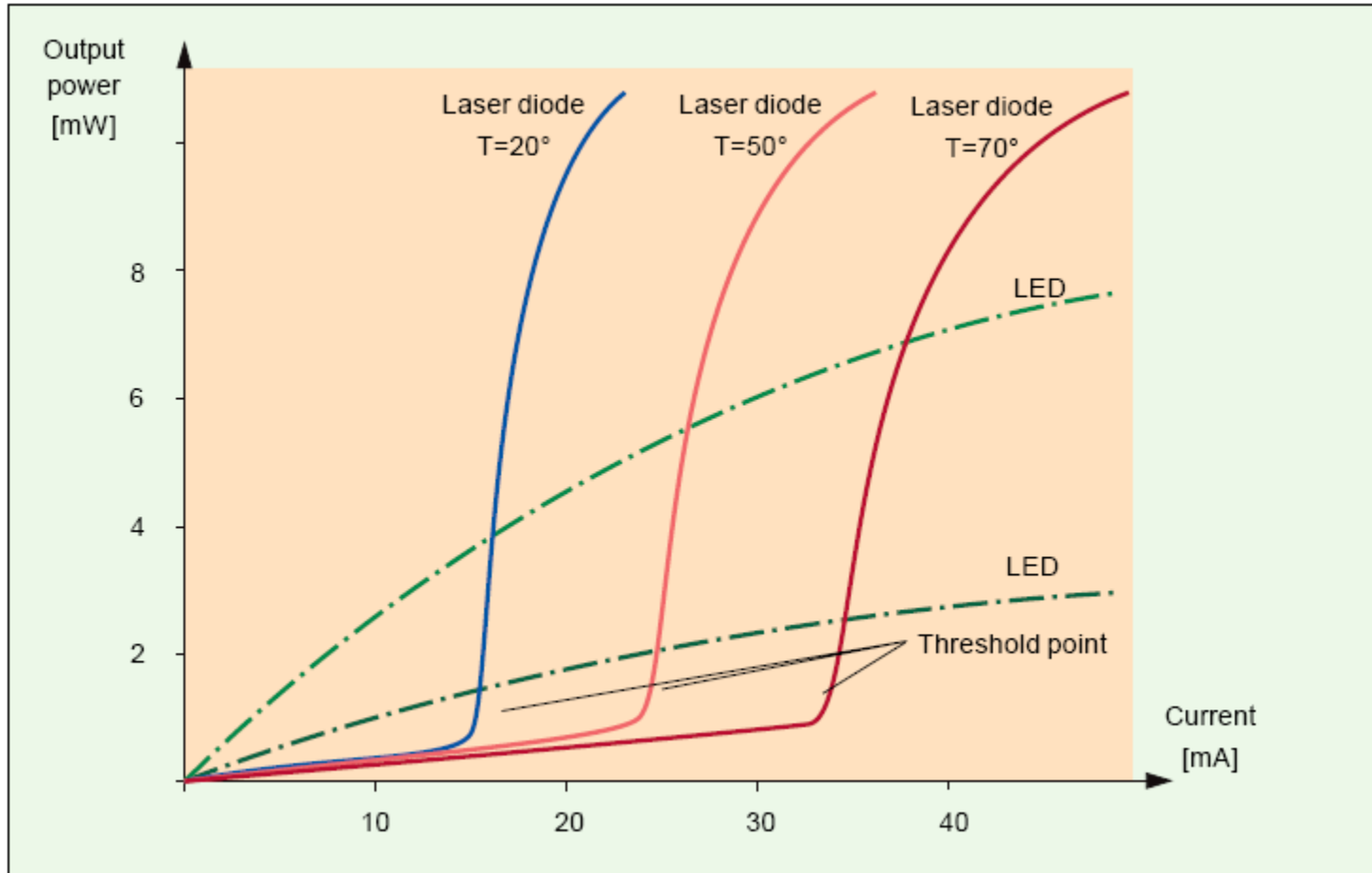

Caracteristica de raspuns a LED-urilor

- ▶ Caracteristica putere optica emisa functie de curentul direct prin LED este liniara la nivele mici ale curentului.
- ▶ Nu exista curent de prag
- ▶ La nivele foarte mari puterea optica se satureaza

- ▶ Responzivitatea

$$r = \frac{P_o}{I} \left[\frac{W}{A} \right]$$

- ▶ Tipic $r = 50 \mu\text{W}/\text{mA}$

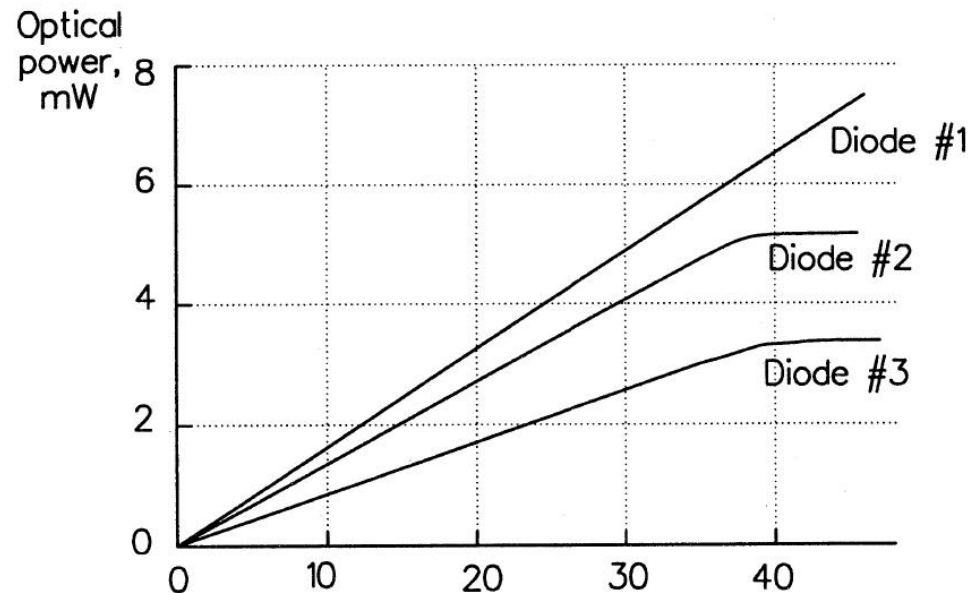

Caracteristica de raspuns a LED-urilor

- ▶ Tipic SLED au eficienta mai buna decat ELED

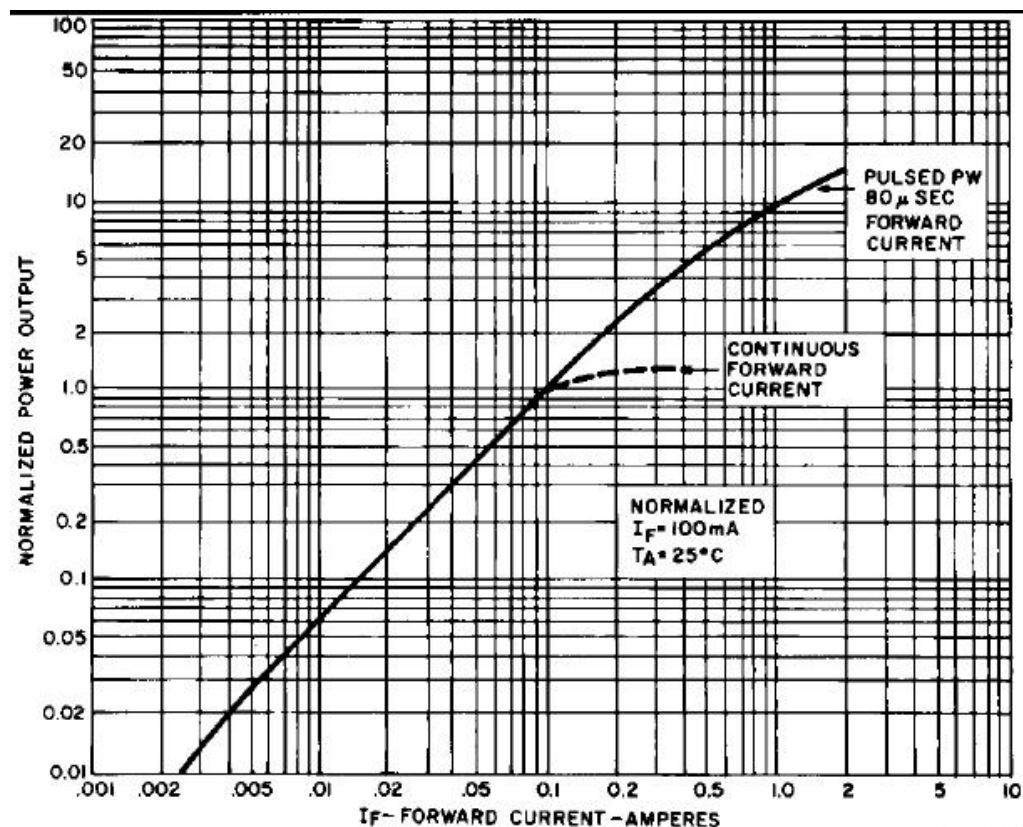
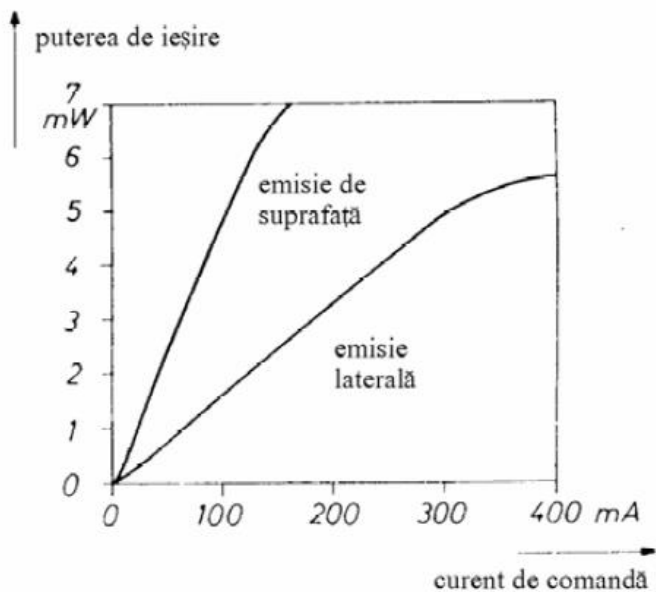

Fig. 1. Power Output vs. Input Current

ST1052

Probleme

- ▶ Un dispozitiv de semnalizare e realizat cu 100 LED-uri care emit lungimea de undă dominantă $\lambda_0 = 590\text{nm}$ sub un con cu unghi la vârf de 5.2° (emisie presupusă **uniformă** în acest con). O diodă are rezponzivitatea de $90\mu\text{W}/\text{mA}$ și este parcursă de un curent de 85mA .
- ▶ a) Estimați intensitatea luminoasă a dispozitivului pe direcție normală.
- ▶ Dacă se consideră emisia **uniformă** în interiorul conului de emisie, fluxul optic energetic este constant în interiorul acestui con și va fi egal cu puterea optică emisă (ambele mărimi reprezintă viteze ale energiei, măsurate în W, cu diferența că puterea optică reprezintă o medie a fluxurilor emise după diferite direcții, valoarea medie a unei mărimi constante fiind egală cu acea mărime)

Aplicatii majore LED

▶ Comunicatii

- Infrarosu (InGaAsP)

▶ Vizibil

- Spectru vizibil (GaAlAs)

▶ Iluminare

- Putere ridicata, lumina alba (GaInN)

Calitatea spectrală a emițătorilor optici

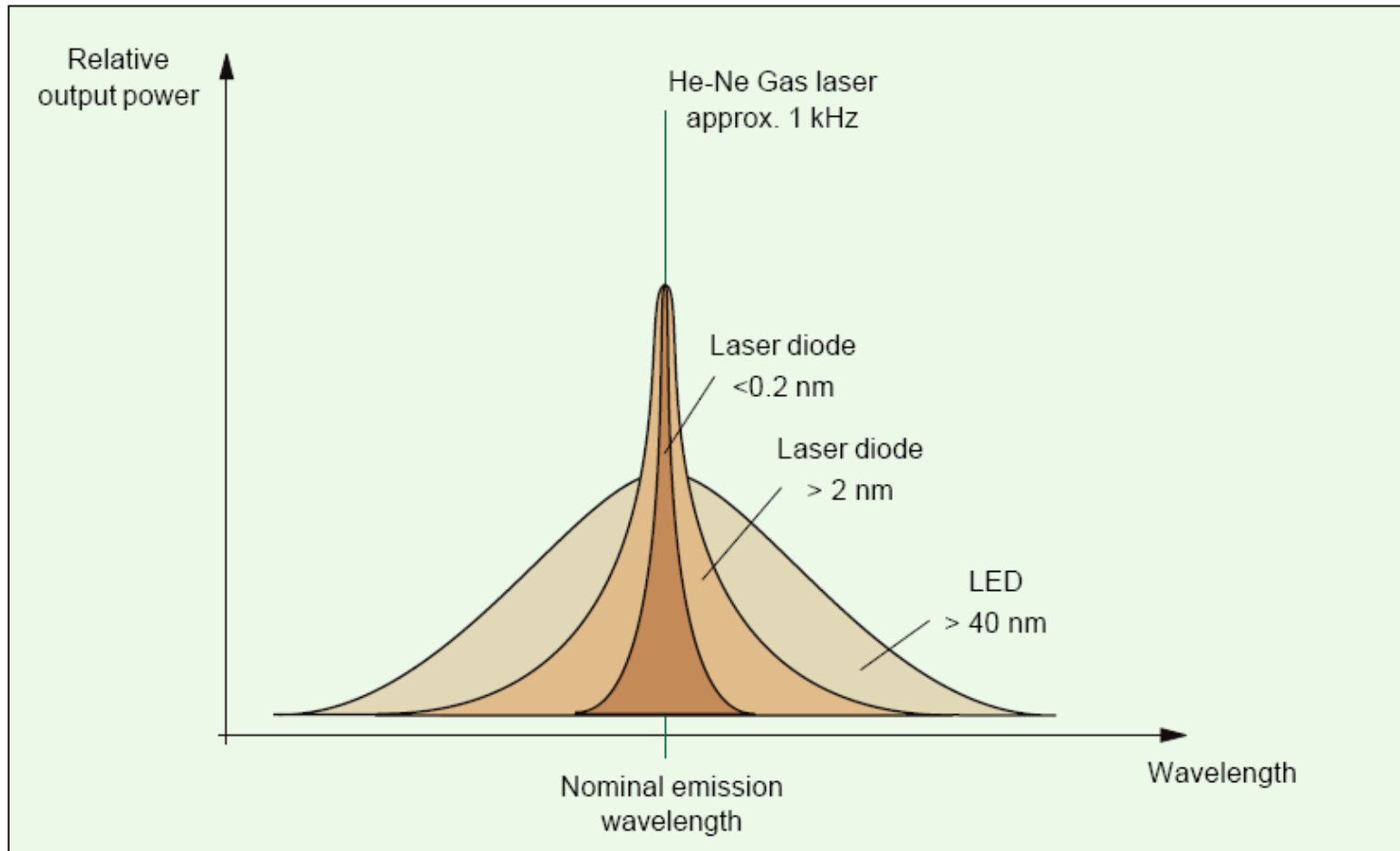

Latimea spectrala a LED-urilor

- ▶ Aproximativ $\Delta\lambda \approx 0.05\lambda$
- ▶ Relatie empirica $\Delta\lambda[\mu m] \approx 1.45\lambda^2[\mu m] \cdot (kT)[eV]$
- ▶ Tipic
 - GaAlAs – 20–40 nm
 - InGaAsP
 - SLED – 100 nm
 - ELED – 60–80 nm
 - GaInN – 30–40 nm (10%)

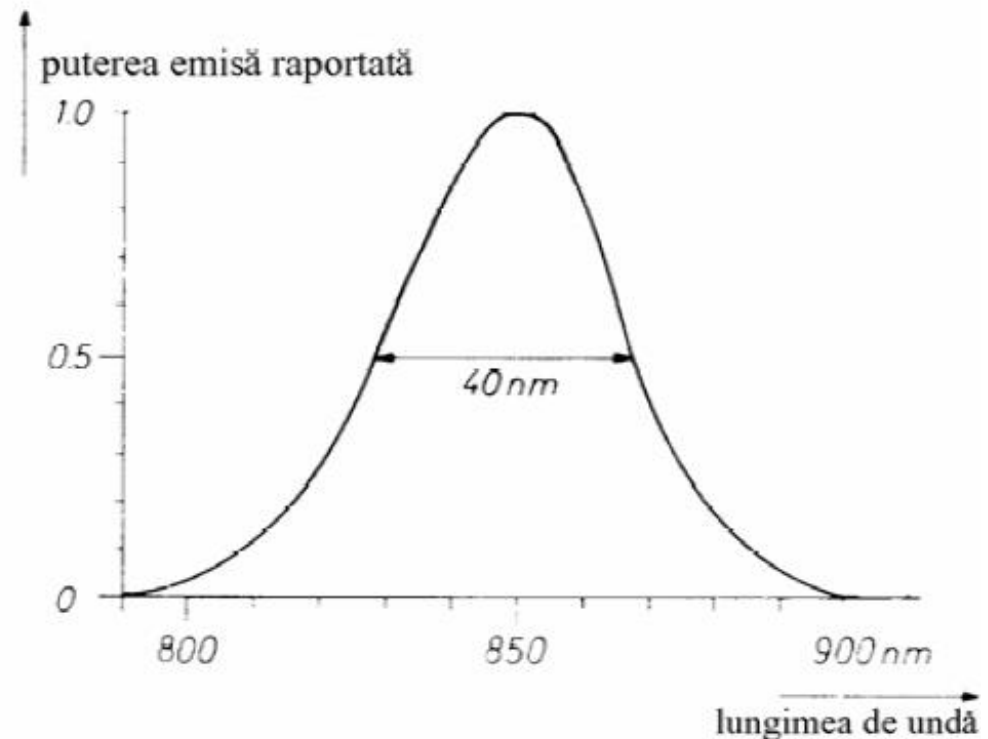

Comportare dinamica a LED

- ▶ Puterea de iesire la modulatia cu un semnal sinusoidal cu ω

$$P_{out} = \frac{P_o}{1 + \omega^2 \tau_{lf}^2}$$

- Puterea electrica variaza proportional cu patrutul curentului
- Puterea optica variaza proportional cu curentul
- ▶ Banda la 3 dB electrica

$$\frac{P_{out}^2}{P_o^2} = \frac{1}{2}$$

$$f_{3dB-el} = \frac{1}{2 \cdot \pi \cdot \tau_{lf}}$$

- Banda la 3 dB optic

$$\frac{P_{out}}{P_o} = \frac{1}{2}$$

Comportare dinamica a LED

- ▶ Cand curentul care trece prin dispozitiv e mic timpul de viata al purtatorilor e independent de curent si este dependent liniar de nivelul de dopare in regiunea activa
- ▶ Cand curentul este mare timpul de viata al purtatorilor este proportional cu \sqrt{d} si invers proportional cu \sqrt{J}
- ▶ **Banda poate fi crescuta**
 - Crescand nivelul de dopare
 - Reducand inaltimea zonei active
 - Crescand densitatea de curent

Comportare dinamica a LED

- ▶ In domeniul timp
- ▶ Timpul de crestere (rise time)

$$t_r = 2.20 \cdot \left(\frac{2 \cdot k \cdot T \cdot C_s}{e \cdot I_p} + \tau_{lf} \right)$$

- ▶ Capacitatea asociata sarcinilor in regiunea activa: 350 ÷ 1000pF
- ▶ Produs Putere × Banda

$$P \times \Delta f = \frac{h \cdot c}{2 \cdot \pi \cdot e \cdot \lambda} \cdot \frac{J}{\tau_{lf}}$$

Aplicatii majore LED

- ▶ Comunicatii
 - Infrarosu (InGaAsP)
- ▶ Vizibil
 - Spectru vizibil (GaAlAs)
- ▶ Iluminare
 - Putere ridicata, lumina alba (GaInN)

Aplicatii in spectru vizibil

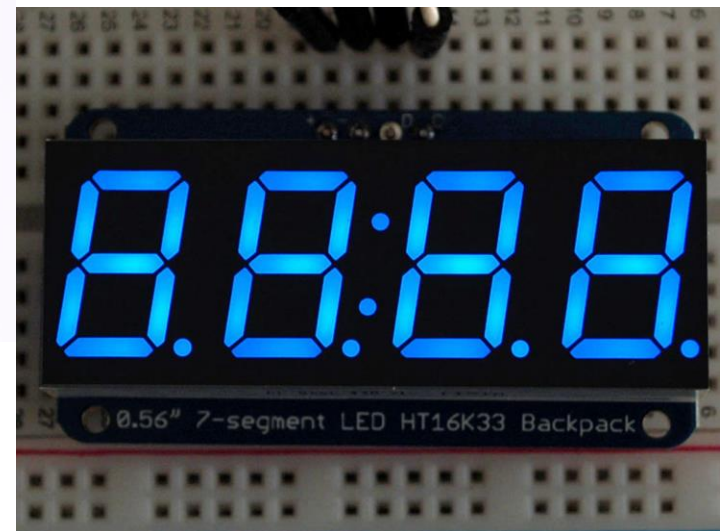
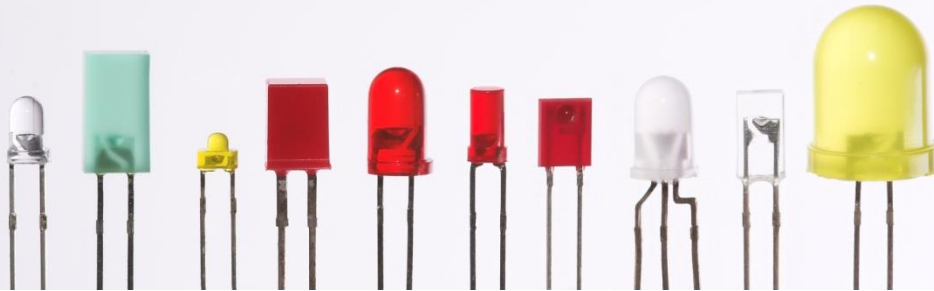
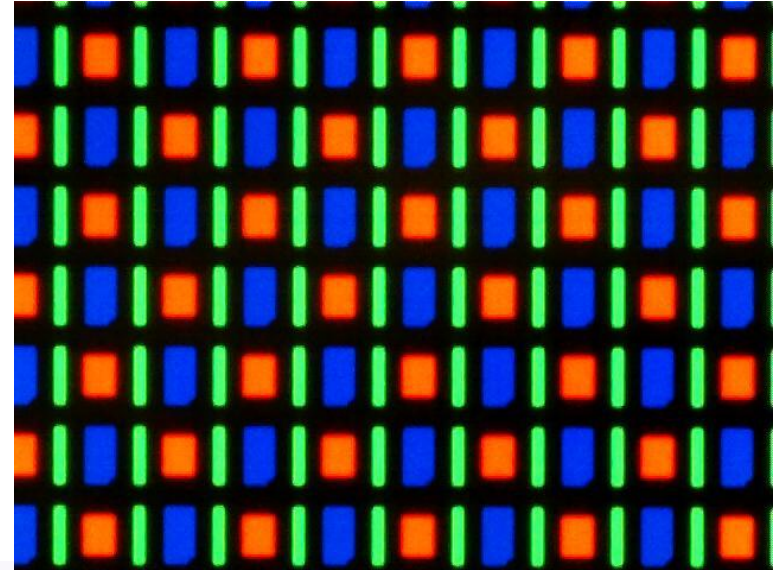

LED albastru

- ▶ bazat pe GaInN
- ▶ dezvoltare tardiva (GaN)

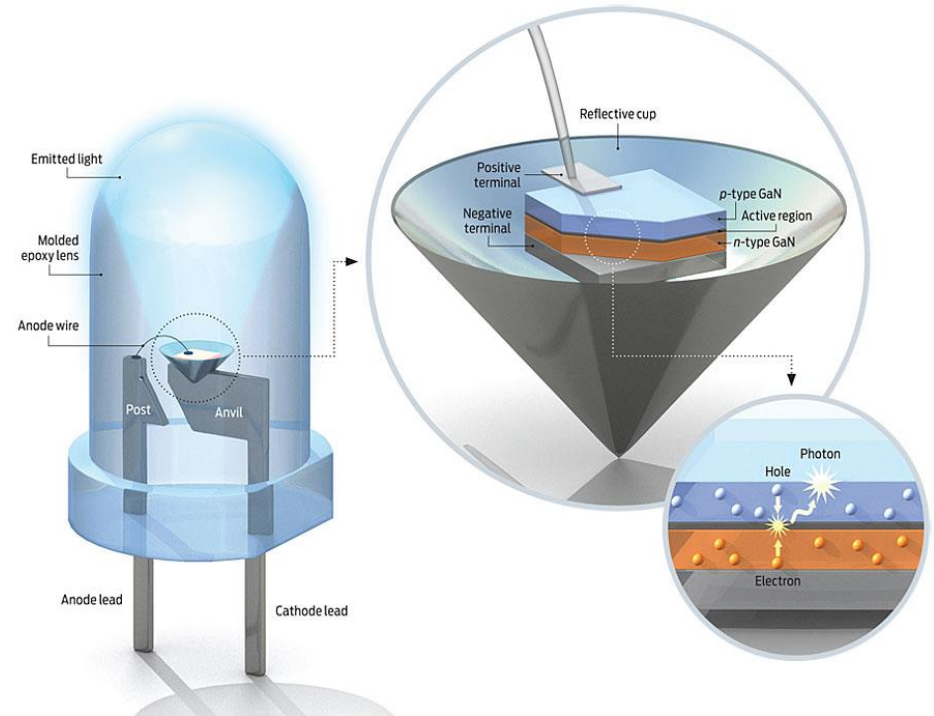
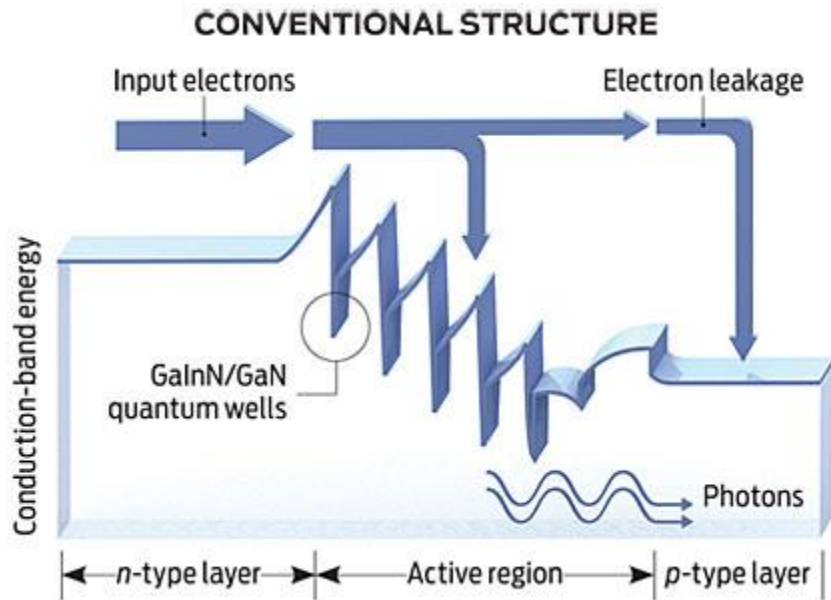

LED albastru

- ▶ realizare: GaInN Quantum Well/GaN

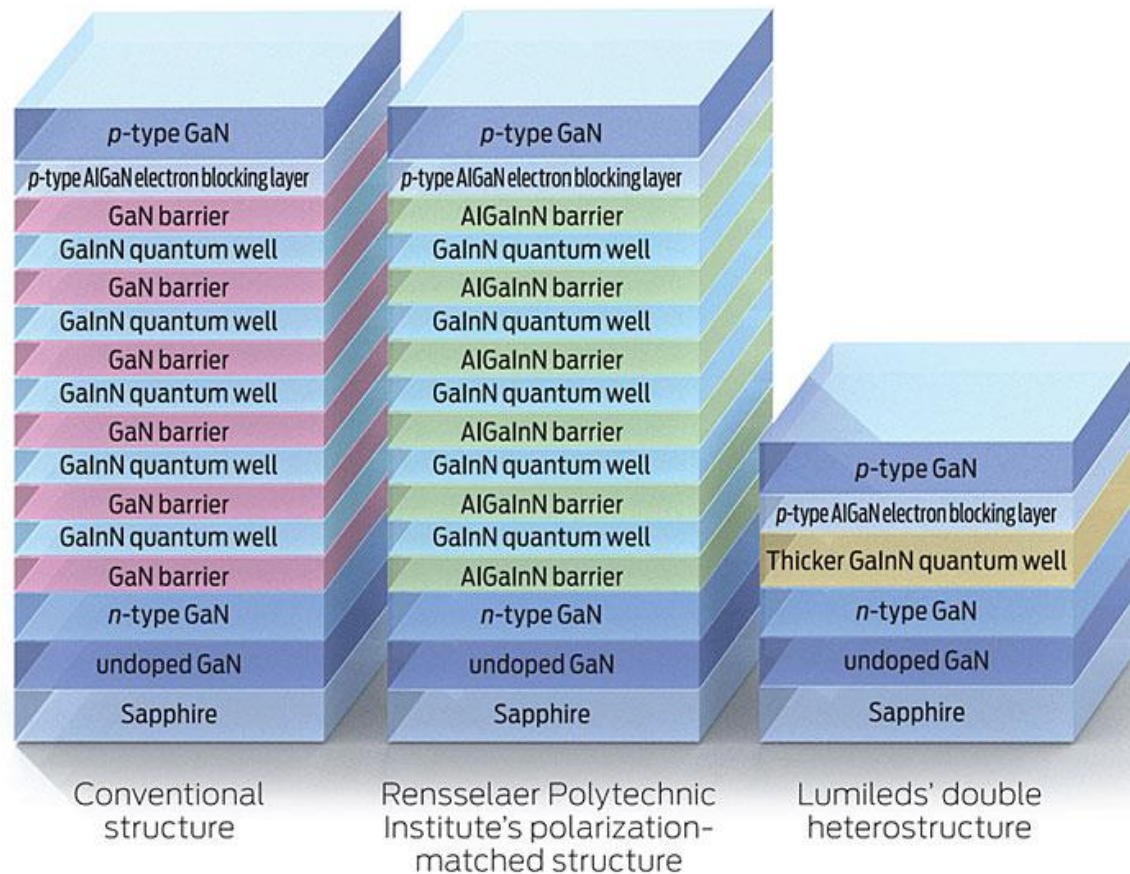

Spectru LED albastru

- ▶ $\Delta\lambda$ relativ la λ mai mare

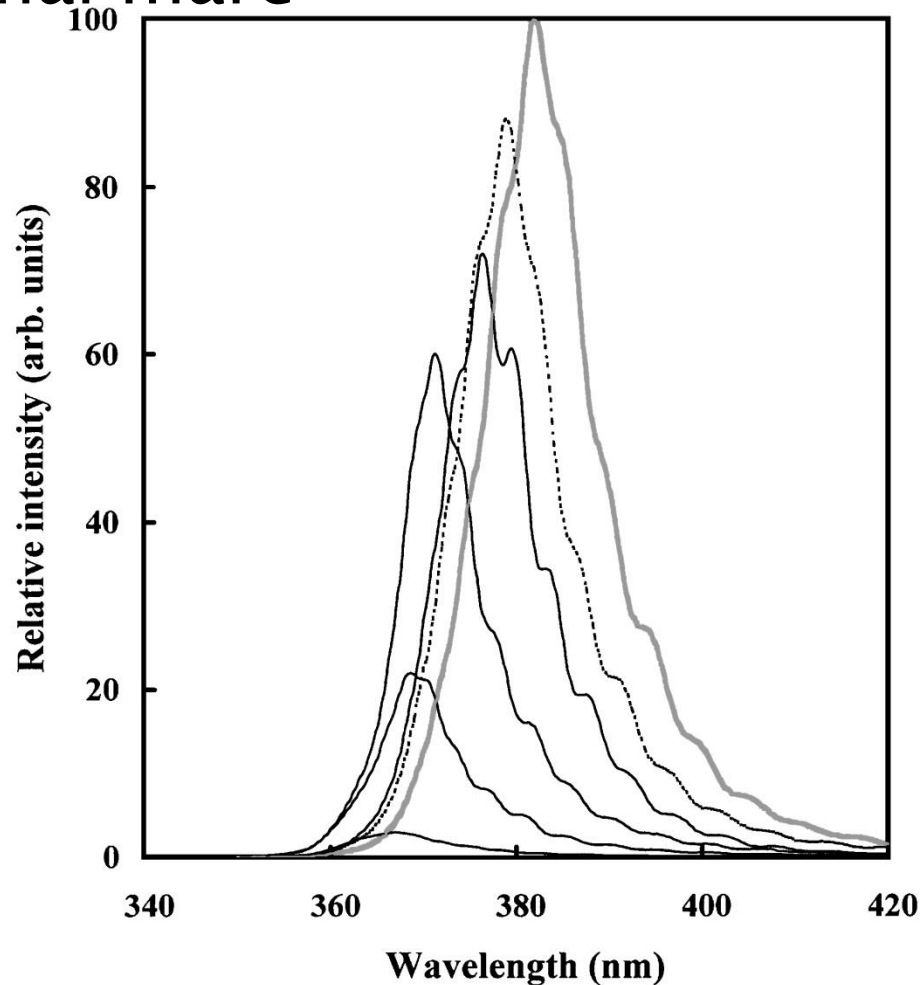

Eficiencia cuantica

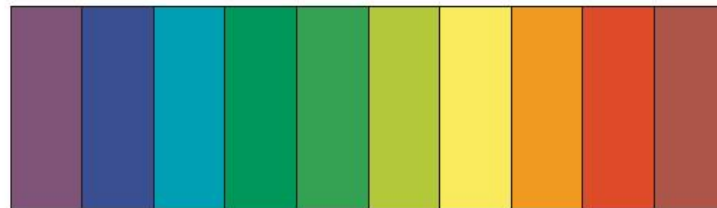
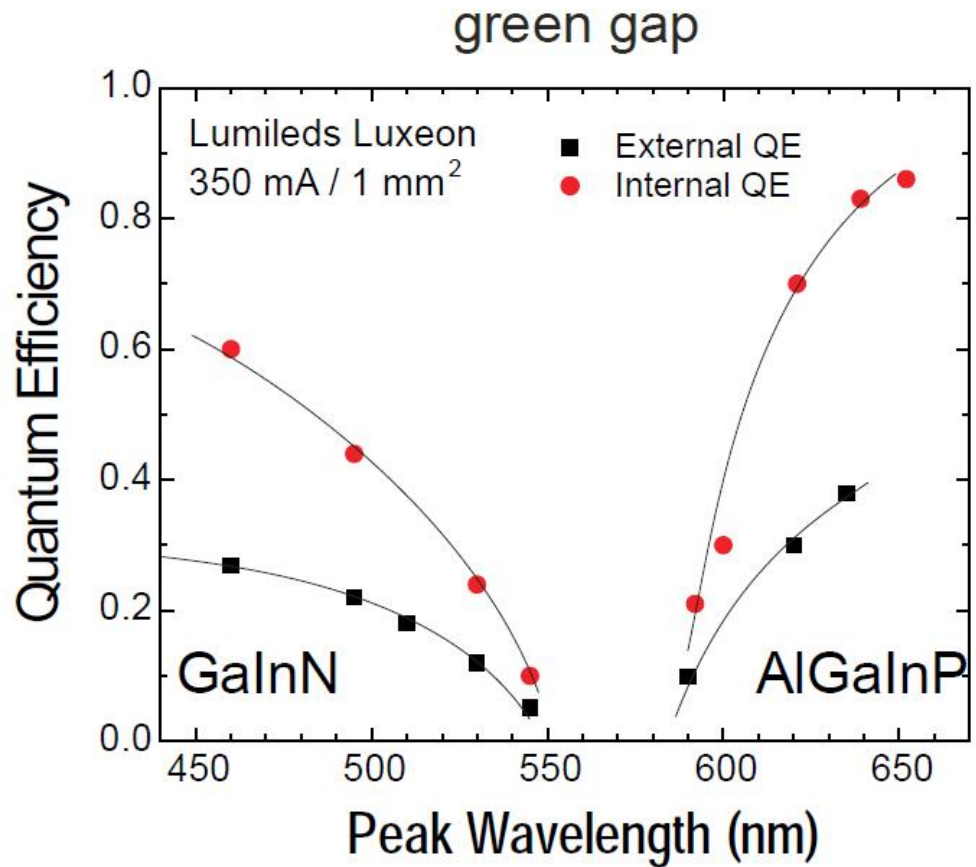

Culori/materiale - 1

Color	Wavelength (nm)	Voltage (V)	Semiconductor Material
Infrared	$\lambda > 760$	$\Delta V < 1.9$	Gallium arsenide (GaAs) Aluminium gallium arsenide (AlGaAs)
Red	$610 < \lambda < 760$	$1.63 < \Delta V < 2.03$	Aluminium gallium arsenide (AlGaAs) Gallium arsenide phosphide (GaAsP) Aluminium gallium indium phosphide (AlGaInP) Gallium(III) phosphide (GaP)
Orange	$590 < \lambda < 610$	$2.03 < \Delta V < 2.10$	Gallium arsenide phosphide (GaAsP) Aluminium gallium indium phosphide (AlGaInP) Gallium(III) phosphide (GaP)
Yellow	$570 < \lambda < 590$	$2.10 < \Delta V < 2.18$	Gallium arsenide phosphide (GaAsP) Aluminium gallium indium phosphide (AlGaInP) Gallium(III) phosphide (GaP)
Green	$500 < \lambda < 570$	$1.9 < \Delta V < 4.0$	Indium gallium nitride (InGaN) / Gallium(III) nitride (GaN) Gallium(III) phosphide (GaP) Aluminium gallium indium phosphide (AlGaInP) Aluminium gallium phosphide (AlGaP)

Culori/materialiale – 2

Color	Wavelength (nm)	Voltage (V)	Semiconductor Material
Blue	$450 < \lambda < 500$	$2.48 < \Delta V < 3.7$	Zinc selenide (ZnSe) Indium gallium nitride (InGaN) Silicon carbide (SiC) as substrate Silicon (Si) as substrate — (under development)
Violet	$400 < \lambda < 450$	$2.76 < \Delta V < 4.0$	Indium gallium nitride (InGaN)
Purple	multiple types	$2.48 < \Delta V < 3.7$	Dual blue/red LEDs, blue with red phosphor, or white with purple plastic
Ultraviolet	$\lambda < 400$	$3.1 < \Delta V < 4.4$	Diamond (235 nm) Boron nitride (215 nm) Aluminium nitride (AlN) (210 nm) Aluminium gallium nitride (AlGaN) Aluminium gallium indium nitride (AlGaInN) — (down to 210 nm)
White	Broad spectrum	$\Delta V = 3.5$	Blue/UV diode with yellow phosphor

Denumiri tipice – LED

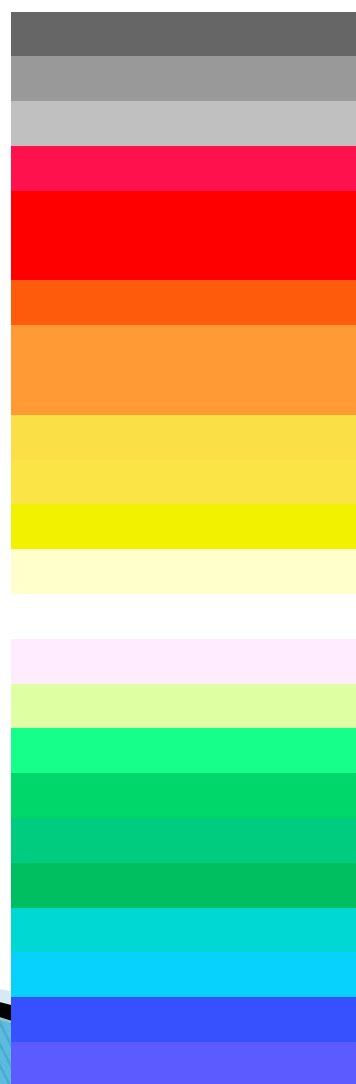

Wavelength (nm)	Color Name
940	Infrared
880	Infrared
850	Infrared
660	Ultra Red
635	High Eff. Red
633	Super Red
620	Super Orange
612	Super Orange
605	Orange
595	Super Yellow
592	Super Pure Yellow
585	Yellow
4500K	"Incandescent" White
6500K	Pale White
8000K	Cool White
574	Super Lime Yellow
570	Super Lime Green
565	High Efficiency Green
560	Super Pure Green
555	Pure Green
525	Aqua Green
505	Blue Green
470	Super Blue
430	Ultra Blue

Aplicatii majore LED

- ▶ Comunicatii
 - Infrarosu (InGaAsP)
- ▶ Vizibil
 - Spectru vizibil (GaAlAs)
- ▶ Illuminare
 - Putere ridicata, lumina alba (GaN)

Premiul Nobel, Fizica, 2014

Physics



The Nobel Prize in Physics 2014

Summary



The Nobel Prize in Physics 2014

Isamu Akasaki
Hiroshi Amano
Shuji Nakamura

Share this



The Nobel Prize in Physics 2014



© Nobel Media AB. Photo: A. Mahmoud

Isamu Akasaki

Prize share: 1/3



© Nobel Media AB. Photo: A. Mahmoud

Hiroshi Amano

Prize share: 1/3



© Nobel Media AB. Photo: A. Mahmoud

Shuji Nakamura

Prize share: 1/3

The Nobel Prize in Physics 2014 was awarded jointly to Isamu Akasaki, Hiroshi Amano and Shuji Nakamura "for the invention of efficient blue light-emitting diodes which has enabled bright and energy-saving white light sources."

To cite this section

MLA style: The Nobel Prize in Physics 2014, NobelPrize.org, Nobel Media AB 2021. Tue, 2 Mar 2021.

Eficiența

- ▶ Bec cu incandescenta
 - 16 lm/W
- ▶ Tub fluorescent
 - 100 lm/W
- ▶ LED
 - curent: 250 lm/W
 - curand: 300 lm/W

Eficienta in timp

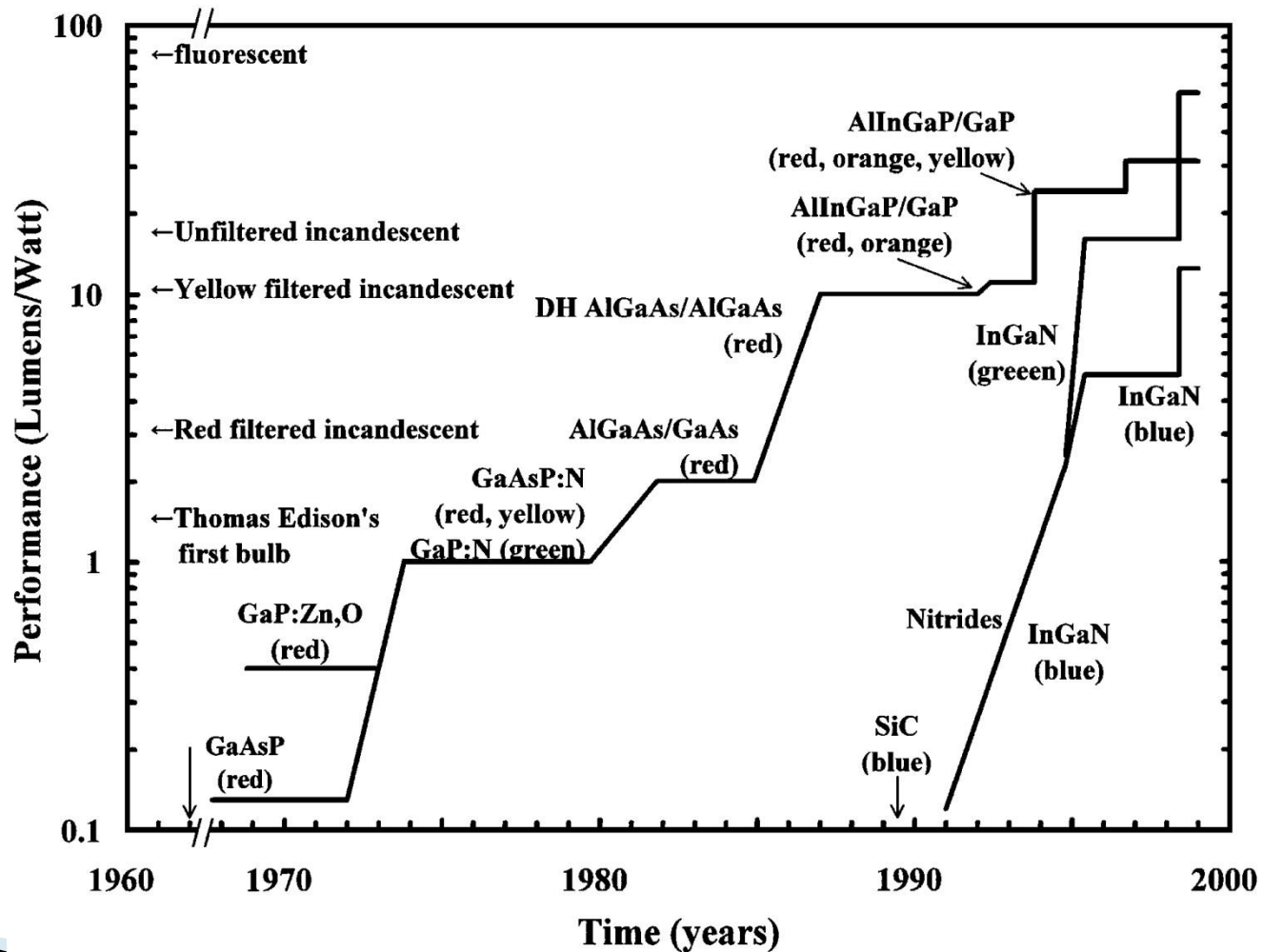

Eficienta in timp

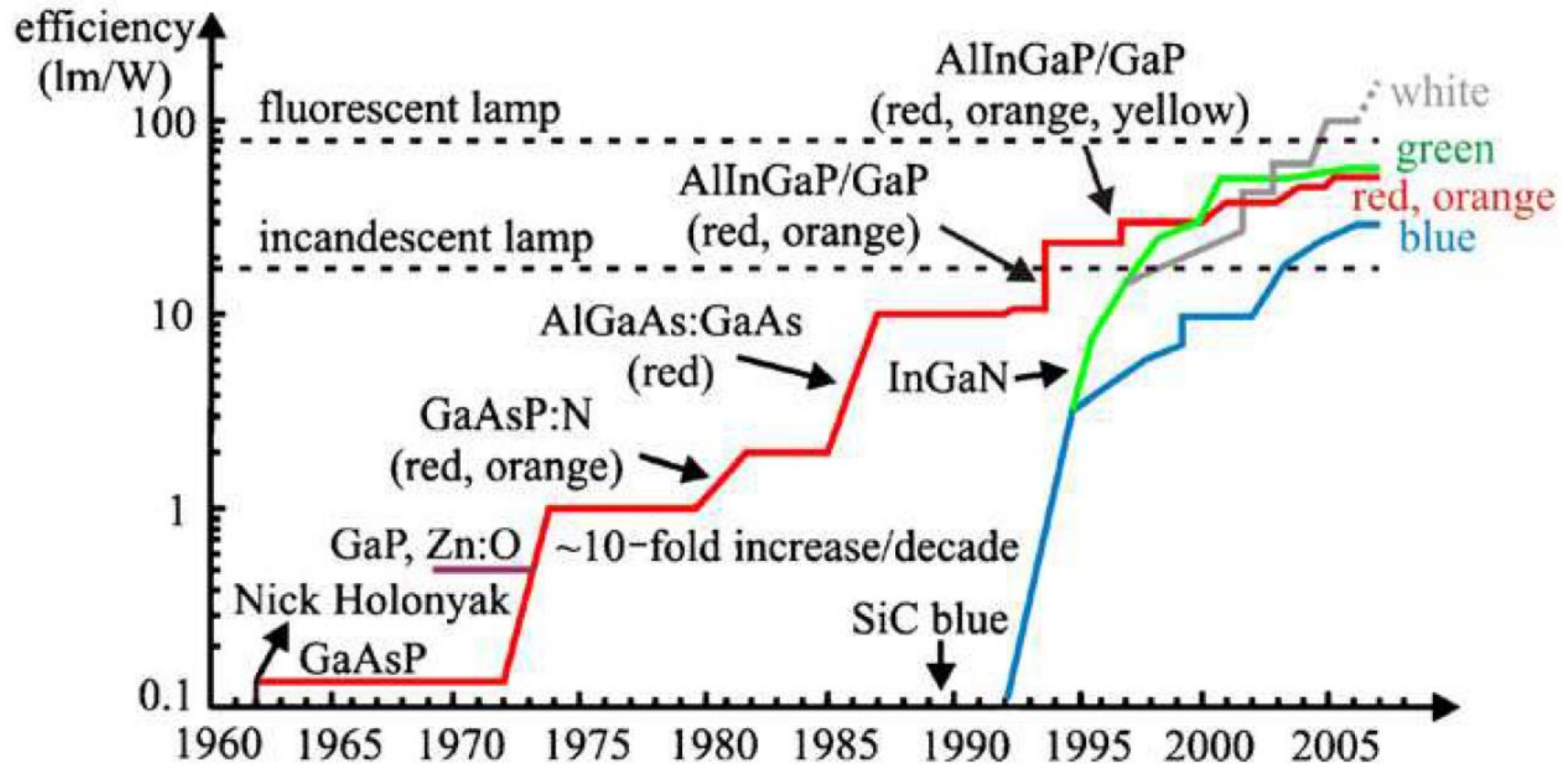

Eficiența în timp

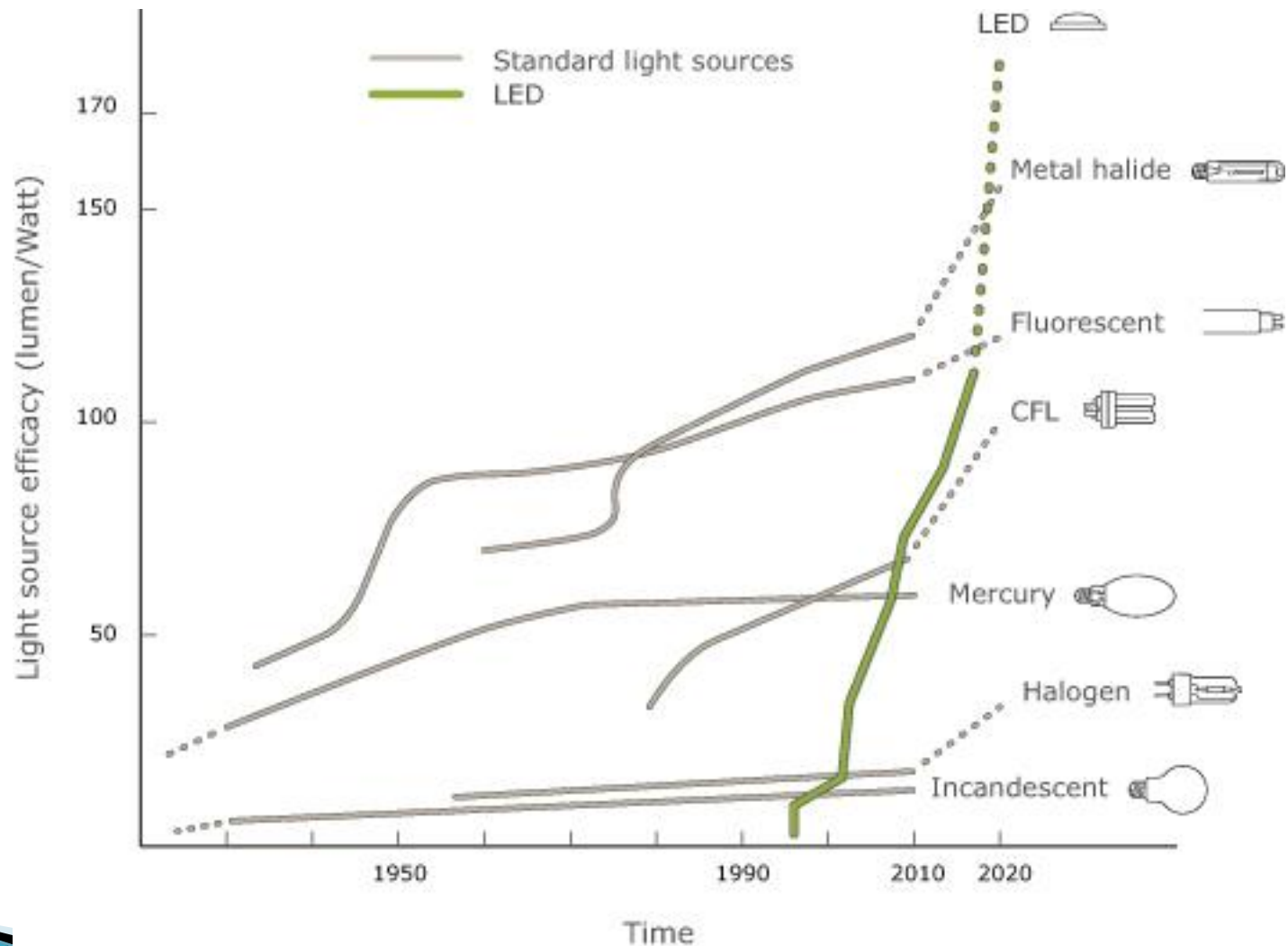

Eficienta in timp

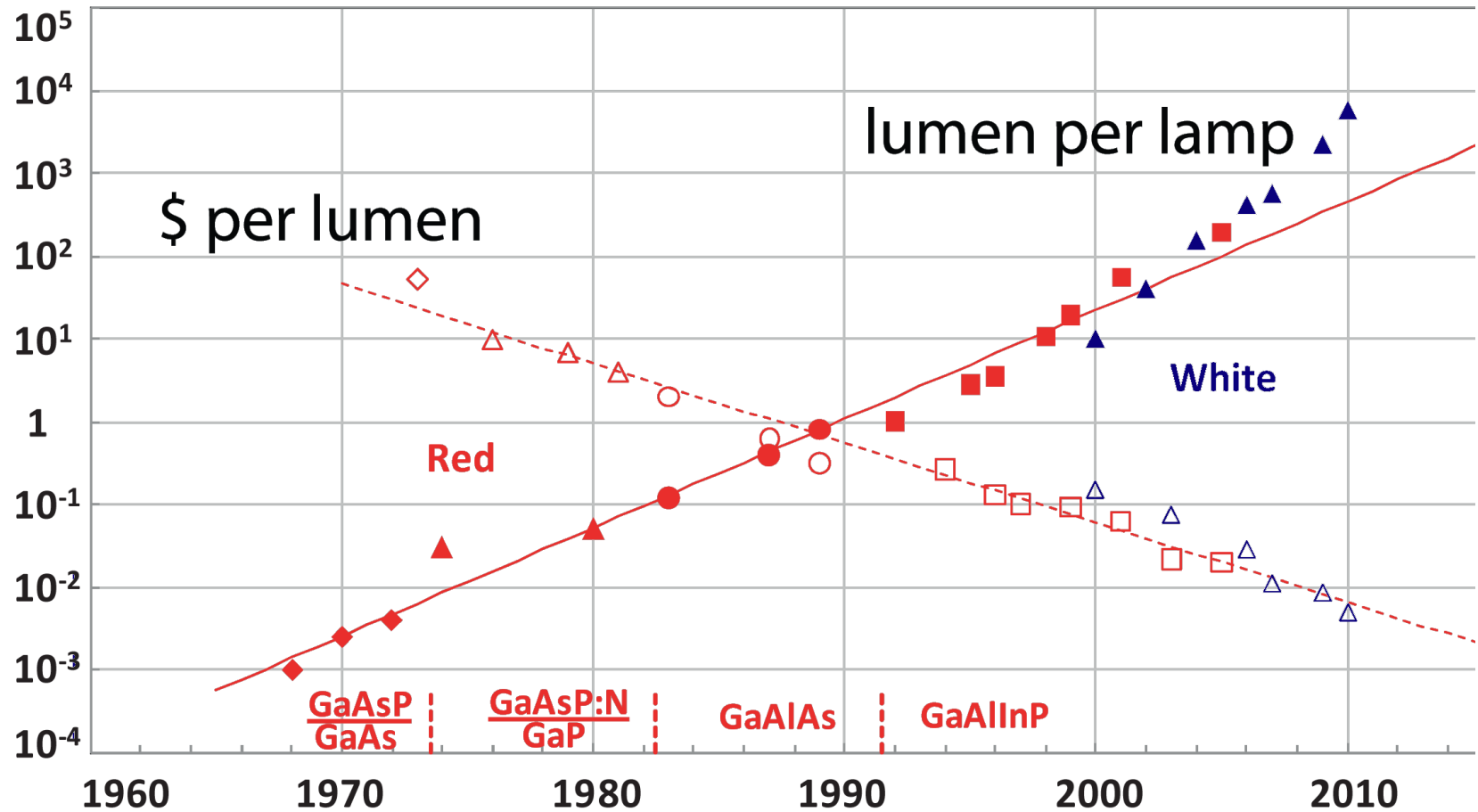

Culoare alba

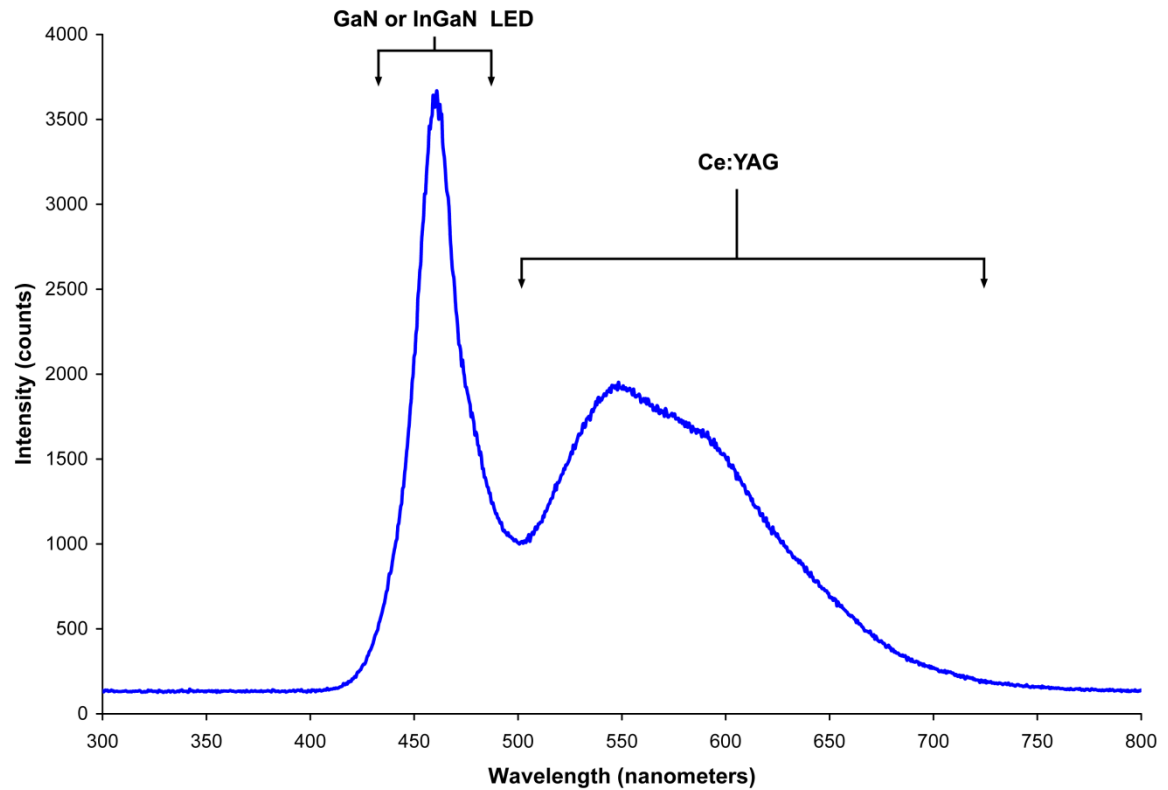
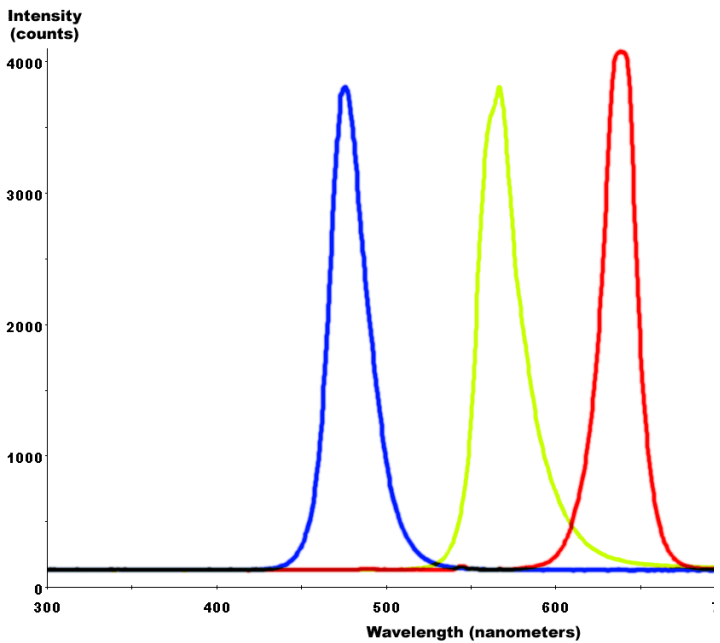

Fosfor activat de LED albastru/UV

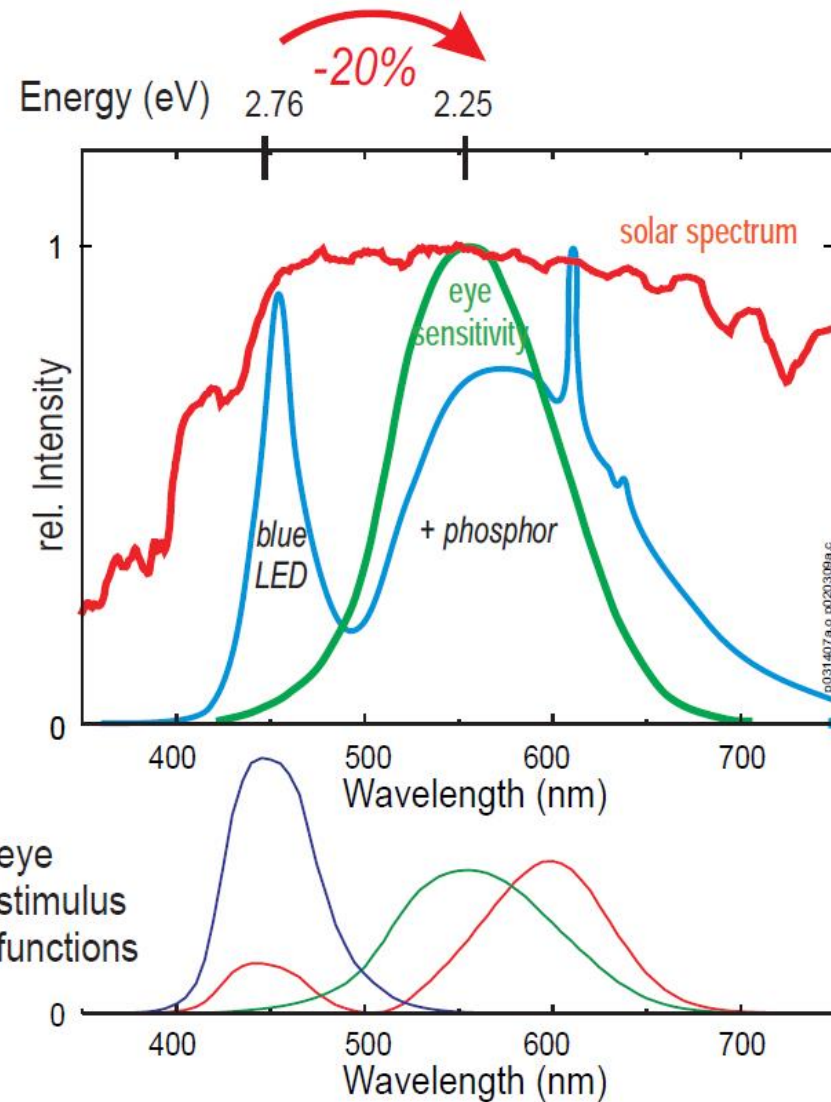

Realizare LED de putere

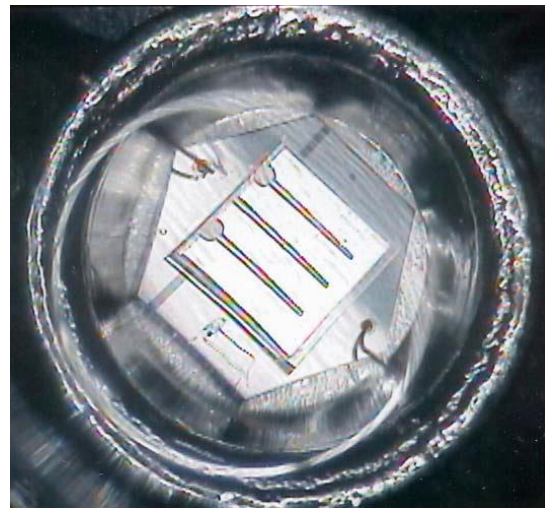
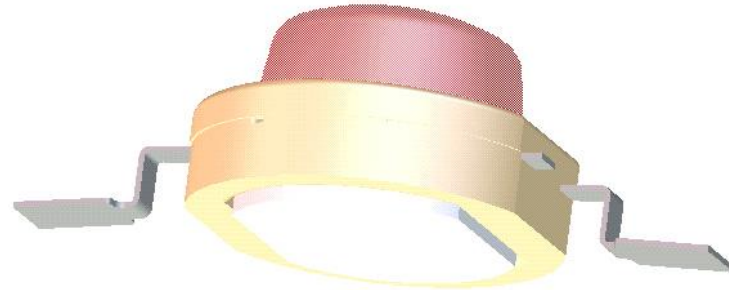
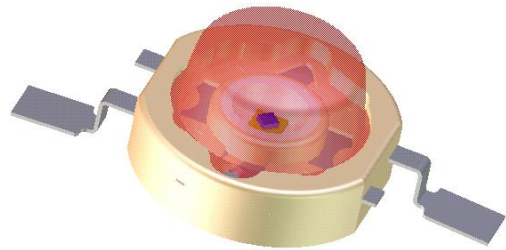

Realizare LED de putere

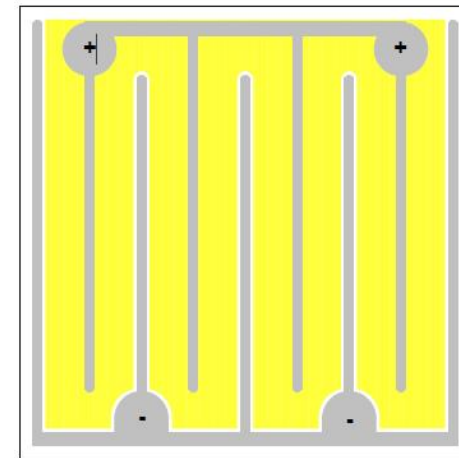
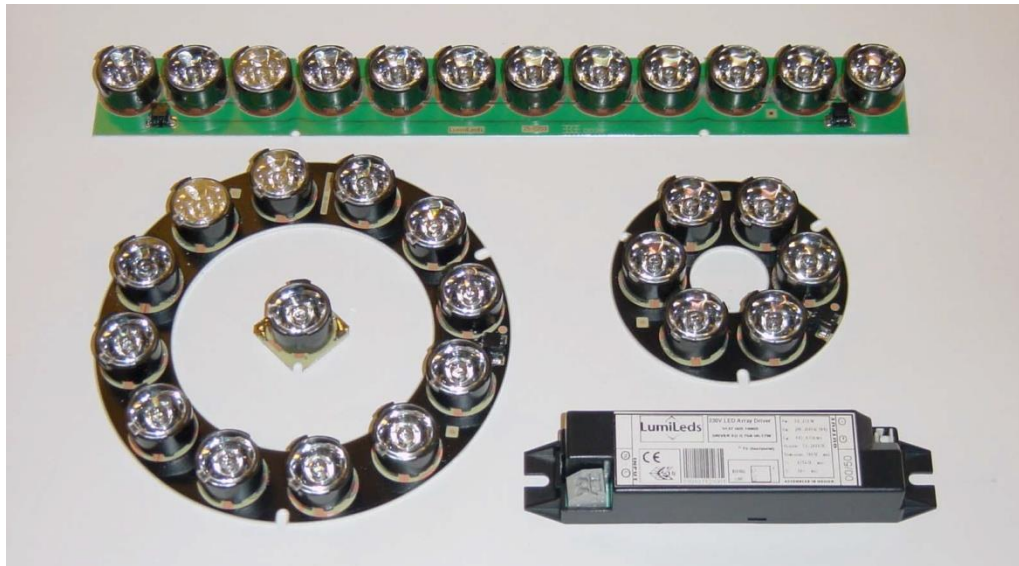

$A_{\text{chip}} \sim 1 \times 1 \text{ mm}^2$; $N = 4$

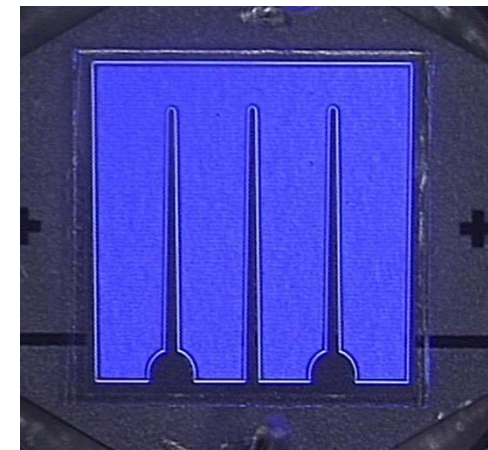
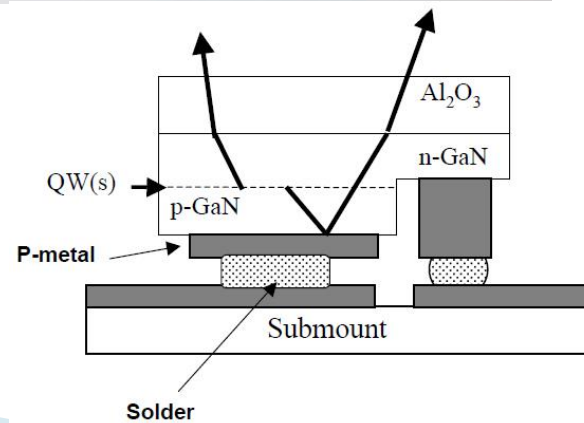

Performanta

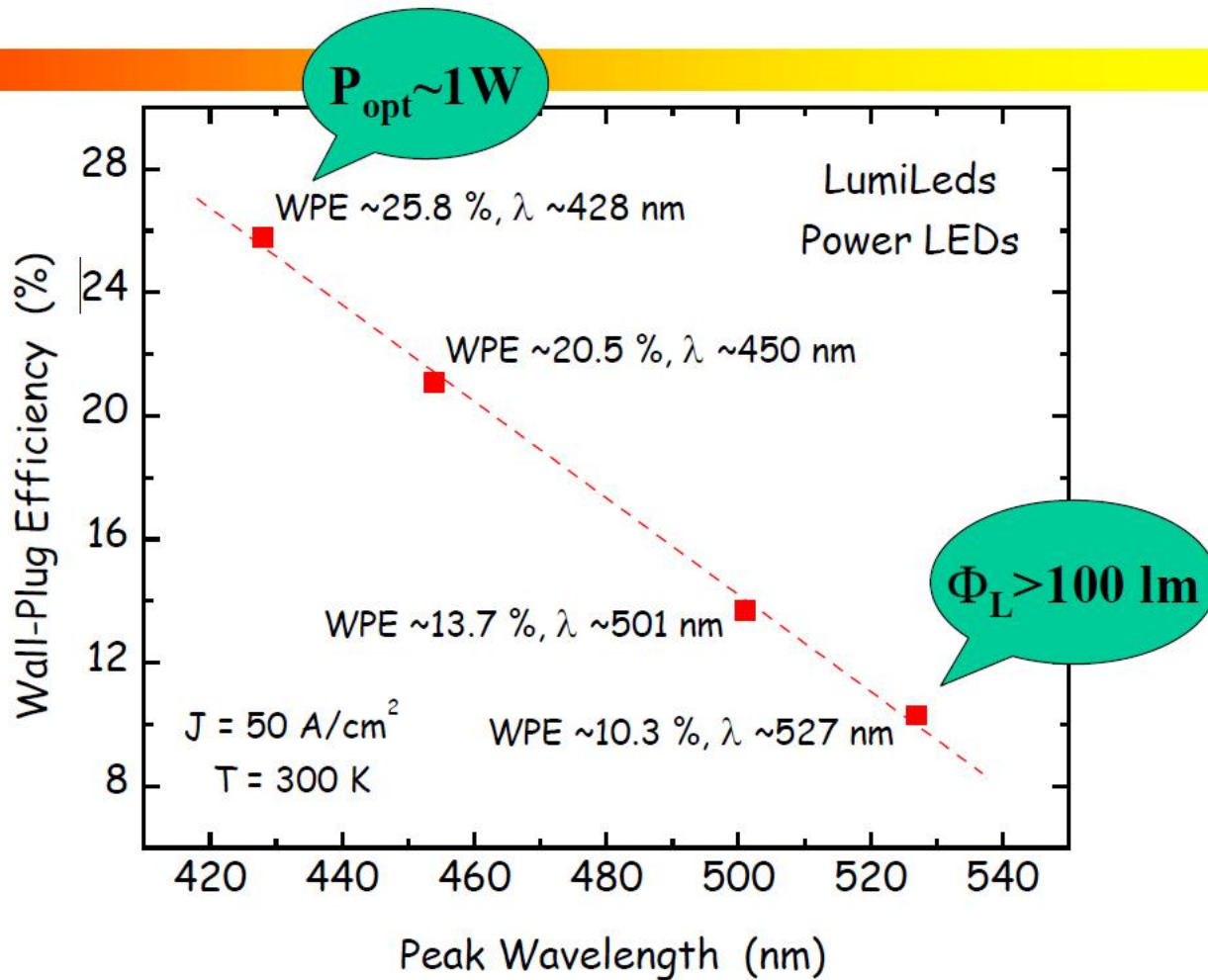

Aplicatii

▶ auto



Aplicatii

- ▶ casnic



Aplicatii

- ▶ iluminat public



Aplicatii

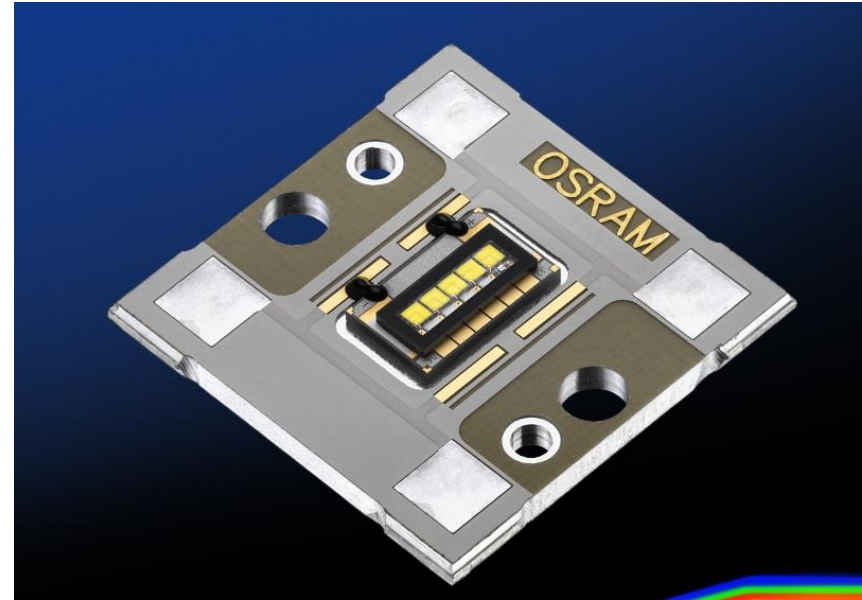

Avantaje

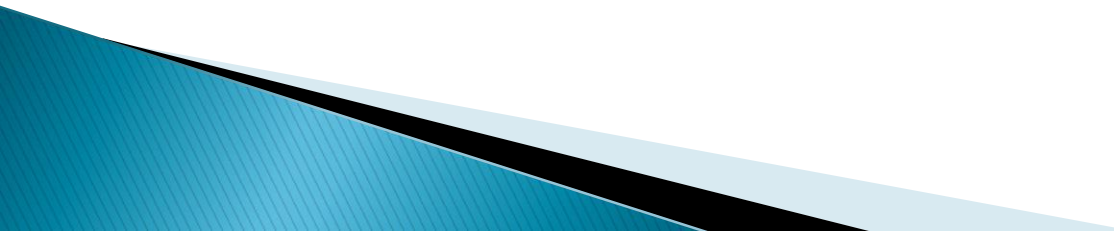
- ▶ Eficienta
 - ▶ Culoare usor de implementat (nativ)
 - ▶ Dimensiune
 - ▶ Timp de raspuns
 - ▶ Reglaj al intensitatii luminoase
 - ▶ Radiatie de caldura (IR) redusa
 - ▶ Timp de viata
 - ▶ Rezistenta la socuri
 - ▶ Directivitatea luminii (nativ)
- 

Dezavantaje

- ▶ Pret
- ▶ Dependenta de temperatura
- ▶ Sensibilitate la tensiune (prag)
- ▶ Calitatea luminii (corp negru)
- ▶ Directivitate (sursa de suprafata/punctuala)

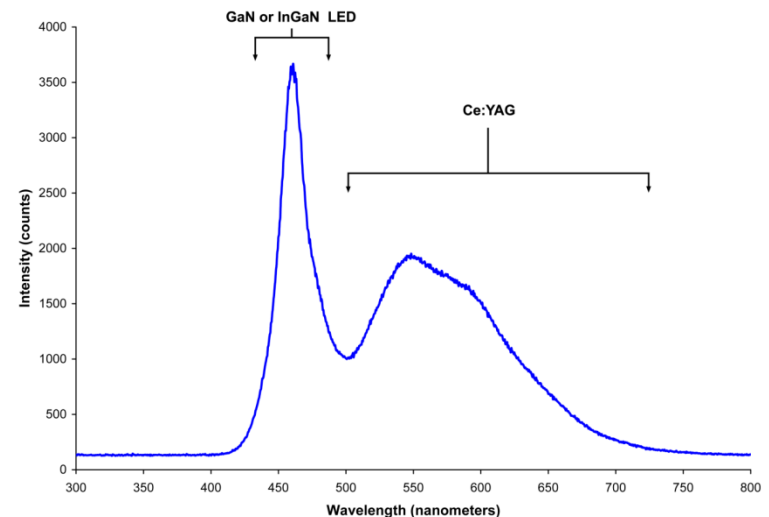
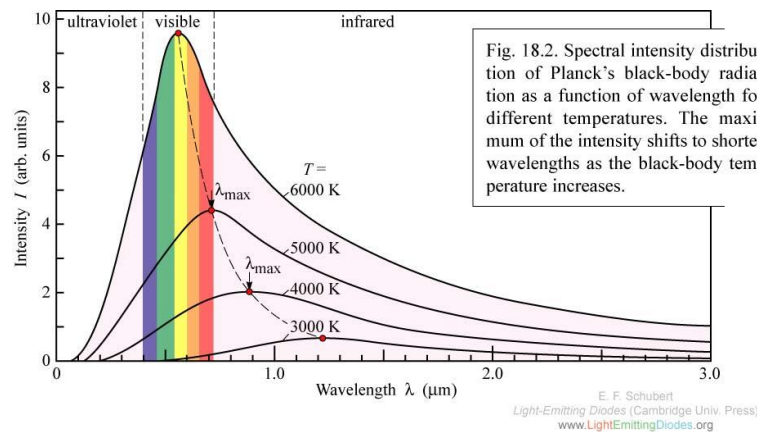

OLED

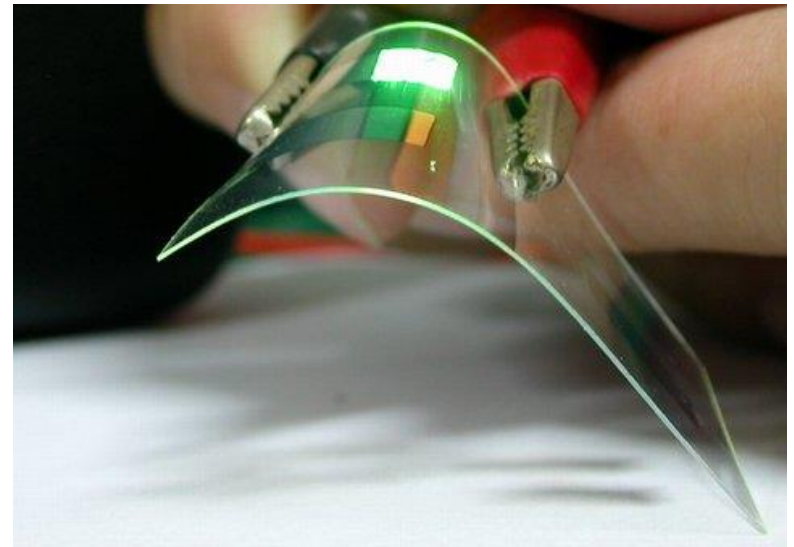
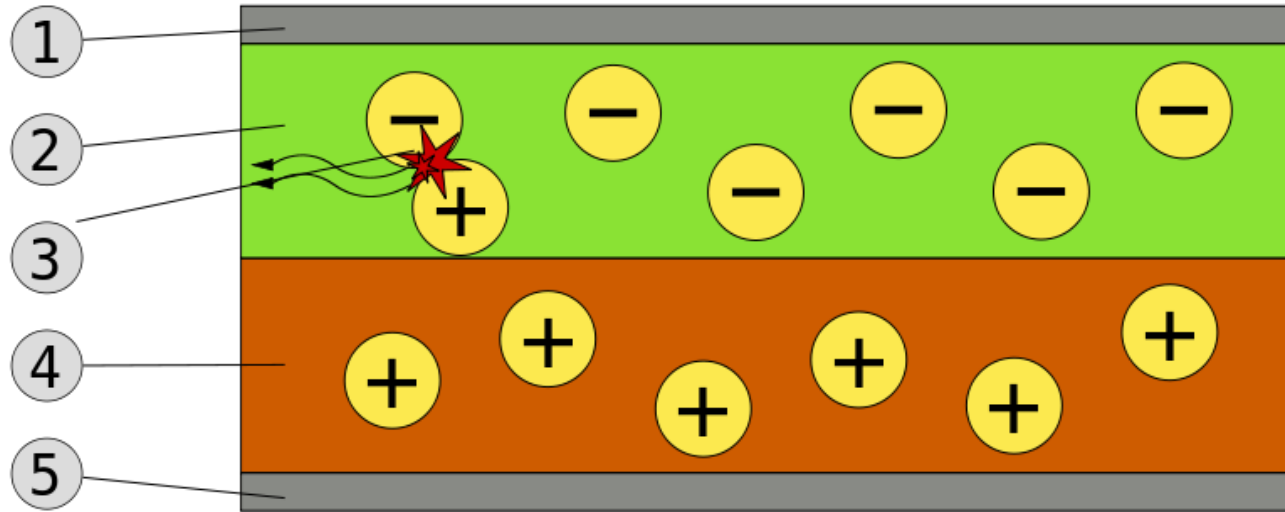

AMOLED

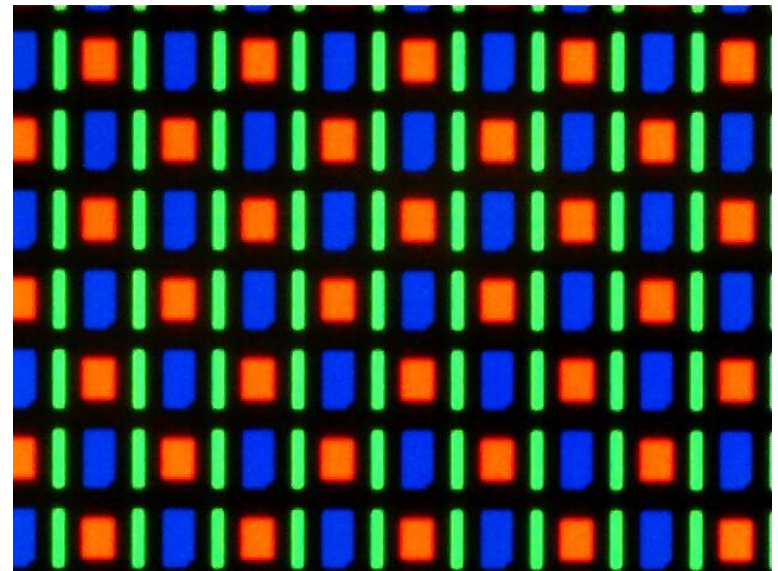
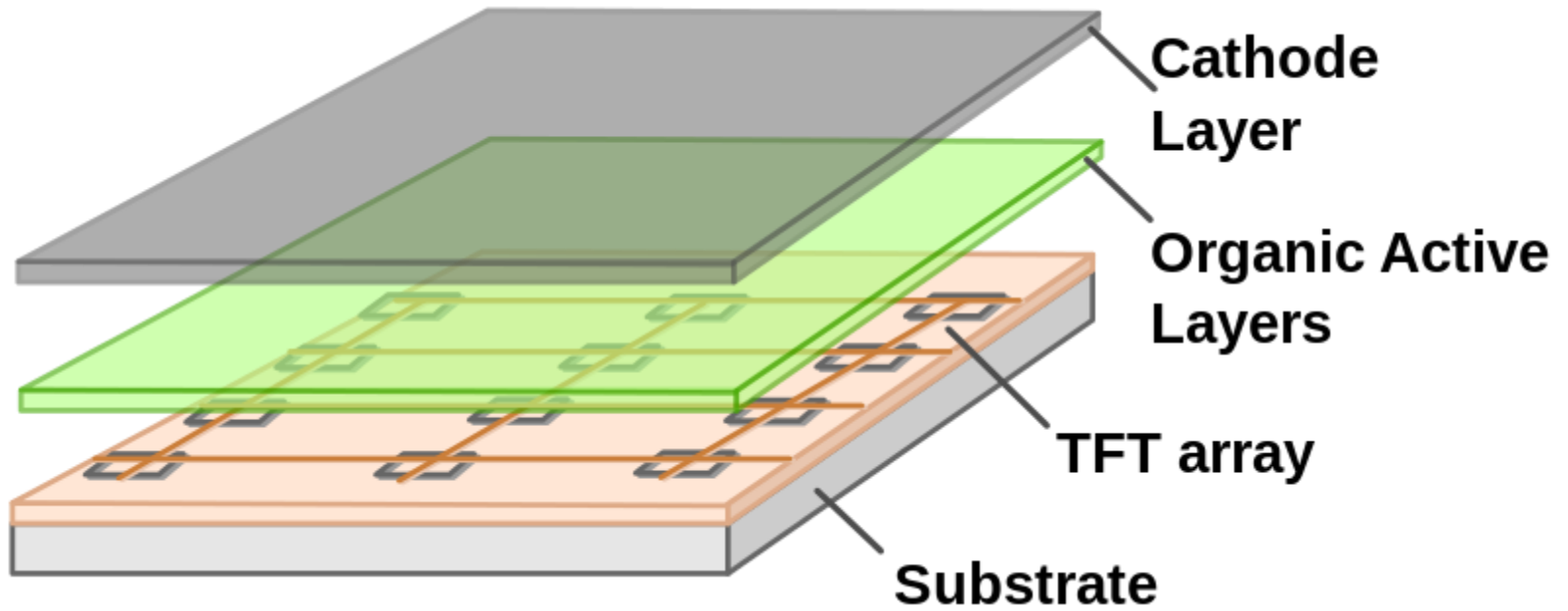

Caracteristica de raspuns a LED-urilor

- ▶ Caracteristica putere optica emisa functie de curentul direct prin LED este liniara la nivele mici ale curentului.
- ▶ Nu exista curent de prag
- ▶ La nivele foarte mari puterea optica se satureaza

- ▶ Responzivitatea

$$r = \frac{P_o}{I} \left[\frac{W}{A} \right]$$

- ▶ Tipic $r = 50 \mu W / mA$

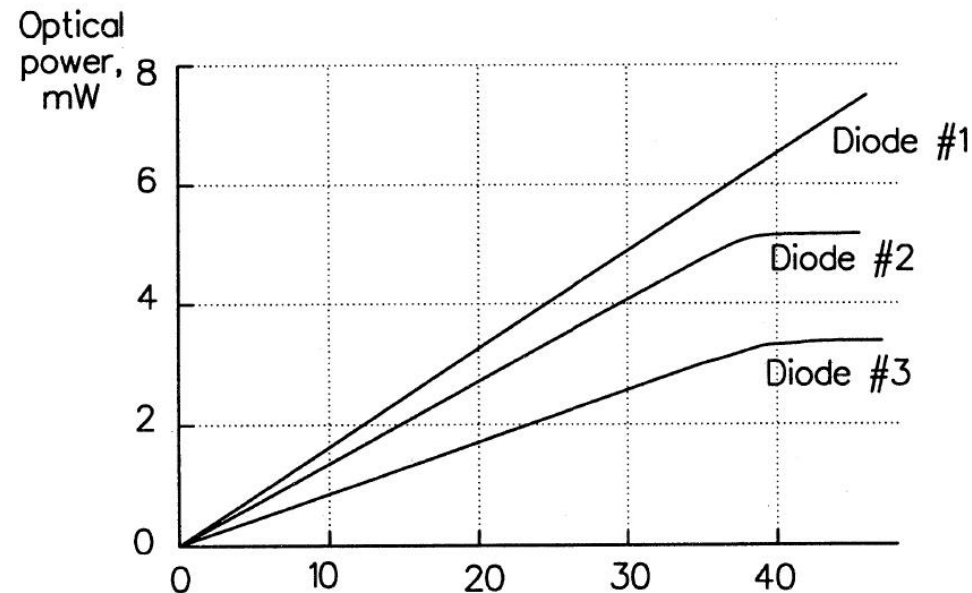

Control static LED

▶ Cea mai simpla schema de control: un rezistor in serie cu LED

- **Atentie!** Tensiunea directa poate varia semnificativ ($\gg 0.7V$) si trebuie preluata din catalog
 - mai ales la intensitate luminoasa mare
 - datorita materialelor diferite de realizare a LED-urilor
 - dependenta de lungimea de unda
 - mai mica la lungimi de unda mai mari

$$I_v = f(I_F [\text{mA}]) \quad [\text{cd/mcd}]$$

$$I_F = \frac{V_{cc} - V_F}{R}$$

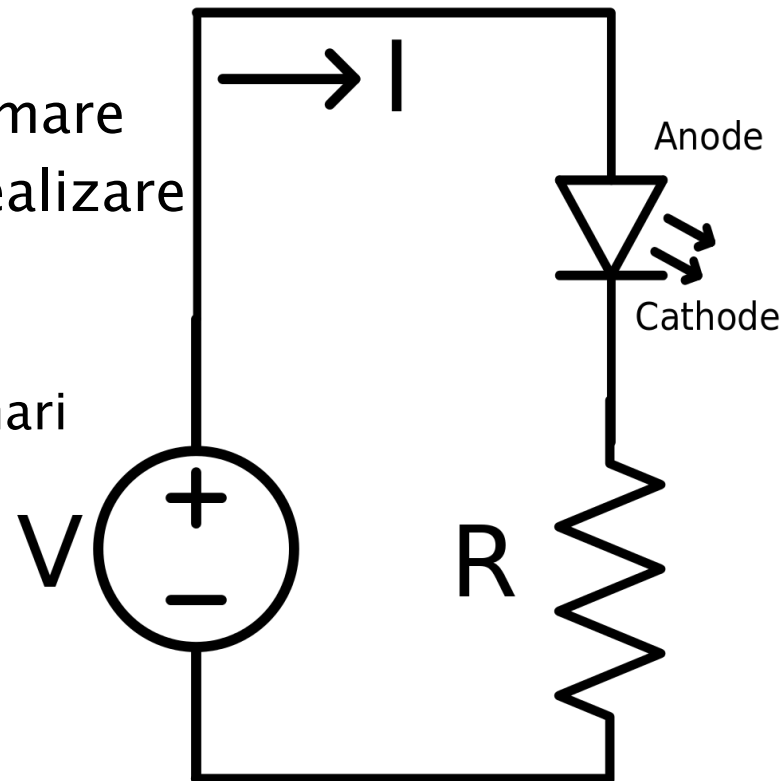

Control static LED



Ultra Bright LED Lamps Round Types

Package	Part No.	Chip			Absolute Maximum Ratings				Electro-optical Data(At 20mA)			Viewing Angle 2θ 1/2 (deg)	Drawing No.
		Material Emitted Color	Peak Wave Length p(nm)	Dominant Wave Length λd(nm)	Δλ (nm)	Pd (mw)	If (mA)	Peak (mA)	Vf (V)	Iv (mcd)	Typ.		
T-1 Standard 1.0" Lead 3φ Water Clear	BL-BF43V1	GaAlAs/ DDH Super Red	660	643 ± 5	20	80	30	150	2.0	2.6	700	25	L-001
	BL-BG33V1	InGaAlP/ Yellow Green	573	571 ± 5	15	100	30	150	2.2	2.6	700	25	
	BL-BG43V1	InGaN/SiC/ Bluish Green	505	505 ± 5	30	120	30	150	3.5	4.0	3500	24	
	BL-BG63V1	InGaN/SiC/ Green	525	525 ± 5	35	120	30	150	3.5	4.0	4000	24	
	BL-BJ23V1	InGaAlP/ Super Orange	620	615 ± 5	17	100	30	150	2.2	2.6	1700	25	
	BL-BJ33V1	InGaAlP/ Super Orange	630	625 ± 5	17	100	30	150	2.2	2.6	1100	25	
	BL-BJ63V1	InGaAlP/ Super Orange	610	605 ± 5	17	100	30	150	2.2	2.6	1500	25	
	BL-BJ73V1	InGaAlP/ Super Orange	630	625 ± 5	17	100	30	150	2.2	2.6	1500	25	
	BL-BJH3V1	InGaAlP/ Super Orange	630	625 ± 5	17	100	30	150	2.2	2.6	2500	25	
	BL-BJG3V1	InGaAlP/ Super Orange	630	625 ± 5	17	100	30	150	2.2	2.6	3000	25	
	BL-BK43V1	InGaAlP/ Super Yellow	590	587 ± 5	15	100	30	150	2.2	2.6	1600	25	
	BL-BK53V1	InGaAlP/ Super Yellow	595	594 ± 5	15	100	30	150	2.2	2.6	1500	25	
	BL-BK73V1	InGaAlP/ Super Yellow	595	594 ± 5	15	100	30	150	2.2	2.6	2000	25	
	BL-BK83V1	InGaAlP/ Super Yellow	590	587 ± 5	15	100	30	150	2.2	2.6	2000	25	
	BL-BKH3V1	InGaAlP/ Super Yellow	590	587 ± 5	15	100	30	150	2.2	2.6	2500	25	
	BL-BKG3V1	InGaAlP/ Super Yellow	590	587 ± 5	15	100	30	150	2.2	2.6	3000	25	
BL-BF43V4V	GaAlAs/ DDH Super Red	660	643 ± 5	20	80	30	150	2.0	2.6	1200	15		
BL-BG33V4V	InGaAlP/ Yellow Green	573	571 ± 5	15	100	30	150	2.2	2.6	1100	15		
BL-BG43V4V	InGaN/SiC/ Bluish Green	505	505 ± 5	30	120	30	150	3.5	4.0	6000	24		
BL-BG63V4V	InGaN/SiC/ Green	525	525 ± 5	35	120	30	150	3.5	4.0	5600	24		

3.5	4.0	3500
3.5	4.0	4000
2.2	2.6	1700
2.2	2.6	1100

◆ Electro-Optical Characteristics

Item	Symbol	Condition	Minimum	Typical	Maximum	Unit
Forward Voltage	V _F	I _F = 240 mA		19.0		V
Brightness	I _v	I _F = 240 mA		13		cd
Total Radiated Power	P _o	I _F = 240 mA		60		mW

Control dinamic LED

- ▶ Variatii mici ale tensiunii (mai ales in jurul tensiunii de deschidere) pot duce la varii mari ale curentului
- ▶ Se prefera de multe ori controlul in curent al LED-ului

Control dinamic LED, Lab 1

- ▶ Control in tensiune
 - Schema electrică a emițătorului în impuls

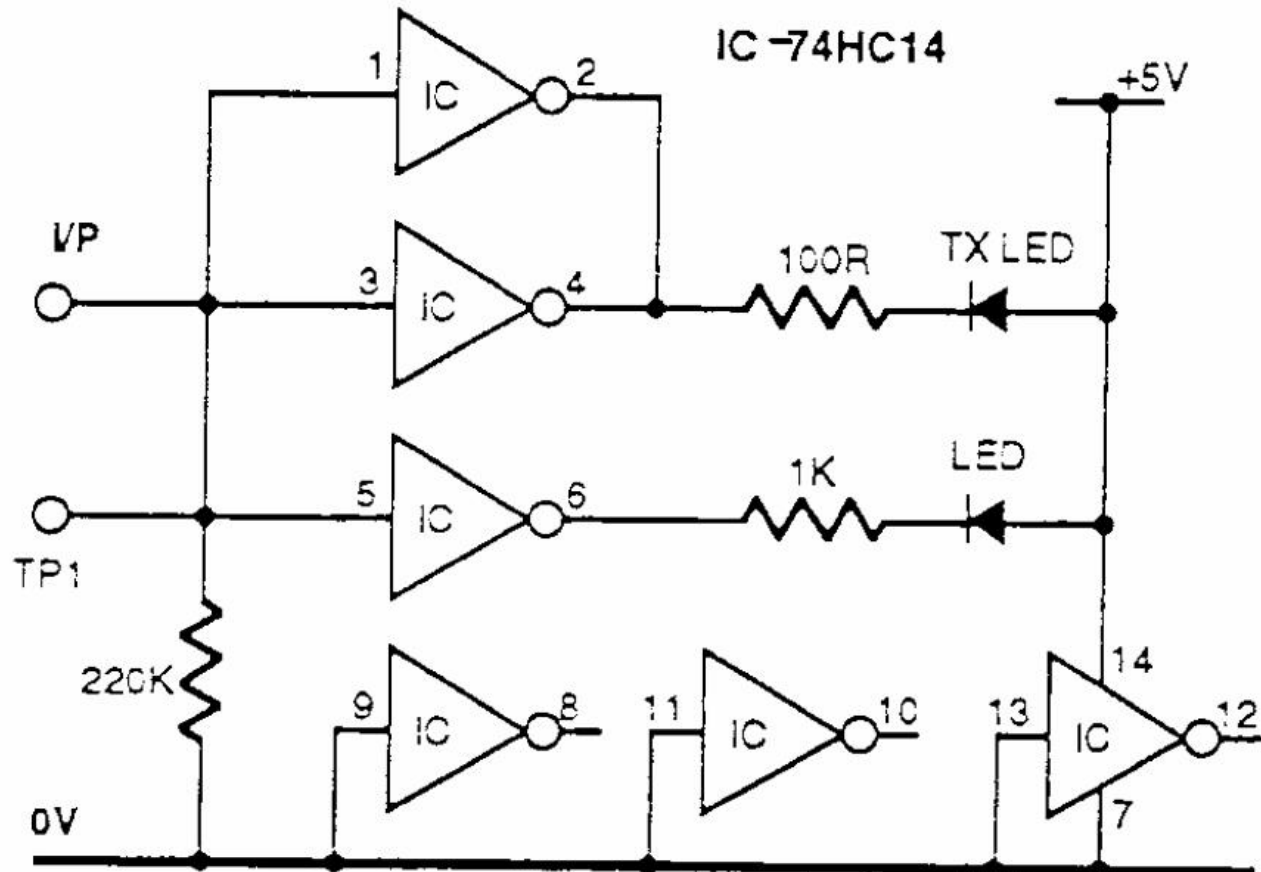

Control dinamic LED, Lab 1

- ▶ Control in curent
 - Schema electrică a emițătorului optic analogic

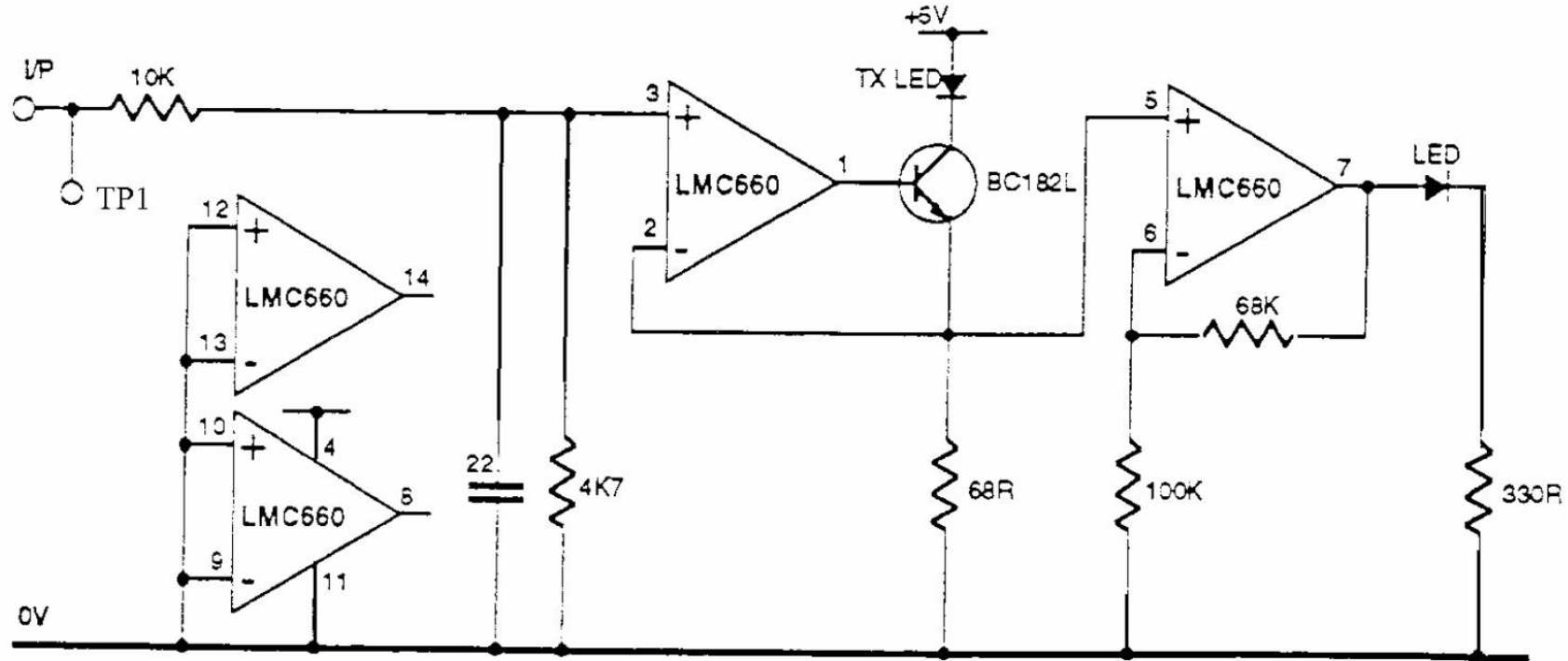

Dioda Laser

Capitolul 8

Cuprins

- ▶ **Lumina ca undă electromagnetică** (ecuațiile lui Maxwell, ecuația undelor, parametri de propagare)
- ▶ **Elemente de fotometrie și radiometrie** (mărimi energetice/luminoase)
- ▶ **Fibra optică** (realizare, principiu de funcționare, atenuare, dispersie, banda de frecvență)
- ▶ **Cabluri optice** (tehnologie, conectori, lipire – splice)
- ▶ **Proiectare sistemică a legăturii pe fibra optică** (bandă de frecvență, balanța puterilor)
- ▶ **Emițătoare optice** (LED și dioda laser – realizare fizică și funcționare)
- ▶ **Receptoare optice** (dioda PIN, dioda cu avalanșă – realizare fizică și funcționare)
- ▶ **Amplificatoare transimpedanță** (parametri, scheme tipice, TIA în buclă deschisă, cu reacție, diferențiale, control automat al câștigului)
- ▶ **Realizarea circuitelor pentru controlul emițătoarelor optice** (parametri, scheme tipice, controlul puterii, multiplexoare)
- ▶ **Dispozitive de captare a energiei solare** (principiu de funcționare, utilizare, proiectare)

Caracteristici dioda laser

▶ Avantaje

- Putere optica ridicata (50mW functionare continua, 4W functionare in impulsuri)
- Precizie ridicata a controlului (impulsuri cu latimea de ordinul fs – femptosecunde) – viteza mare de lucru
- Spectru ingust, teoretic LASER ofera o singura linie spectrala
- Lumina coerenta si directiva (~80% poate fi cuplata in fibra)

▶ Dezavantaje

- Cost (dispozitiv si circuit de comanda: controlul puterii si al temperaturii)
- Durata de viata
- Sensitivitate crescuta cu temperatura
- Modulatie analogica dificila (de obicei cu dispozitive externe)
- Lungime de unda fixa

Dioda LASER – Principiu de operare

- ▶ LASER = Light Amplification by the Stimulated Emission of Radiation = Amplificarea Luminiilor prin Emisie Stimulată
- ▶ Un foton incident poate cauza prin absorbție tranziția unui electron pe un nivel energetic superior

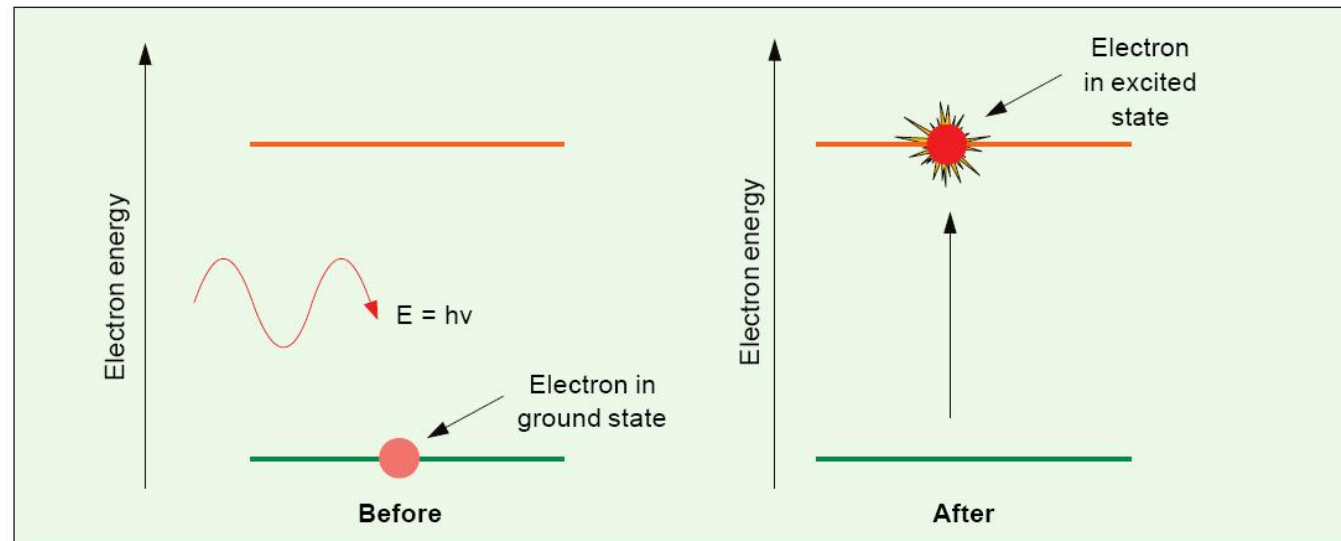

Dioda LASER – Principiu de operare

- ▶ Emisia spontana – electronul trece in starea energetica de echilibru emitand un foton
- ▶ Trecerea se realizeaza prin recombinarea unei perechi electron–gol
- ▶ Directia si faza radiatiei emise sunt aleatoare

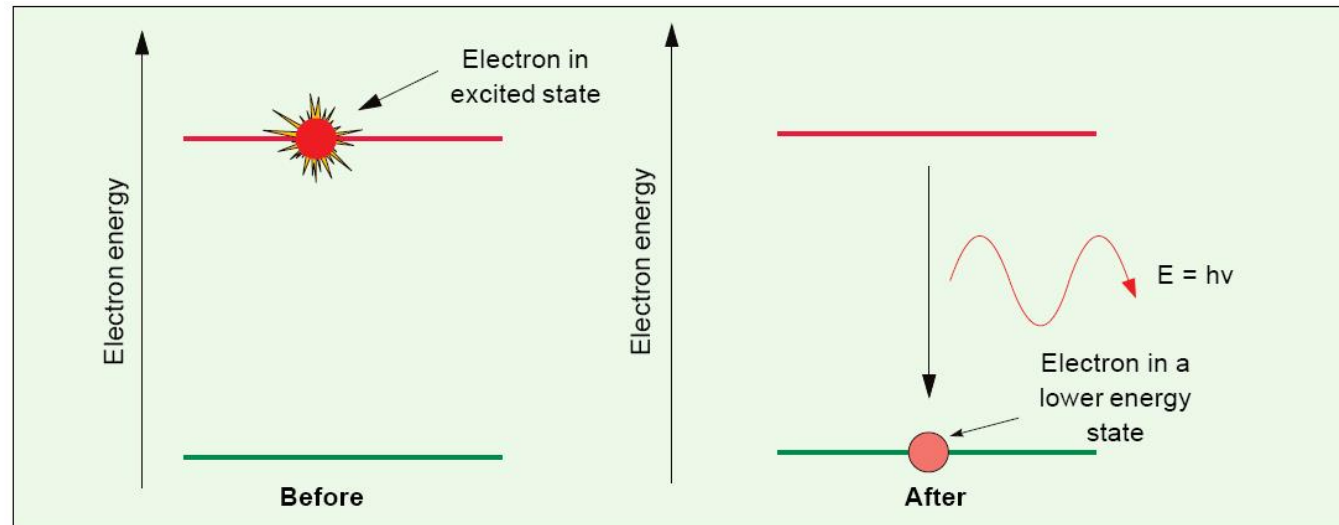

Dioda LASER – Principiu de operare

- ▶ Emisia stimulata – un foton incident cu energie corespunzatoare poate stimula emisia unui al doilea foton **fara a fi absorbit**
- ▶ Noul foton are aceeasi directie si faza cu fotonul incident, Lumina rezultata e coerenta

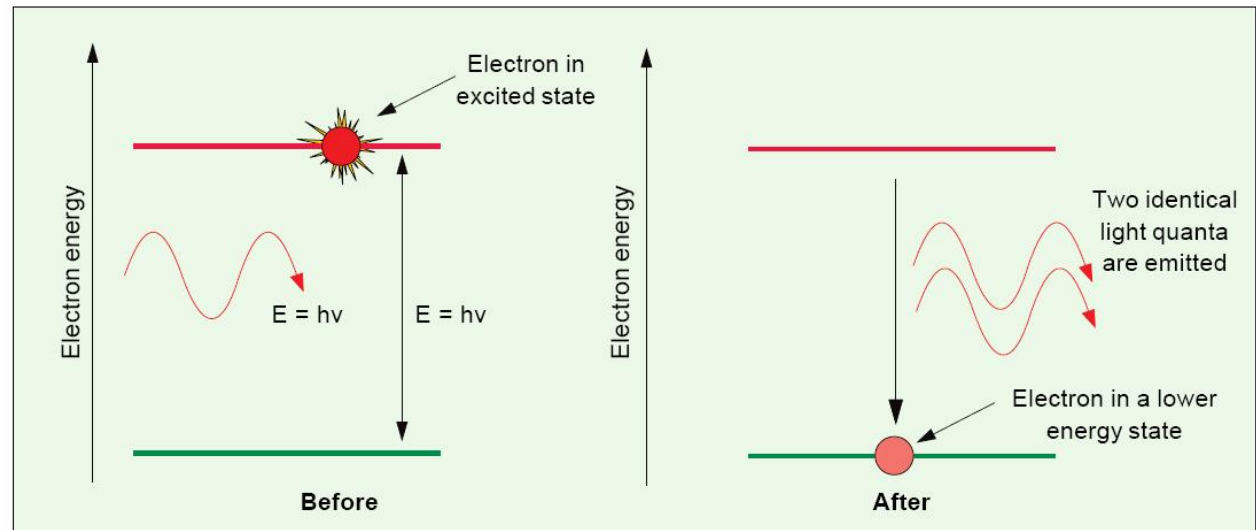

Detalii constructive

- ▶ Recombinarea unei perechi electron–gol necesita conservarea impulsului
- ▶ In Si si Ge aceasta conditie presupune aparitia unui foton intermediar (tranzitie indirecta) a carui energie se transforma in caldura
- ▶ Se utilizeaza aliaje de Ga Al As sau In Ga As P
- ▶ Spatierea atomilor in diferitele straturi trebuie sa fie egala (toleranta 0.1%) pentru a nu se introduce defecte mecanice la jonctiune
 - limitare a aliajelor utilizabile
 - aparitia defectelor
 - creste ineficienta (recombinari neradiative)
 - scade durata de viata a dispozitivului

Lățimea benzii interzise/lungime de undă pentru materialele uzuale

Material	Formula	Wavelength Range λ (μm)	Bandgap Energy W_g (eV)
Indium Phosphide	InP	0.92	1.35
Indium Arsenide	InAs	3.6	0.34
Gallium Phosphide	GaP	0.55	2.24
Gallium Arsenide	GaAs	0.87	1.42
Aluminium Arsenide	AlAs	0.59	2.09
Gallium Indium Phosphide	GaInP	0.64-0.68	1.82-1.94
Aluminium Gallium Arsenide	AlGaAs	0.8-0.9	1.4-1.55
Indium Gallium Arsenide	InGaAs	1.0-1.3	0.95-1.24
Indium Gallium Arsenide Phosphide	InGaAsP	0.9-1.7	0.73-1.35

$$E_g = h\nu; \quad \lambda = \frac{hc}{E_g}; \quad \lambda[\mu\text{m}] = \frac{1.240}{E_g[\text{eV}]}$$

- ▶ h constanta lui Plank
 $6.6261 \cdot 10^{-34} \text{ W s}^2$
- ▶ c viteza luminii **in vid**
 $2.998 \cdot 10^8 \text{ m/s}$
- ▶ e sarcina electronului
 $1.6 \cdot 10^{-19} \text{ C}$
- ▶ benzi energetice: λ_0 , $\Delta\lambda$

Dependența benzii interzise de constanta rețelei

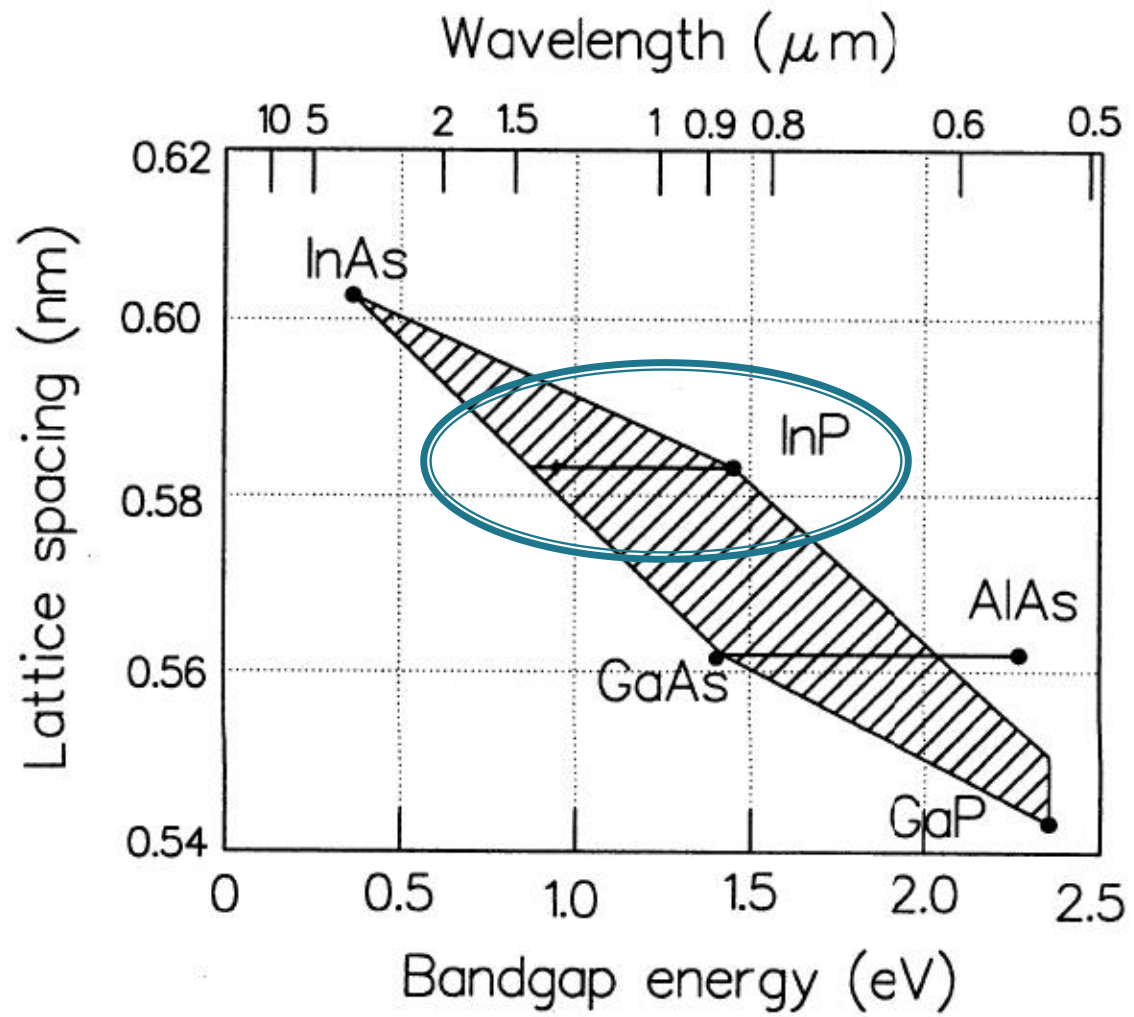
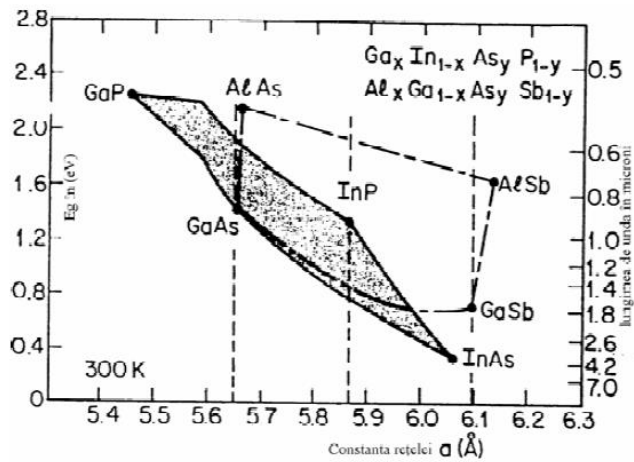

Materiale

- ▶ Lungimi de unda mici (spectru vizibil – 1000nm)
 - GaP (665nm), $\text{GaAs}_y\text{P}_{1-y}$
 - GaAs (900nm), $\text{Ga}_{1-x}\text{Al}_x\text{As}$ (AlAs – 550nm)
- ▶ Lungimi de unda mari (1000÷1700nm)
 - $\text{In}_x\text{Ga}_{1-x}\text{As}_y\text{P}_{1-y}$
 - x,y concentratii relative in aliaj a materialelor corespunzatoare
 - x,y alese din considerente privind
 - lungimea de unda
 - spatierea atomilor

Materiale

- ▶ Lungimi de unda mici
 - $\text{Ga}_{1-x}\text{Al}_x\text{As}$
 - substrat GaAs
 - limitare pentru tranzitie directa, $x < 0.45$
 - E_g (in eV)

$$E_g = 1.424 + 1.247 \cdot x, \quad x < 0.45$$

$$E_g = 1.9 + 0.125 \cdot x + 0.143 \cdot x^2, \quad x > 0.45$$

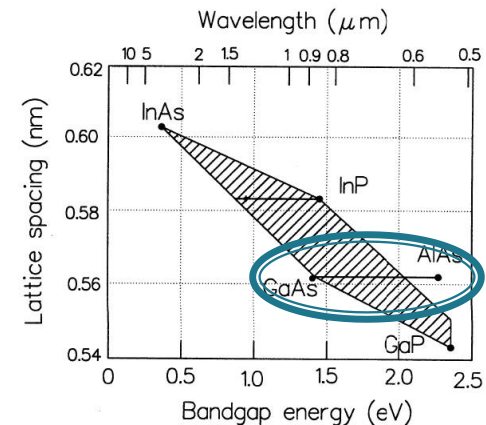
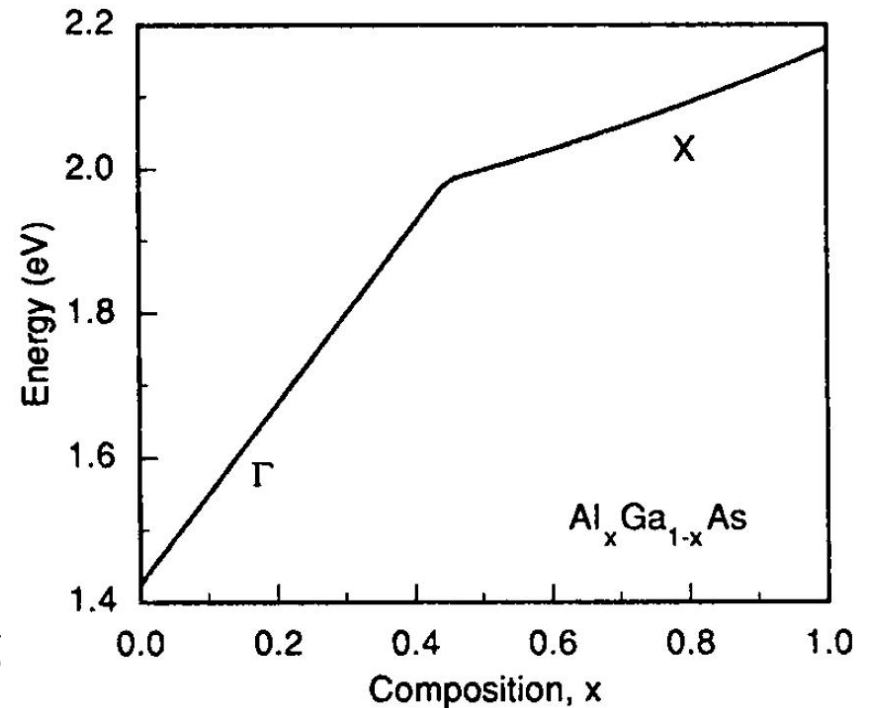

Materiale

- ▶ Lungimi de unda mari
 - $\text{In}_x\text{Ga}_{1-x}\text{As}_y\text{P}_{1-y}$
 - Tipic substratul este InP
 - Spatierea atomilor (lattice spacing) corespunzatoare InP

$$x = \frac{0.4526 \cdot y}{1 - 0.031 \cdot y}$$

- E_g (in eV)

$$E_g = 1.35 - 0.72 \cdot y + 0.12 \cdot y^2$$

- Exemplu: 1300nm se obtine cu $y=0.611$ si $x=0.282$,

- $\text{In}_{0.282}\text{Ga}_{0.718}\text{As}_{0.611}\text{P}_{0.389}$

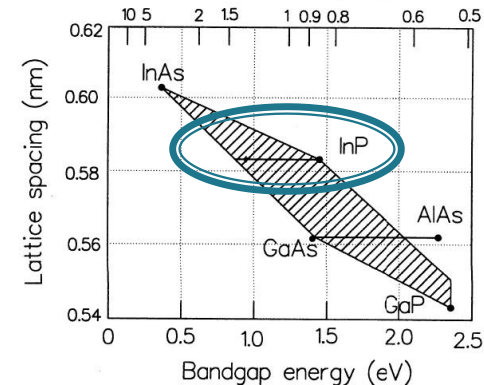
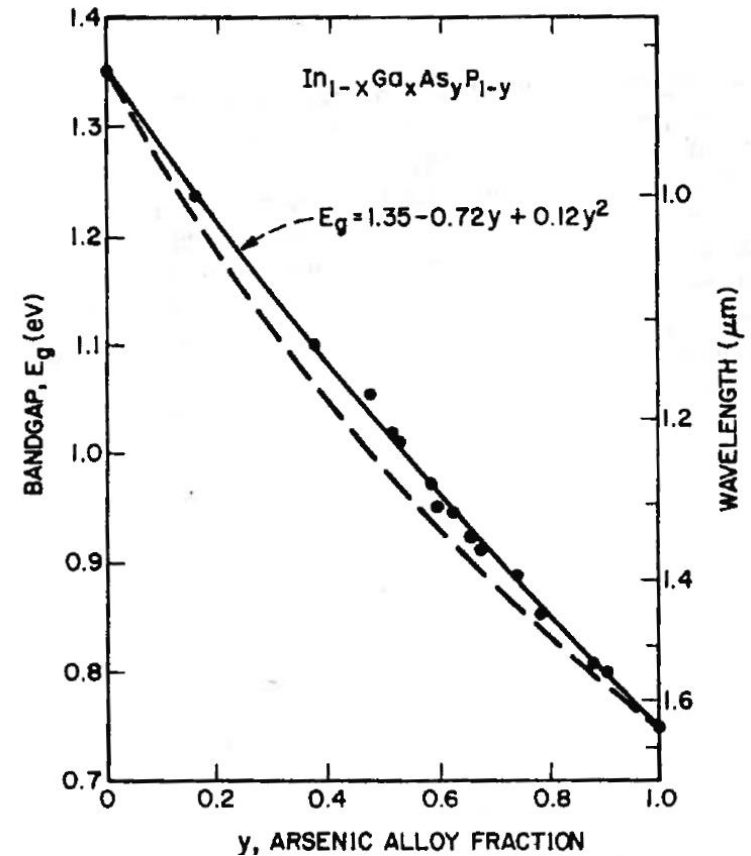

Principii LASER

- ▶ Inversiune de populatie
 - necesara deoarece electronii au capabilitatea de a absorbi energie **la aceeasi frecventa** la care are loc emisia stimulata
 - se defineste probabilistic: probabilitatea de emisie stimulata sa fie mai mare decat probabilitatea de absorbtie

$$n_c \cdot p_e > n_v \cdot p_a$$

- ▶ Materialele capabile sa genereze inversiune de populatie au starea excitata metastabila

Materialie cu 4 nivele energetice

- ▶ La un material cu 4 nivele energetice tranzitia radianta a electronului (3) se termina intr-o stare instabila, starea de echilibru obtinandu-se prin emisia unui fonon
- ▶ Inversiunea de populatie se obtine mult mai usor datorita electronilor din starea intermediara

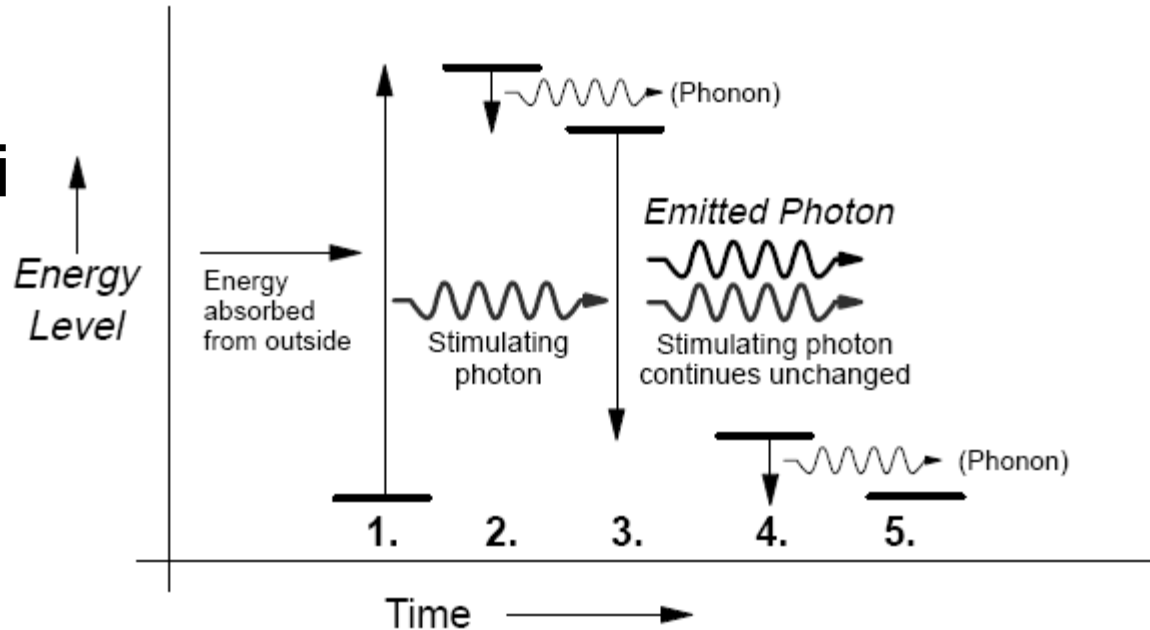

Dioda LASER – Principiu de realizare

- ▶ Pentru ca emisia stimulata sa apara, fotonii emisi trebuie sa ramana in contact cu materialul o perioada mai mare de timp – 2 oglinzi necesare
- ▶ Pentru a permite extragerea radiatiei e necesar ca una din oglinzi sa fie partial reflectanta

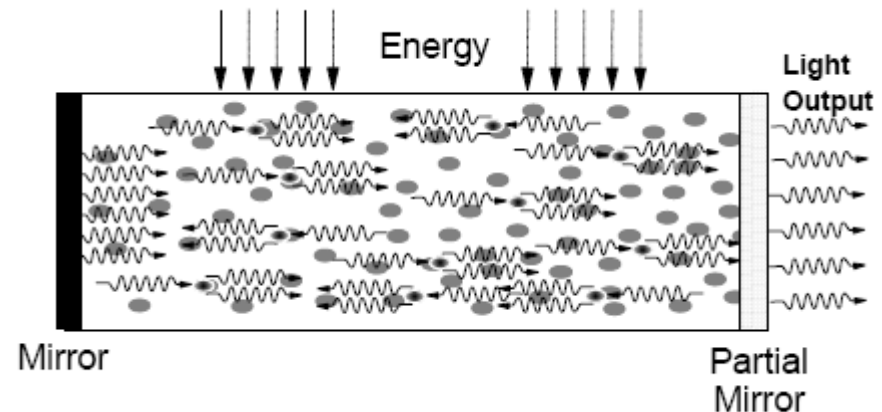

Dioda LASER – Principiu de realizare

- ▶ Pentru diodele laser utilizate in comunicatii reflectivitatea oglinzilor nu trebuie sa fie foarte mare
- ▶ Interfata semiconductor aer ofera un coeficient de reflexie de $\sim 6\%$ dar poate ajunge la 36% pentru lungimea de unda de operare (vezi lamela dielectrica)

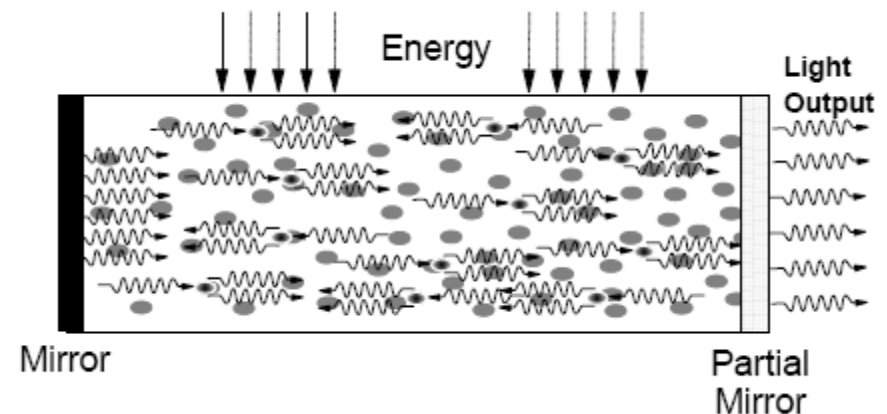
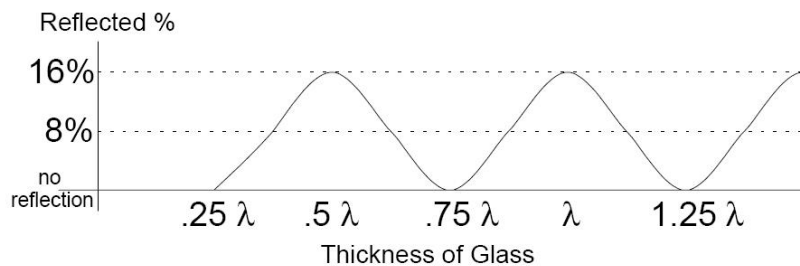

Dioda LASER – Principiu de realizare

- ▶ Pentru a realiza
 - coerența radiației
 - interferența constructivă între radiațiile incidente și reflectate de oglinzi,
- ▶ distanța între oglinzi trebuie să fie un multiplu al jumătății din lungimea de undă

$$L = k \cdot \frac{1}{2} \cdot \frac{\lambda_0}{n} \qquad L = k \cdot \frac{c_0}{2 \cdot n \cdot f} \qquad f = k \cdot \frac{c_0}{2 \cdot n \cdot L}$$

- ▶ Pentru eficientizarea pomparii de energie din exterior $L = 100 \div 200 \mu\text{m}$, $k \cong 400$

Contact

- ▶ Laboratorul de microunde si optoelectronica
- ▶ <http://rf-opto.etti.tuiasi.ro>
- ▶ rdamian@etti.tuiasi.ro