

Optoelectronică

Curs 7

2019/2020

Disciplina 2019/2020

- ▶ 2C/1L Optoelectronică **OPTO**
- ▶ ~~Minim 7 prezente curs + laborator~~
- ▶ Curs – conf. **Radu Damian**
 - an IV μ E
 - Vineri 8–11, P5
 - E – 70% din nota
 - **20% test la curs**, saptamana 4–5?
 - probleme + (? 1 subiect teorie) + (2p prez. curs)
 - toate materialele permise
- ▶ Laborator – **sl. Daniel Matasaru**
 - an IV μ E
 - Joi 8-14 impar
 - L – 30% din nota (+Caiet de laborator)

Reprezentare logaritmică!!!

$$\text{dB} = 10 \cdot \log_{10} (P_2 / P_1)$$

$$\text{dBm} = 10 \cdot \log_{10} (P / 1 \text{ mW})$$

$$0 \text{ dB} = 1$$

$$+ 0.1 \text{ dB} = 1.023 (+2.3\%)$$

$$+ 3 \text{ dB} = 2$$

$$+ 5 \text{ dB} = 3$$

$$+ 10 \text{ dB} = 10$$

$$-3 \text{ dB} = 0.5$$

$$-10 \text{ dB} = 0.1$$

$$-20 \text{ dB} = 0.01$$

$$-30 \text{ dB} = 0.001$$

$$0 \text{ dBm} = 1 \text{ mW}$$

$$3 \text{ dBm} = 2 \text{ mW}$$

$$5 \text{ dBm} = 3 \text{ mW}$$

$$10 \text{ dBm} = 10 \text{ mW}$$

$$20 \text{ dBm} = 100 \text{ mW}$$

$$-3 \text{ dBm} = 0.5 \text{ mW}$$

$$-10 \text{ dBm} = 100 \mu\text{W}$$

$$-30 \text{ dBm} = 1 \mu\text{W}$$

$$-60 \text{ dBm} = 1 \text{ nW}$$

$$[\text{dBm}] + [\text{dB}] = [\text{dBm}]$$

$$[\text{dBm/Hz}] + [\text{dB}] = [\text{dBm/Hz}]$$

$$[\text{x}] + [\text{dB}] = [\text{x}]$$

Calculul atenuarii

$$\text{Pierderi} = \frac{P_{out}}{P_{in}}$$

$$\text{Pierderi[dB]} = [-] 10 \cdot \log_{10} \left(\frac{P_{out}}{P_{in}} \right)$$

$$\text{Pierderi[dB]} = [-] 10 \cdot \log_{10} \left(\frac{P_{out}}{P_0} \cdot \frac{P_0}{P_{in}} \right) = [-] 10 \cdot \left[\log_{10} \left(\frac{P_{out}}{P_0} \right) - \log_{10} \left(\frac{P_{in}}{P_0} \right) \right]$$

$$\text{Pierderi [dB]} = [-] (P_{out} [\text{dBm}] - P_{in} [\text{dBm}])$$



=



-

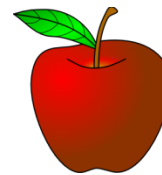

$$\text{Atenuare[dB/km]} = \frac{\text{Pierderi[dB]}}{\text{lungime[km]}}$$

Utilizare celule solare

Capitolul 9

Cuprins

- ▶ **Lumina ca undă electromagnetică** (ecuațiile lui Maxwell, ecuația undelor, parametri de propagare)
- ▶ **Elemente de fotometrie și radiometrie** (mărimi energetice/luminoase)
- ▶ **Fibra optică** (realizare, principiu de funcționare, atenuare, dispersie, banda de frecvență)
- ▶ **Cabluri optice** (tehnologie, conectori, lipire – splice)
- ▶ **Proiectare sistemică a legăturii pe fibra optică** (bandă de frecvență, balanța puterilor)
- ▶ **Emițătoare optice** (LED și dioda laser – realizare fizică și funcționare)
- ▶ **Receptoare optice** (dioda PIN, dioda cu avalanșă – realizare fizică și funcționare)
- ▶ **Amplificatoare transimpedanță** (parametri, scheme tipice, TIA în buclă deschisă, cu reacție, diferențiale, control automat al câștigului)
- ▶ **Realizarea circuitelor pentru controlul emițătoarelor optice** (parametri, scheme tipice, controlul puterii, multiplexoare)
- ▶ **Dispozitive de captare a energiei solare** (principiu de funcționare, utilizare, proiectare)

Efect fotovoltaic

▶ joncțiunea pn

Energy level

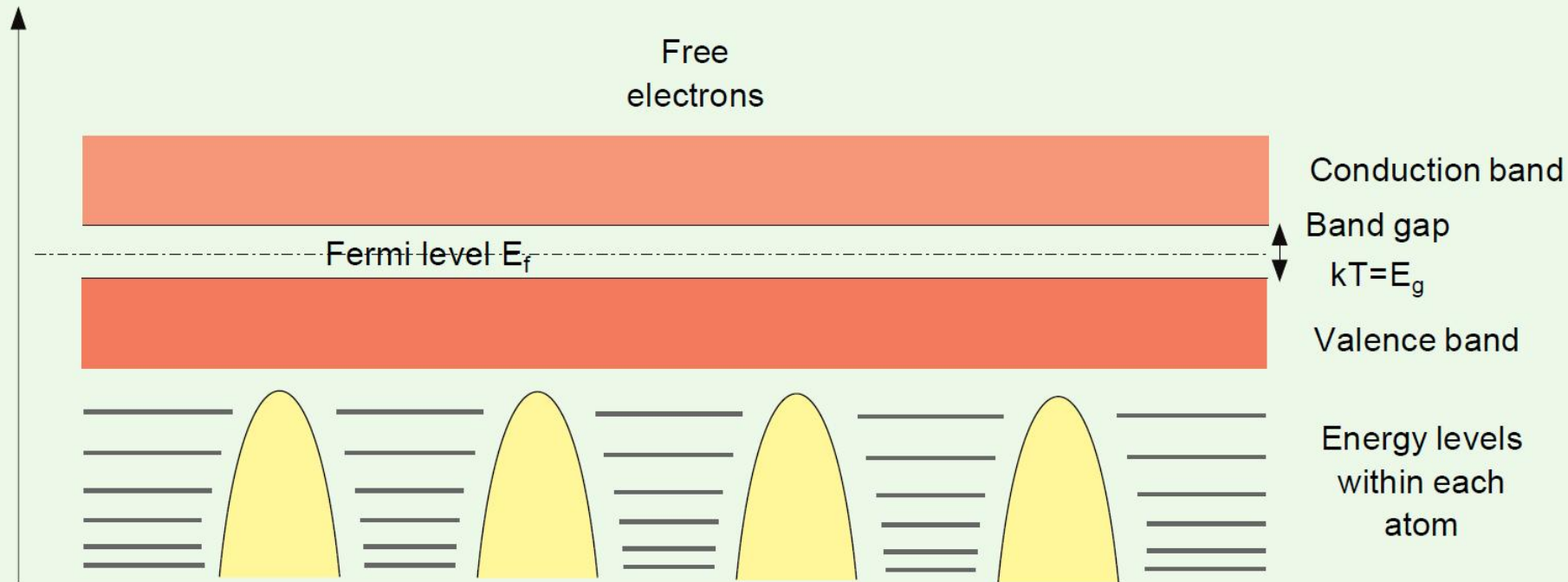

Efect fotovoltaic

▶ joncțiunea pn

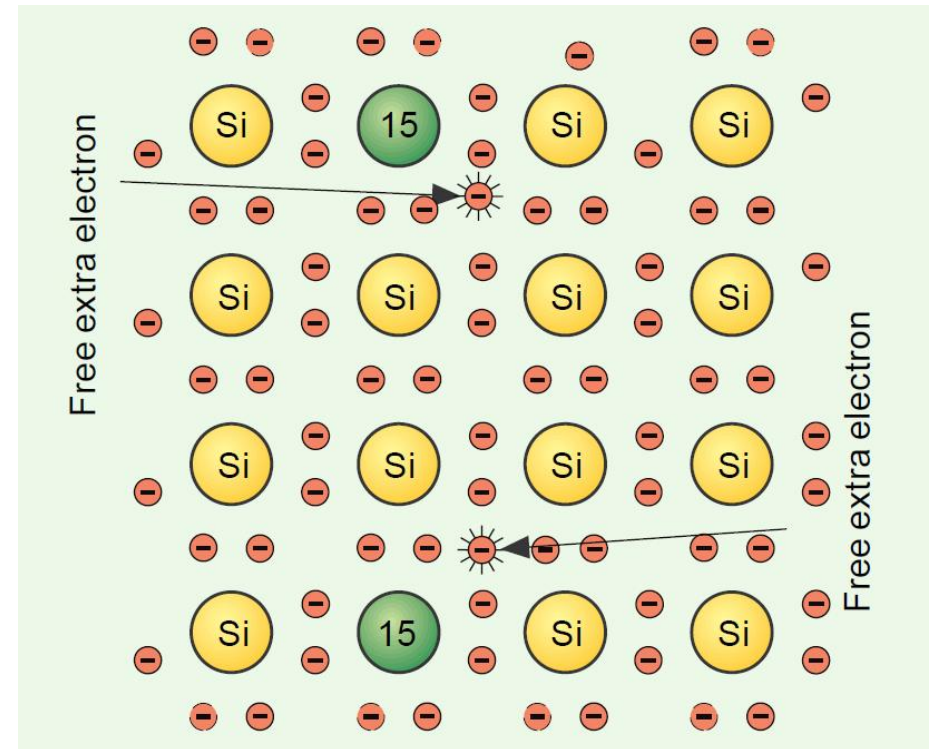
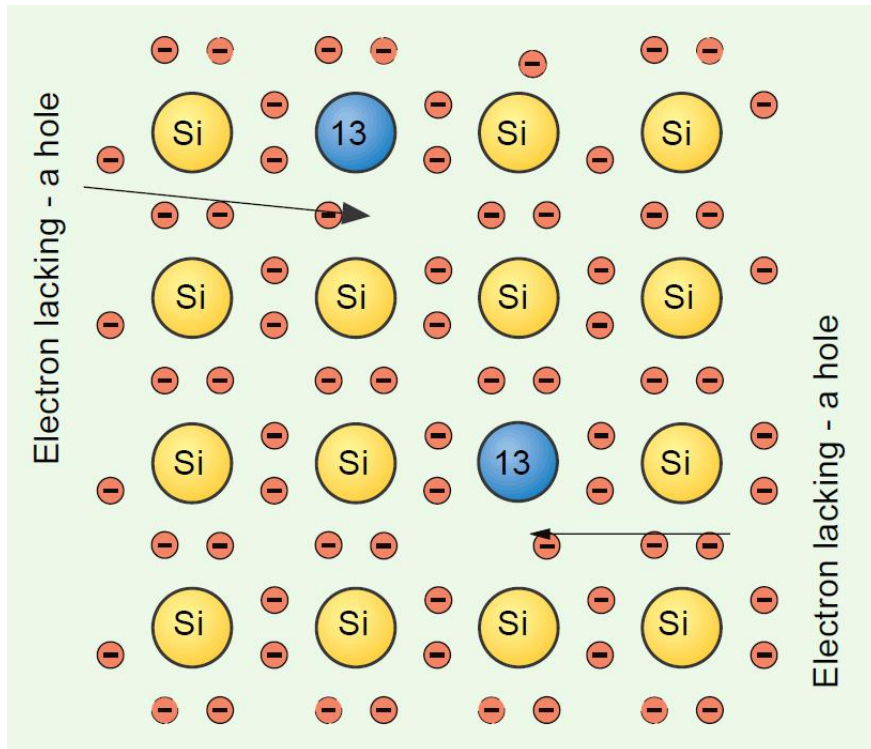

Efect fotovoltaic

▶ joncțiunea pn

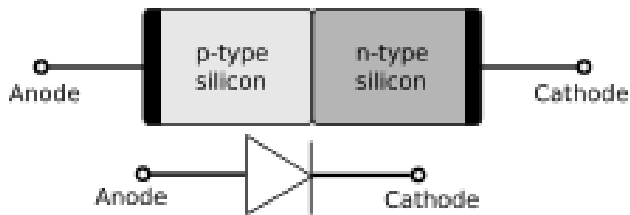

$$V > V_D$$

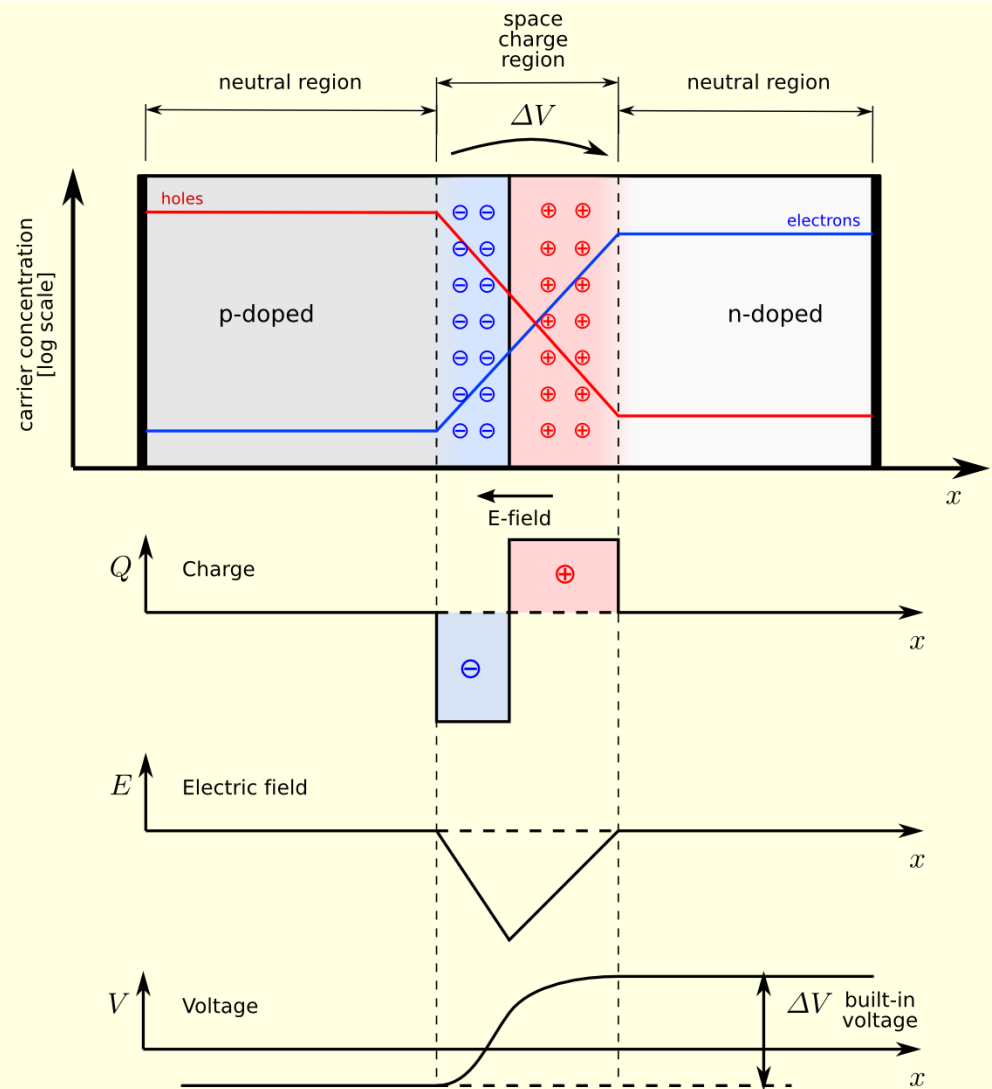

Efect fotovoltaic

- ▶ joncțiunea pn / Fotodioda

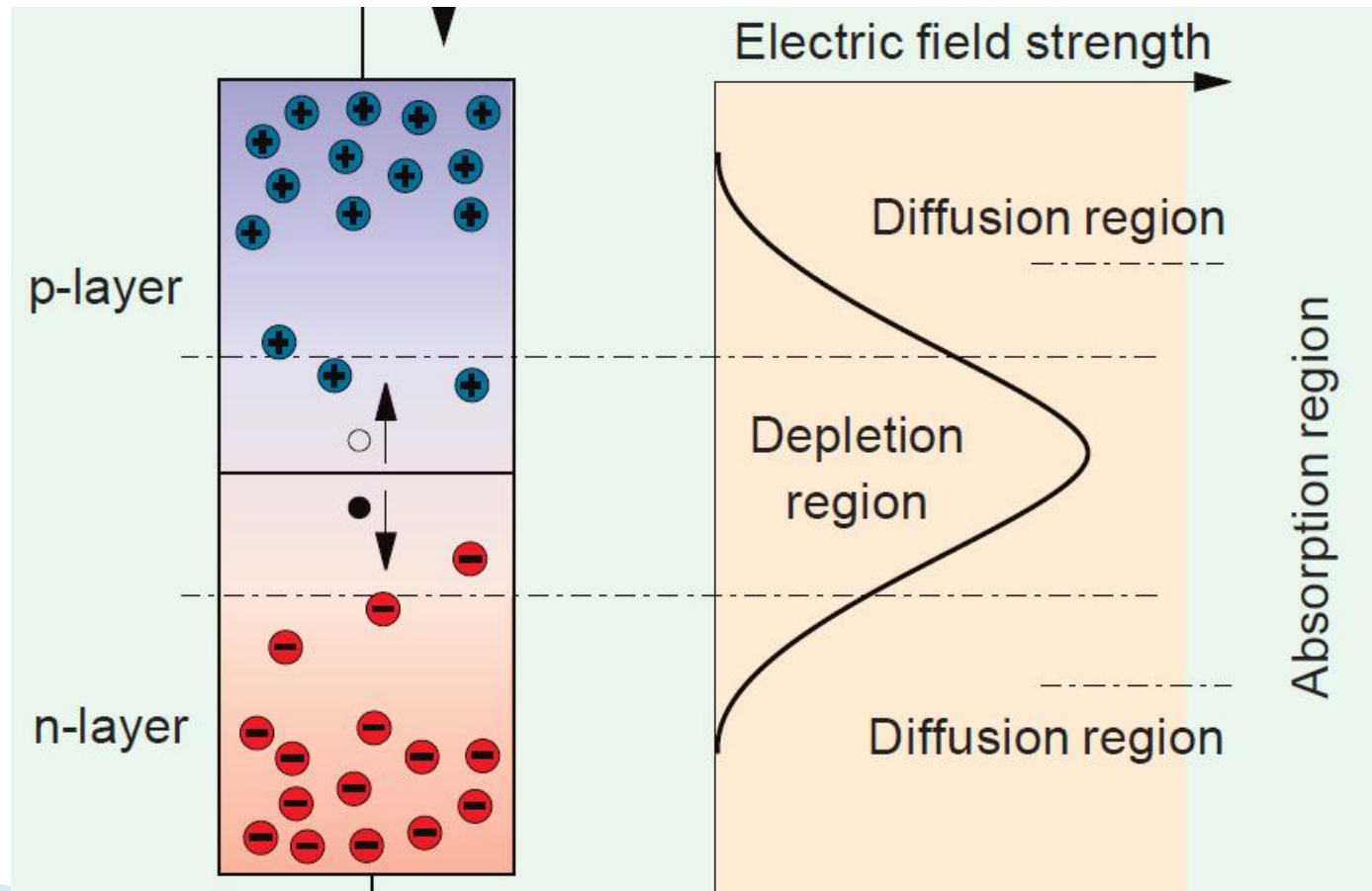

Efect fotovoltaic

- ▶ generarea unei perechi electron/gol in interiorul unui material prin absorbtia energiei fotonilor incidenti si cresterea energiei potentiale a electronilor
 - urmat de posibilitatea separarii sarcinilor
- ▶ deosebit de conversia:
 - fototermica (energia fotonilor este convertita in caldura – energie cinetica a electronilor)
 - fotochimica (fotosinteza energie potentiala utilizata chimic)
- ▶ duce la aparitia unei tensiuni electromotoare si a unui curent intr-un circuit inchis

Efect fotovoltaic

- ▶ diferit de efectul fotoelectric (cu toate ca este asemanator ca principiu)

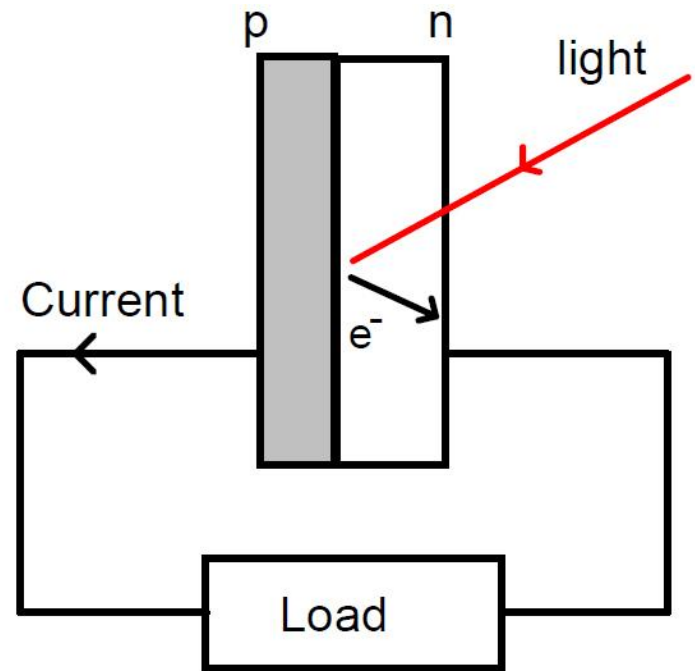
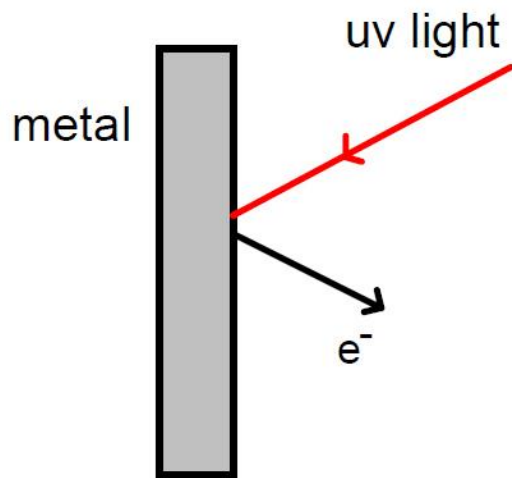

Efect fotovoltaic

- ▶ Separarea fizica a sarcinilor este de obicei realizata prin utilizarea unei jonctiuni pn:
 - campul electric generat de distributia sarcinilor in zona golita de purtatori a jonctiunii
- ▶ In principiu o **celula solara** este o **fotodioda** in care:
 - nivelul de semnal optic este ridicat (fortarea prin polarizare inversa externa a extragerii tuturor electronilor generati nu e necesara)
 - viteza de lucru nu e importanta (accelerarea iesirii din dispozitiv a electronilor generati nu e necesara)

Celula solara (fotovoltaica)

- ▶ in principiu o dioda
 - cu arie mare ($\sim 100\text{cm}^2$)
 - cu suprafata tratata antireflectorizant
 - genereaza o tensiune electromotoare de $0.5\div 1\text{V}$
 - genereaza curenti de scurtcircuit de $x0\text{ mA/cm}^2$

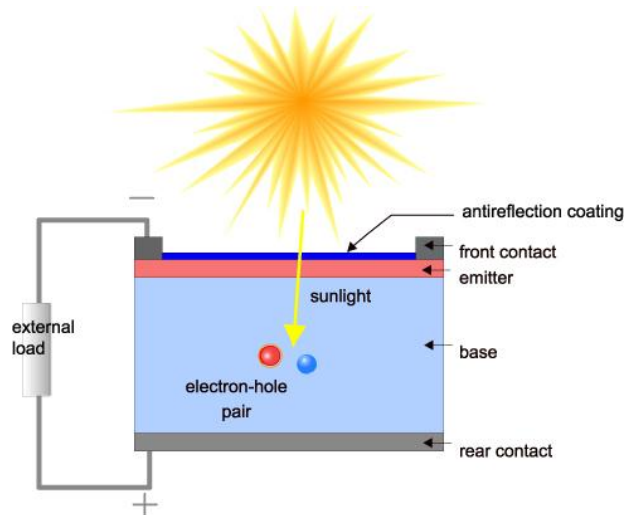

Celula solara (fotovoltaica)

- ▶ pentru utilizare in practica
 - module de 28 – 36 de celule conectate in serie
 - creste tensiunea la 12V (tipic)

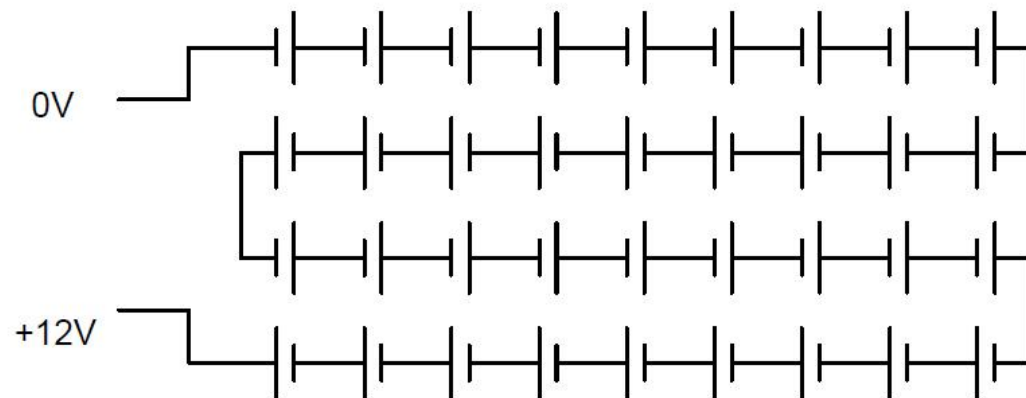
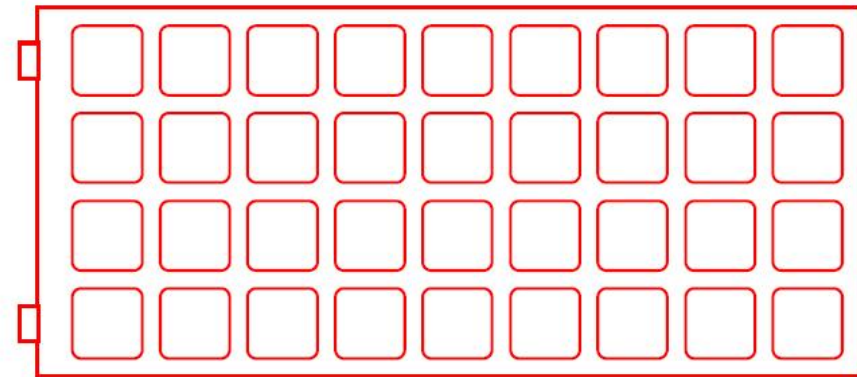

Celula solara (fotovoltaica)

- ▶ pentru utilizare in practica
 - modulele sunt conectate in serie si/sau paralel pentru obtinerea tensiunilor/curentilor necesari pentru aplicatie

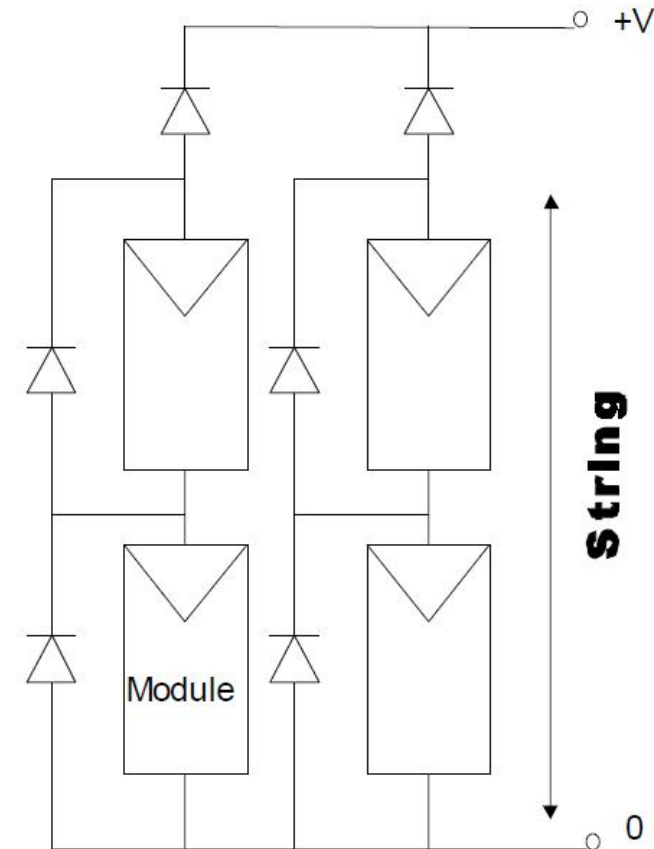
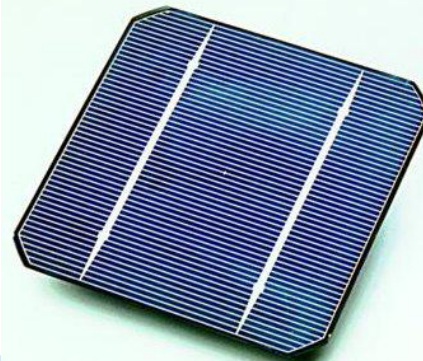
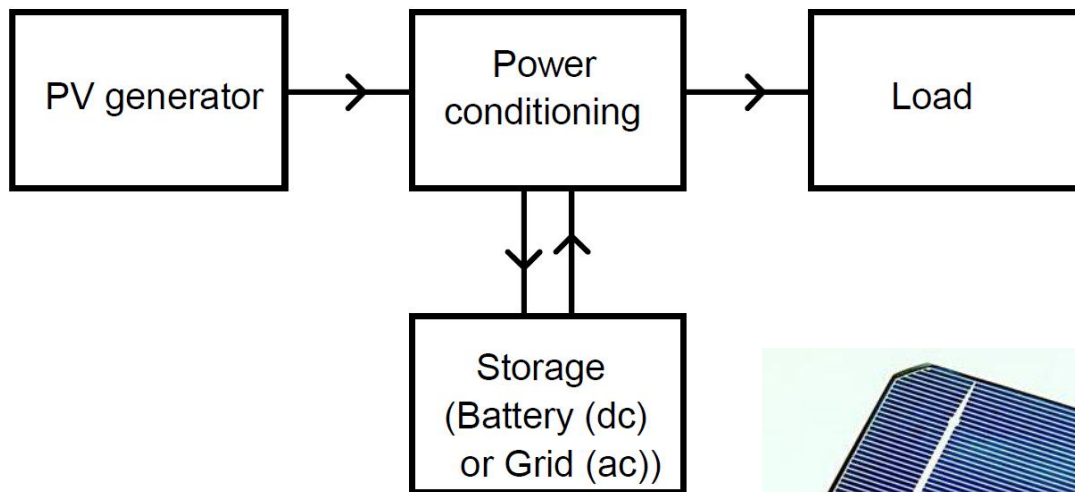

Celula solara (fotovoltaica)

- ▶ pentru utilizare in practica
 - diode pentru flexibilitate

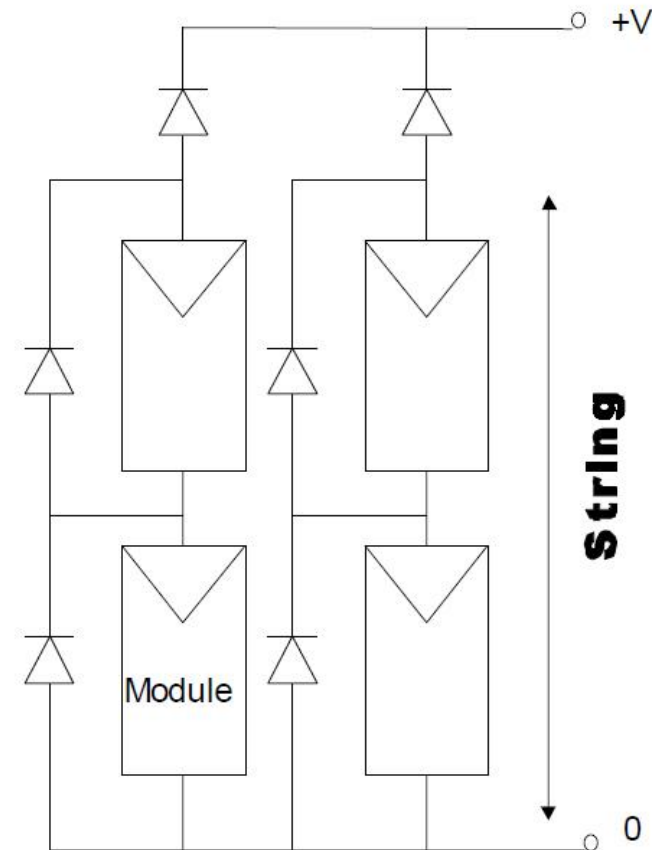
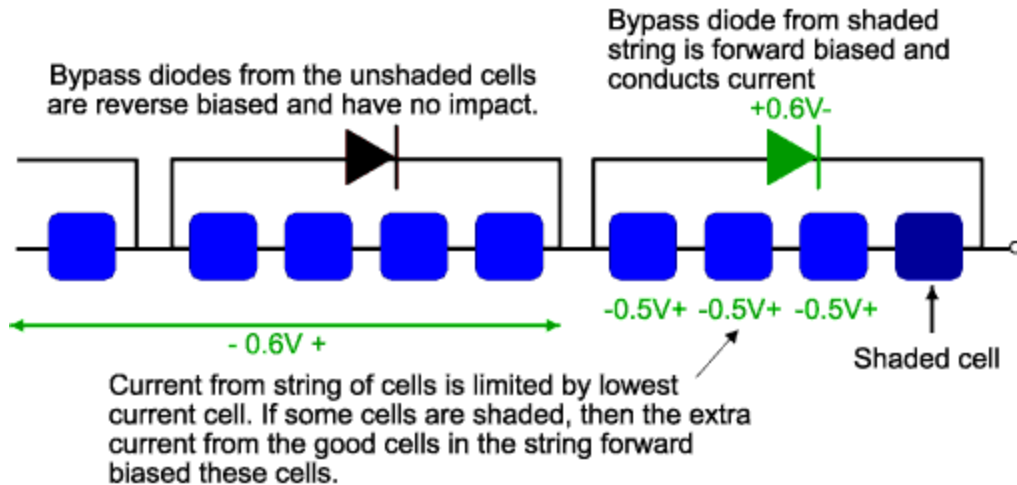

Celula solara (fotovoltaica)

- ▶ in principiu o dioda

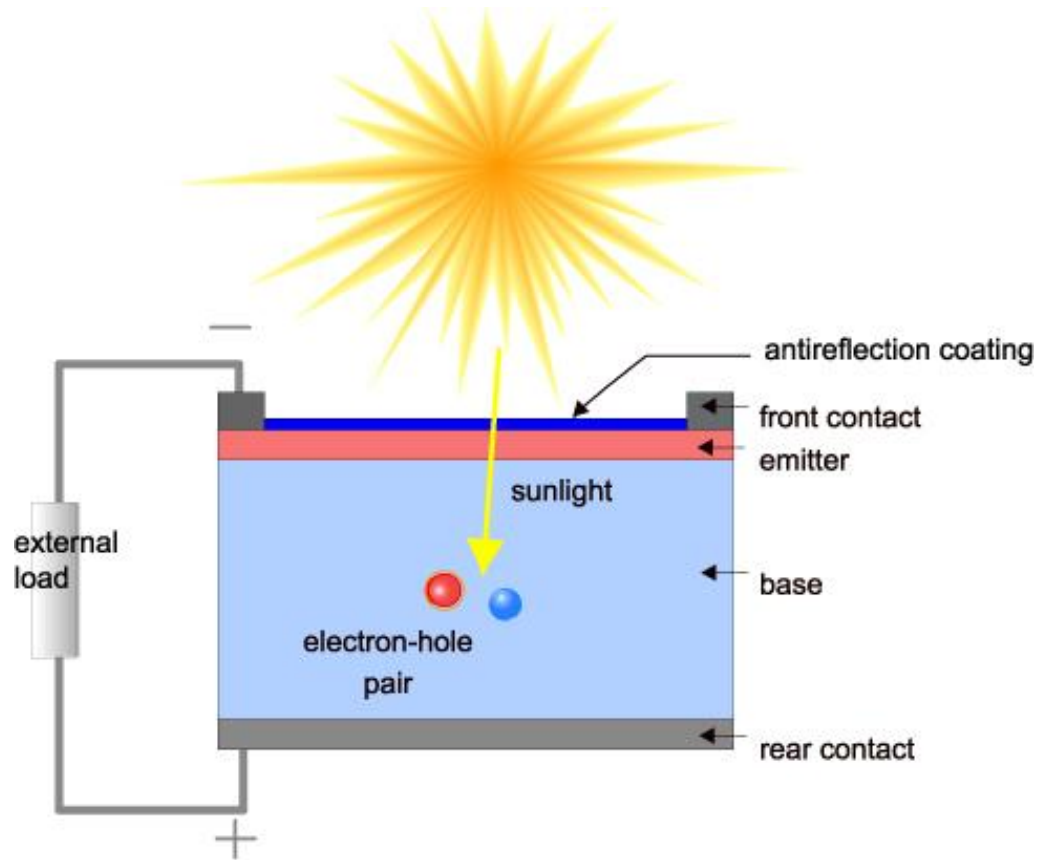

Celula solara

- ▶ probabilitate de generare a purtatorilor depinde de
 - **material**
 - distanta parcursa

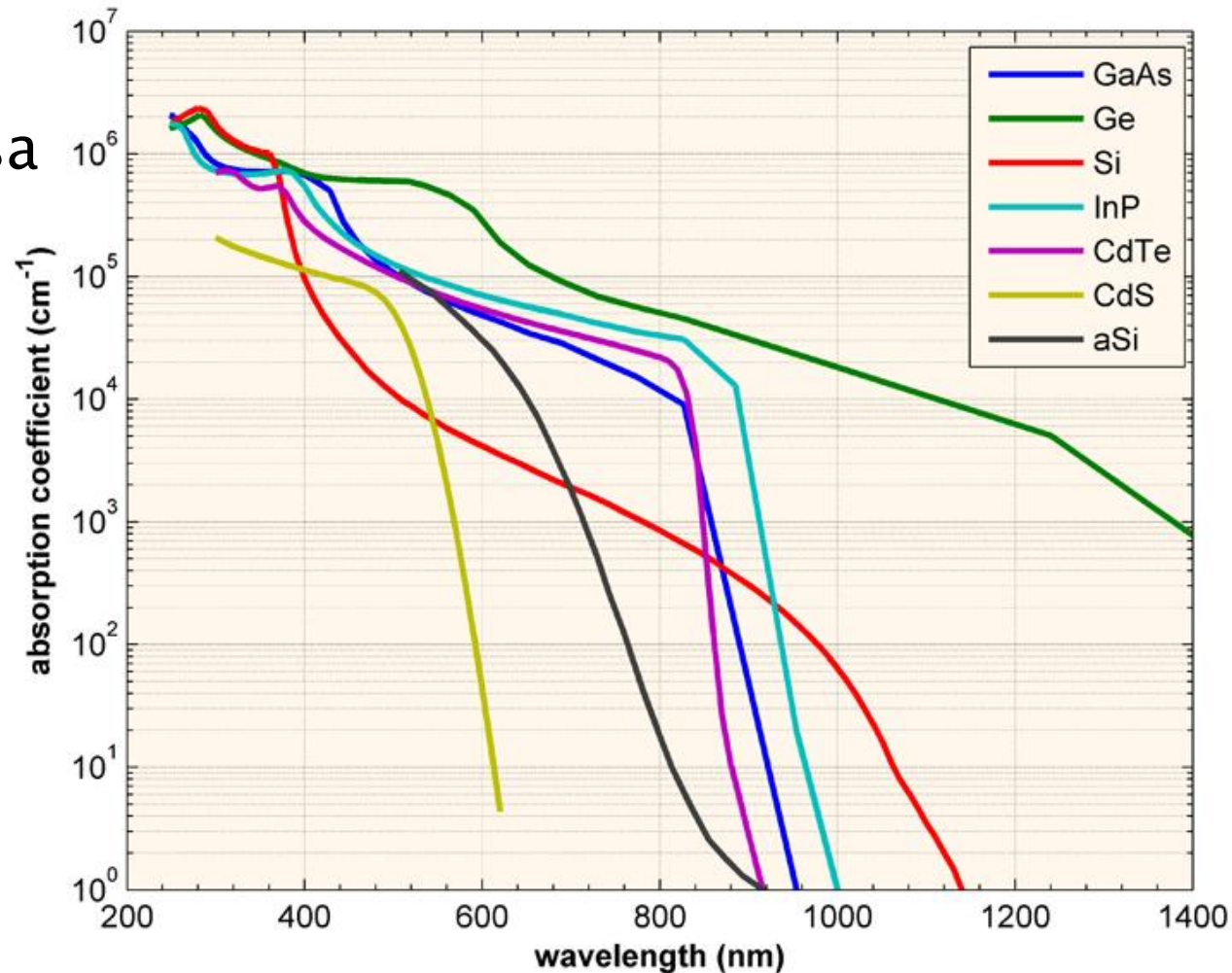

Celula solara

- ▶ probabilitate de generare a purtatorilor depinde de
 - material
 - **distanța parcursă**

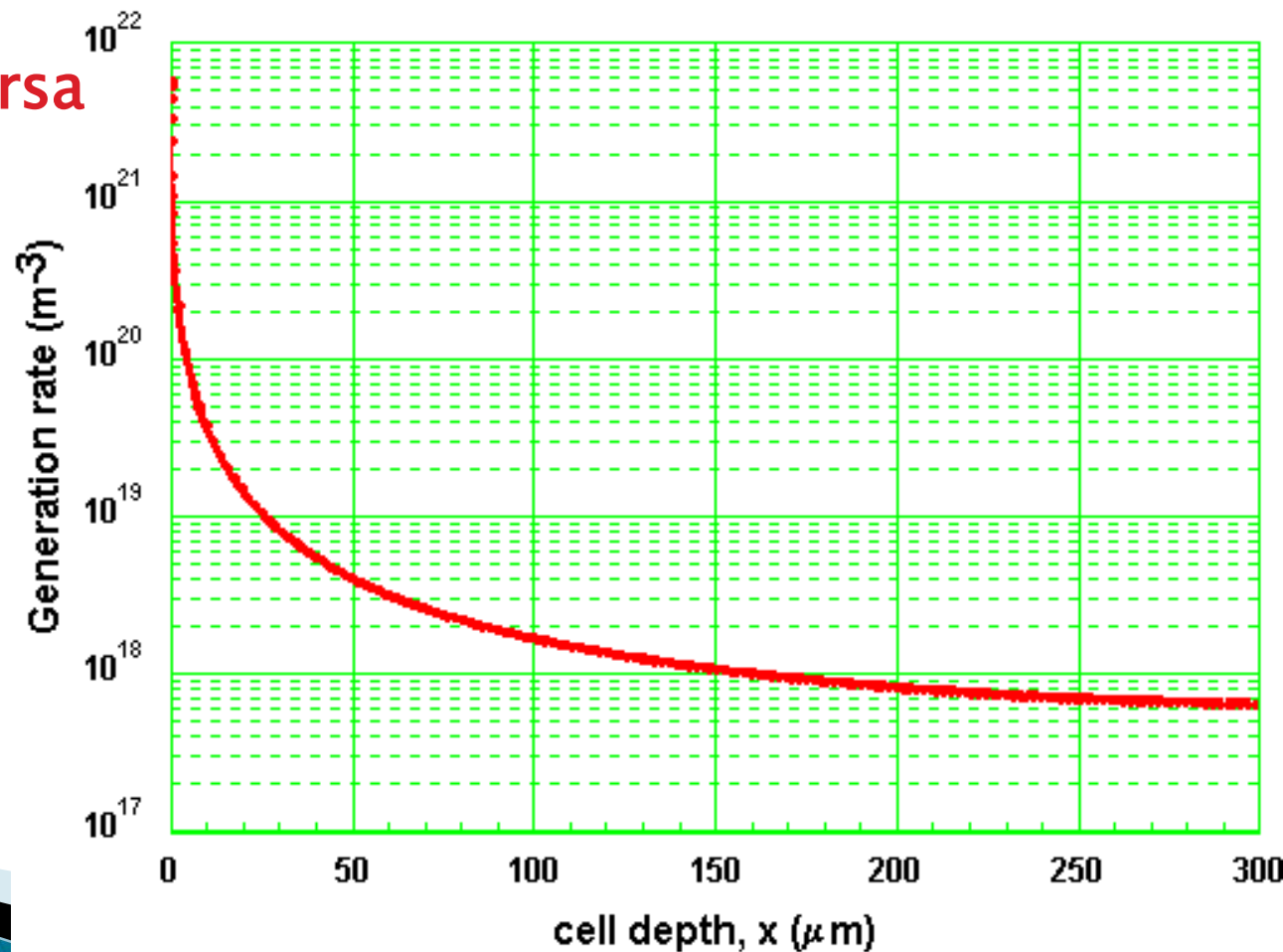

Celula solara

- ▶ probabilitate de captura a purtatorilor

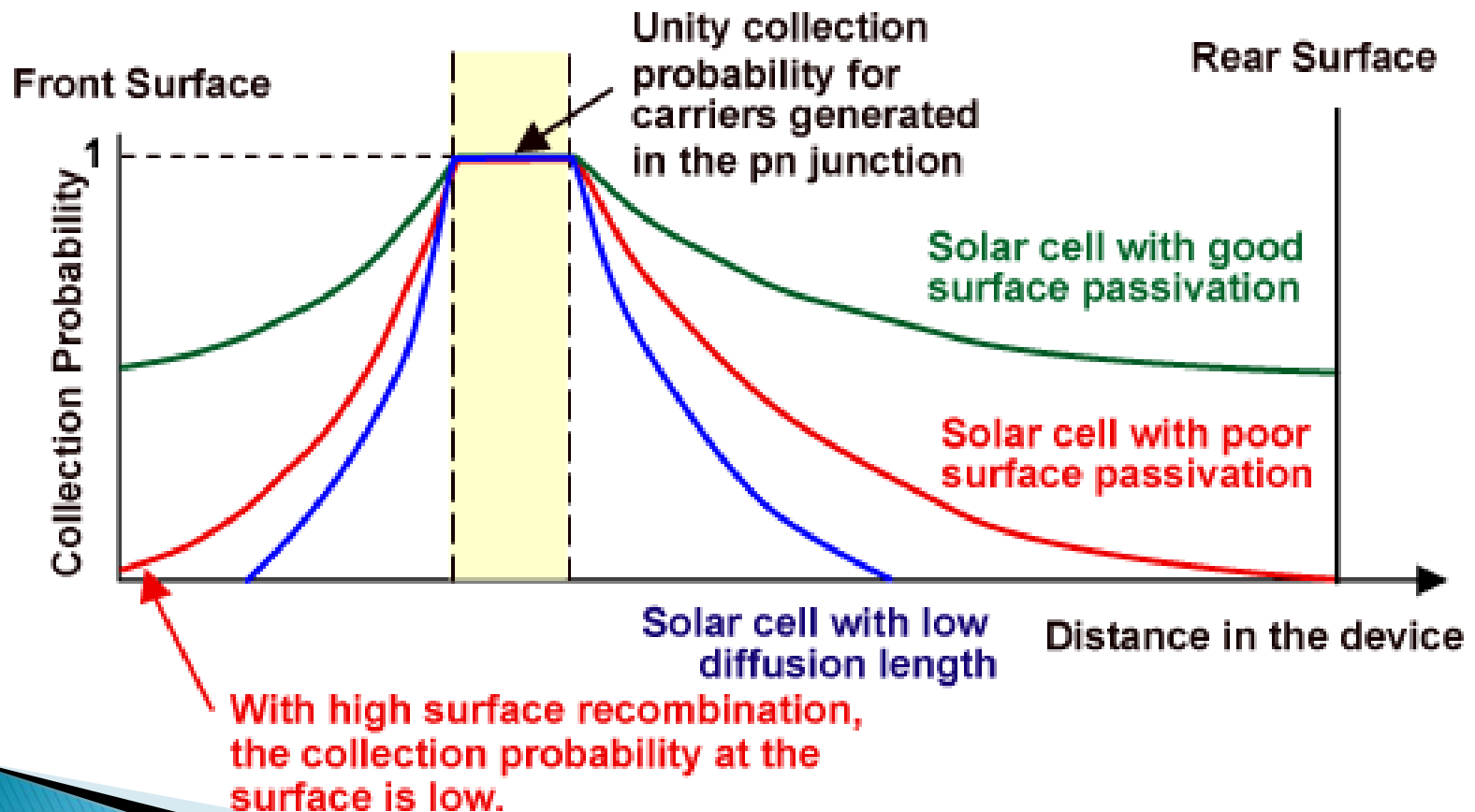

Celula solara/Fotodioda

- ▶ Energia necesara pentru eliberarea unei perechi electron gol

$$h\nu = \frac{hc}{\lambda} \geq E_g$$

- ▶ Lungime de unda de taiere

$$\lambda_{\max} = \frac{hc}{E_g}$$

- ▶ Coeficientul de absorbtie are valoare mare la lungimi de unda reduse
- ▶ Ca urmare comportarea **tuturor** materialelor este de tip trece banda

Celula solara

- ▶ raspuns spectral

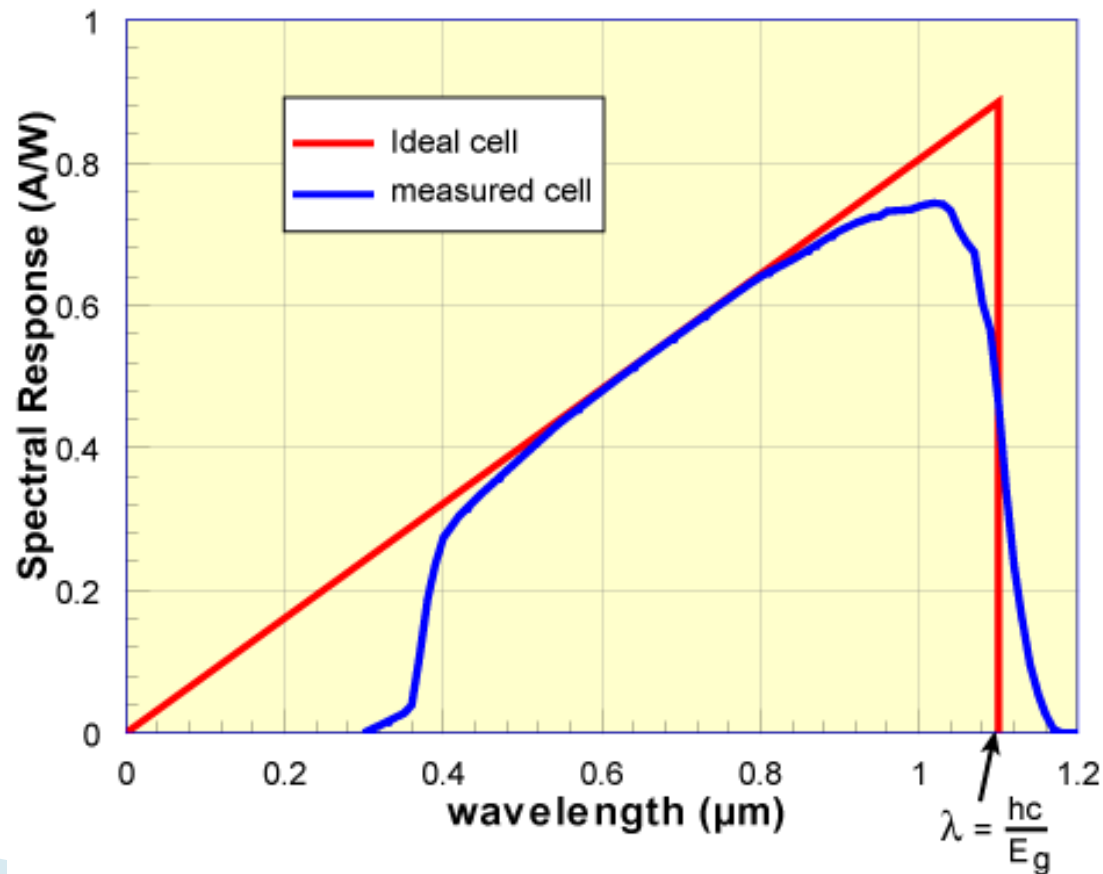

Celula solara

- ▶ Schema echivalenta

- dioda
- sursa de curent generat de fluxul de fotoni incident

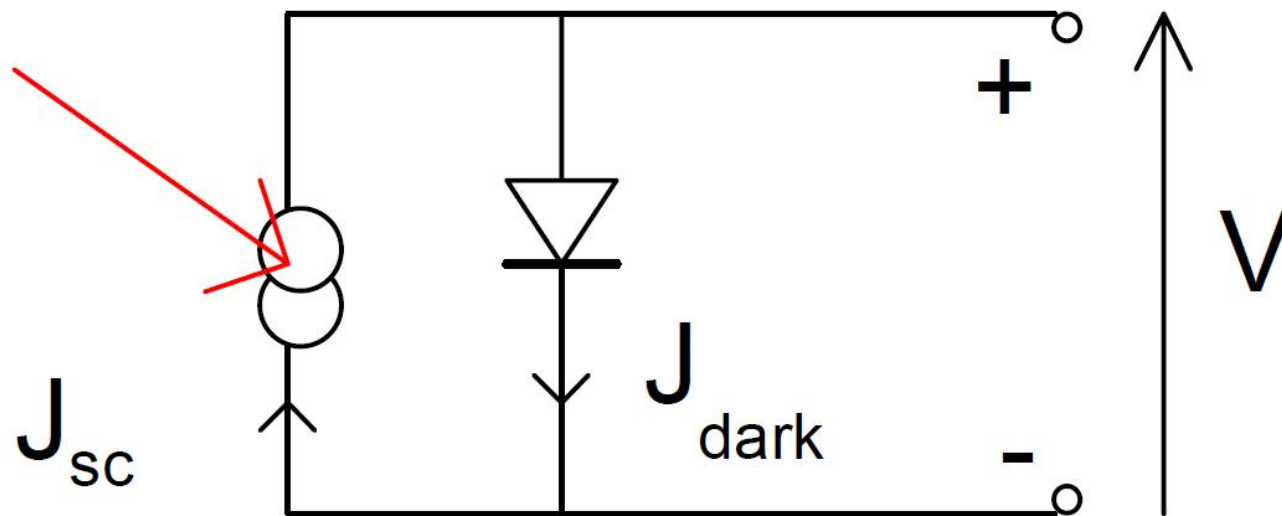

Celula solara

▶ Schema echivalenta

- dioda
- sursa de curent generat de iluminarea energetica incidenta

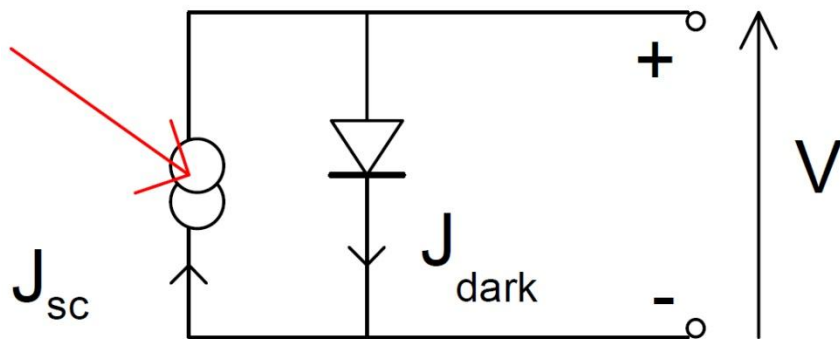

- curent de intuneric

$$I_d(V) = I_0 \cdot (e^{eV/KT} - 1)$$

- adaugarea curentului generat de fotoni

$$I(E_e, V) = I_{sc}(E_e) - I_d(V)$$

- tensiunea in gol

$$V_{oc} = \frac{k \cdot T}{e} \cdot \ln \left(\frac{I_{sc}(E_e)}{I_0} - 1 \right)$$

Celula solara

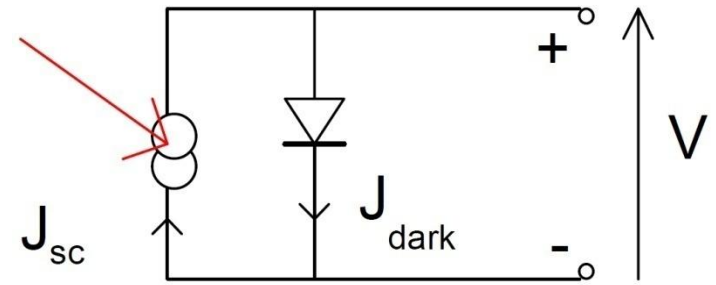

$$I(E_e, V) = I_{sc}(E_e) - I_d(V)$$

J_{sc}

Light current

Dark current

$$I_d(V) = I_0 \cdot (e^{eV/KT} - 1)$$

V_{oc}

Bias voltage, V

$$V_{oc} = \frac{k \cdot T}{e} \cdot \ln \left(\frac{I_{sc}(E_e)}{I_0} - 1 \right)$$

Celula solara

- ▶ poate fi folosita in loc de baterie intr-un circuit electric
 - cu anumite diferente

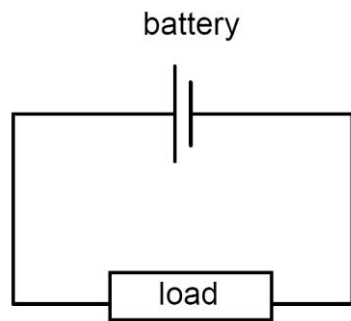

solar cell

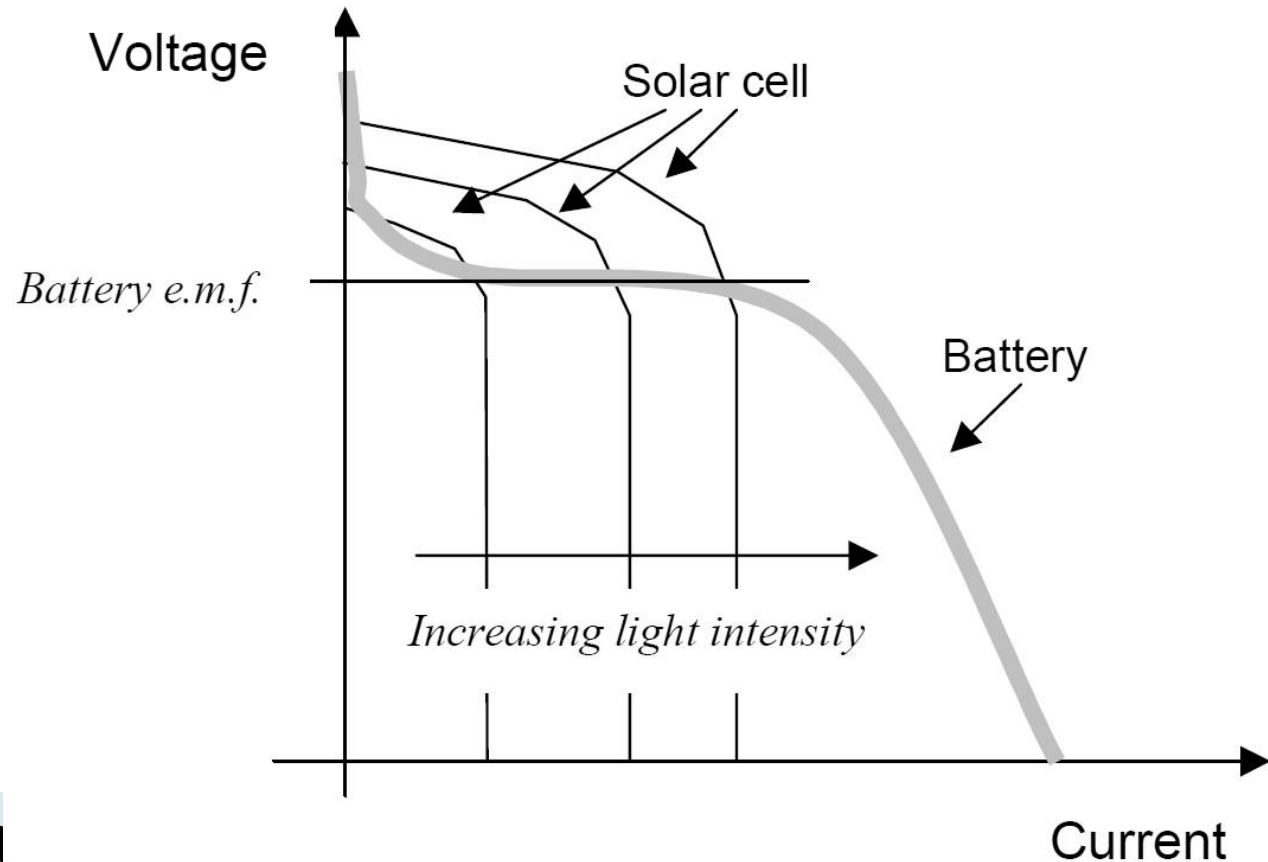
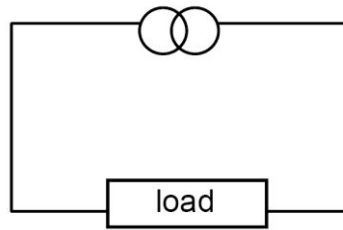

Celula solara

- ▶ Putere generata

$$P = V \cdot I$$

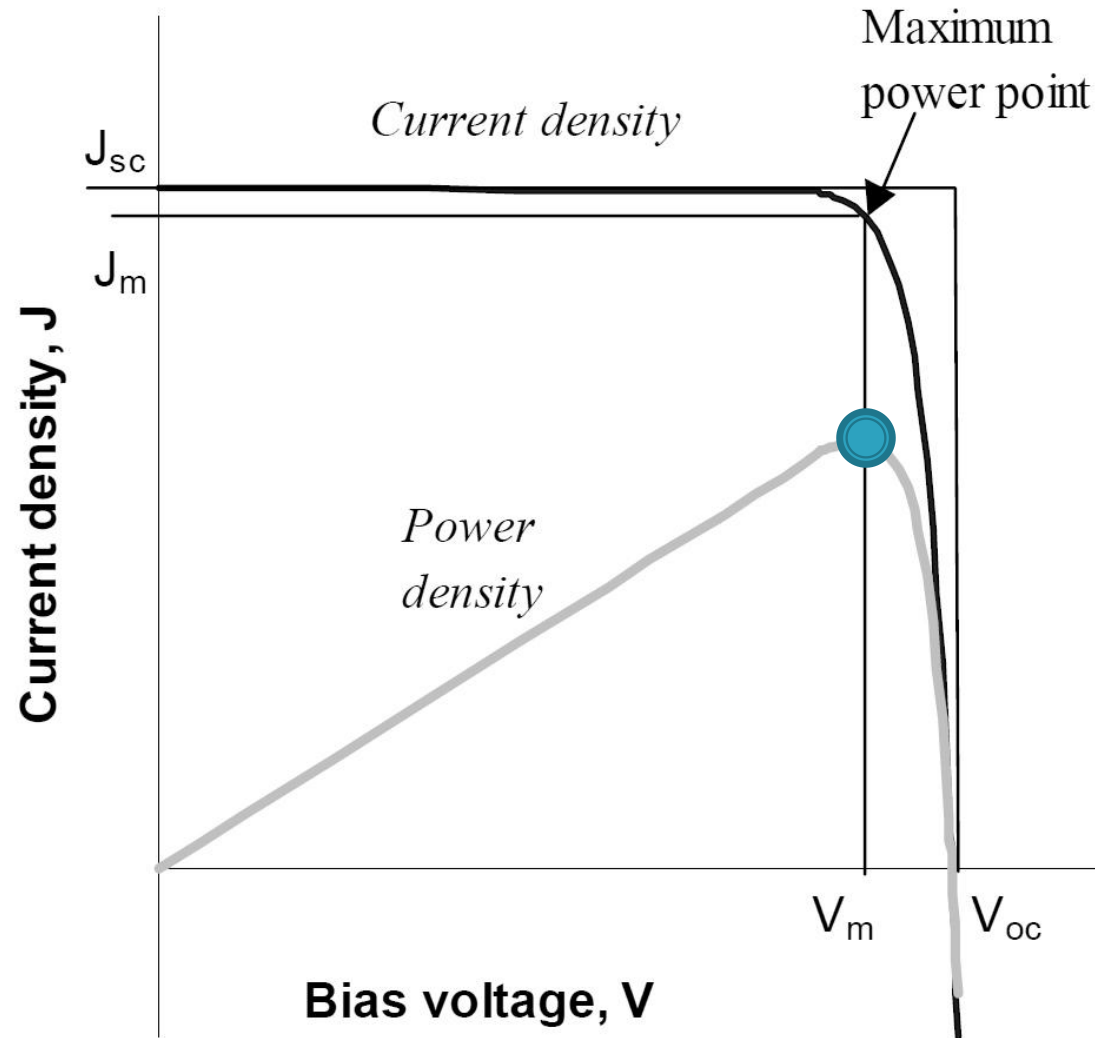
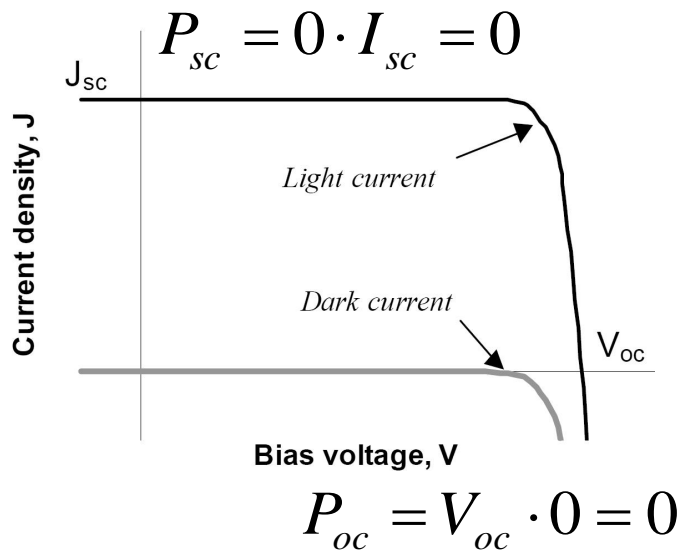

Celula solara

▶ Putere generata

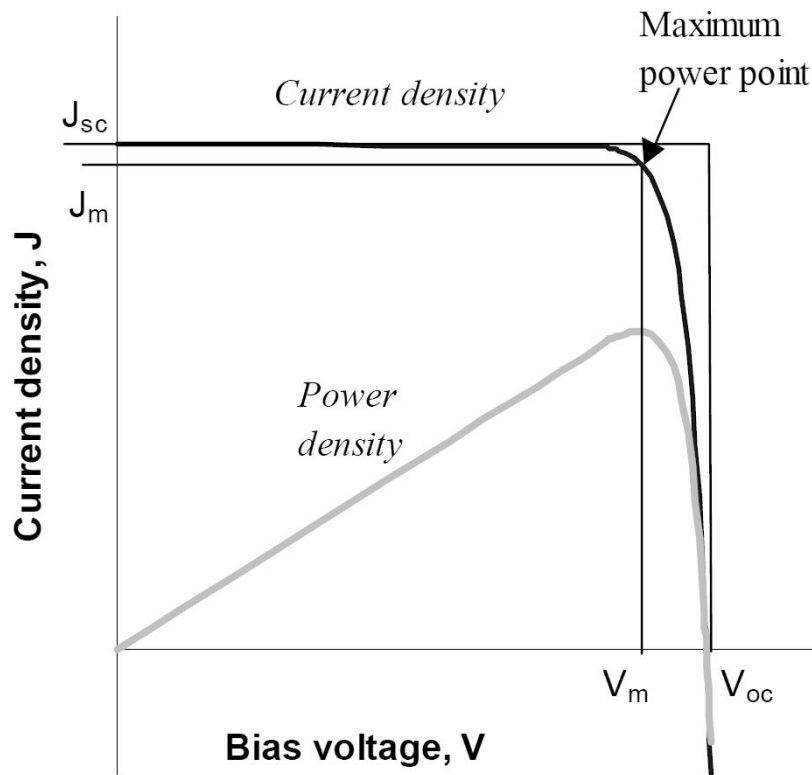

$$P_m = V_{pm} \cdot I_{pm}$$

- ▶ Valorile de curent si tensiune pentru putere maxima sunt date de catalog, circuitul de conditionare care urmeaza dupa celule poate fi **optimizat** sa functioneze la aceste valori

Celula solara

- ▶ Factor de umplere

$$FF = \frac{V_{pm} \cdot I_{pm}}{V_{oc} \cdot I_{sc}}$$

- ▶ o masura a calitatii celulei
 - dependent de material

$$P_m = V_{pm} \cdot I_{pm}$$

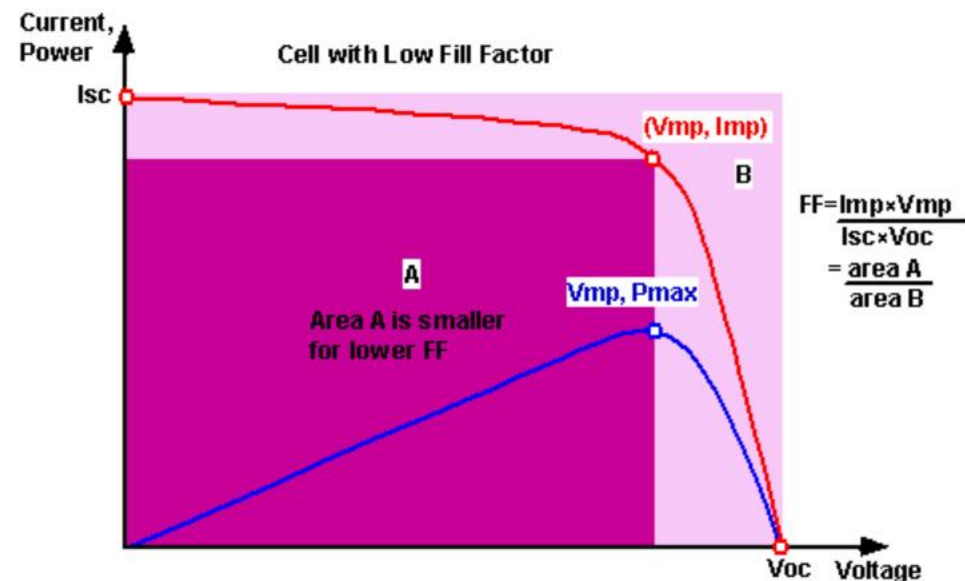
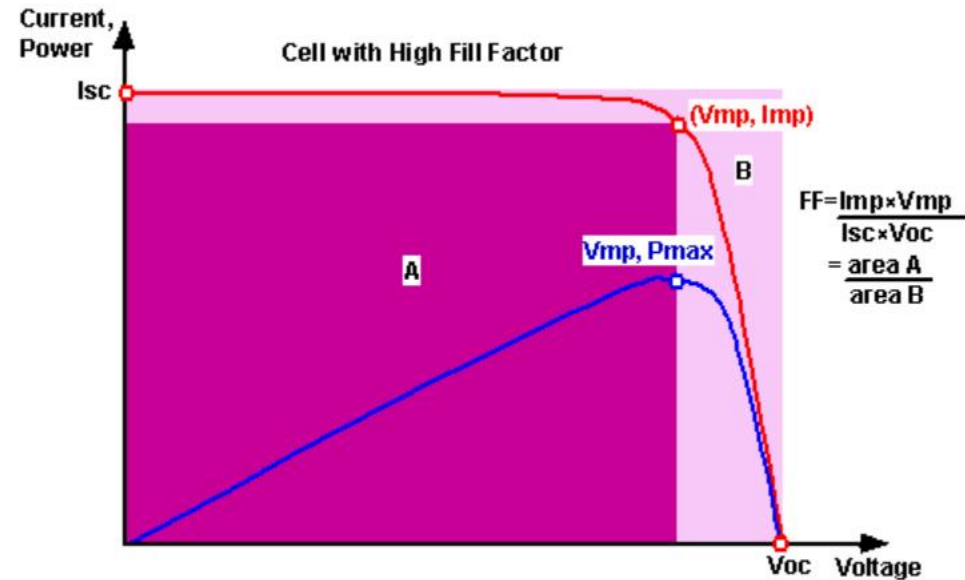
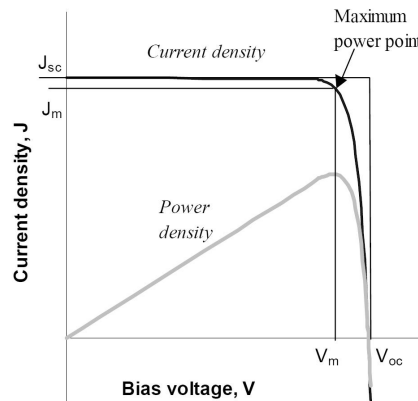

Efect pierderi

- ▶ Rezistenta serie
 - rezistenta echivalenta a semiconductorului utilizat
 - rezistenta jonctiunilor metal/semiconductor
 - rezistenta contactului metalic al anodului si colectorului
- ▶ Rezistenta paralel
 - generata de defecte de fabricatie

Efect pierderi

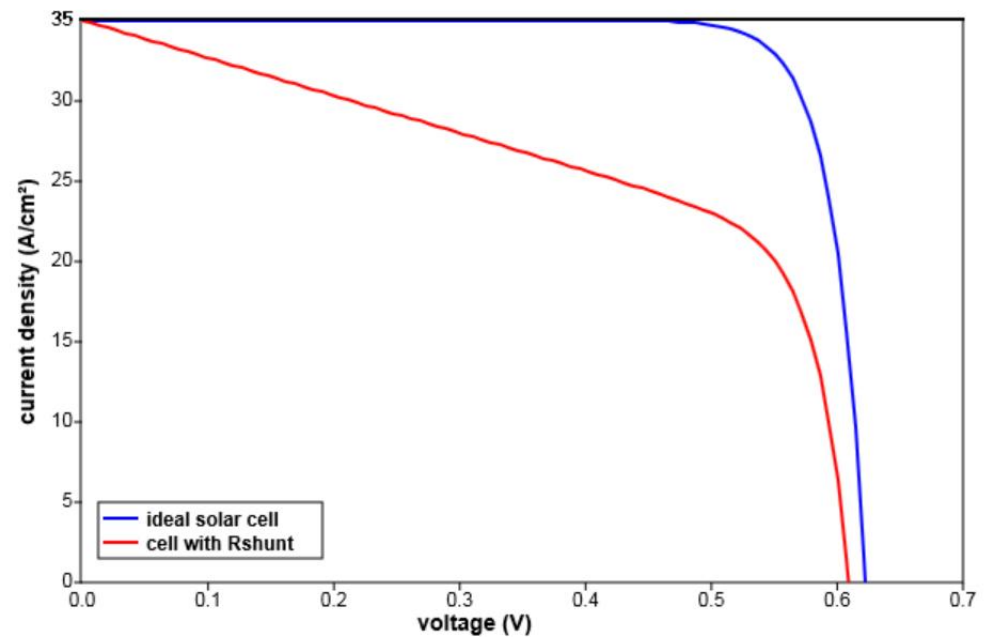
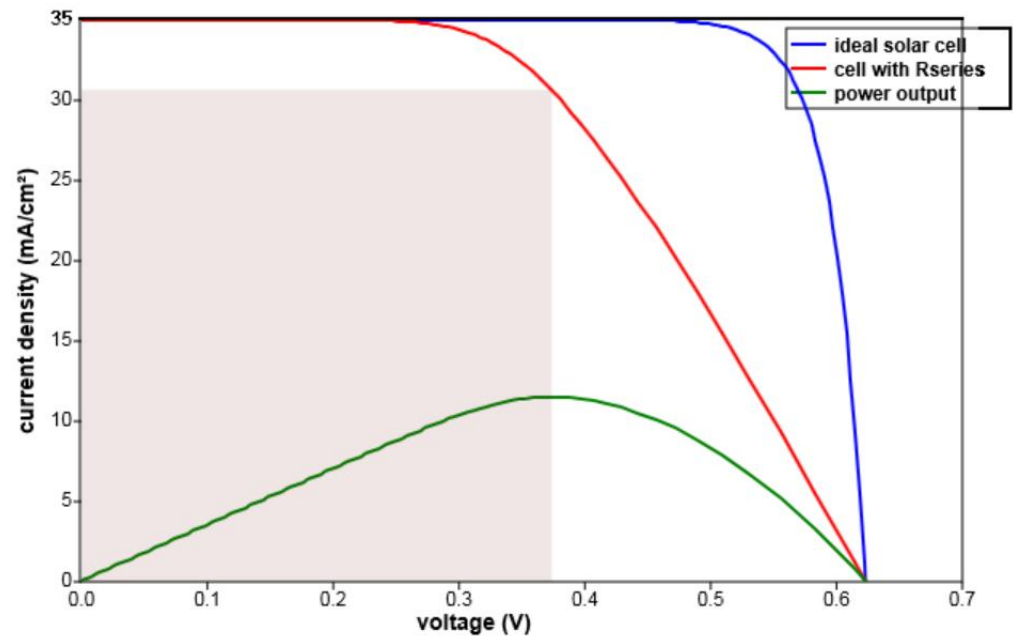
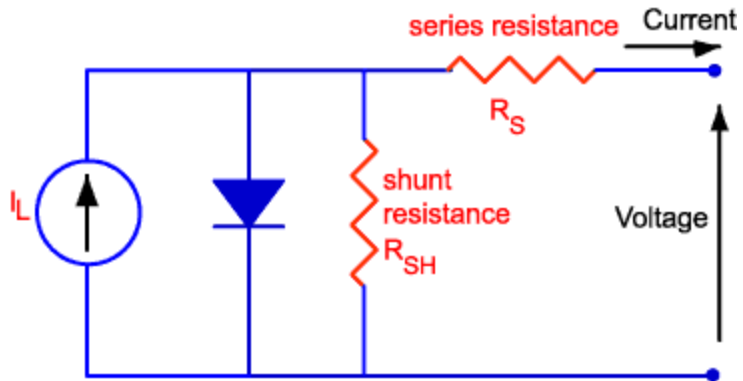

Rezistenta serie

- ▶ Minimizare R_s
 - bare colectoare
 - “degete”
- ▶ Compromis
 - rezistenta
 - suprafata metalica reflectorizanta

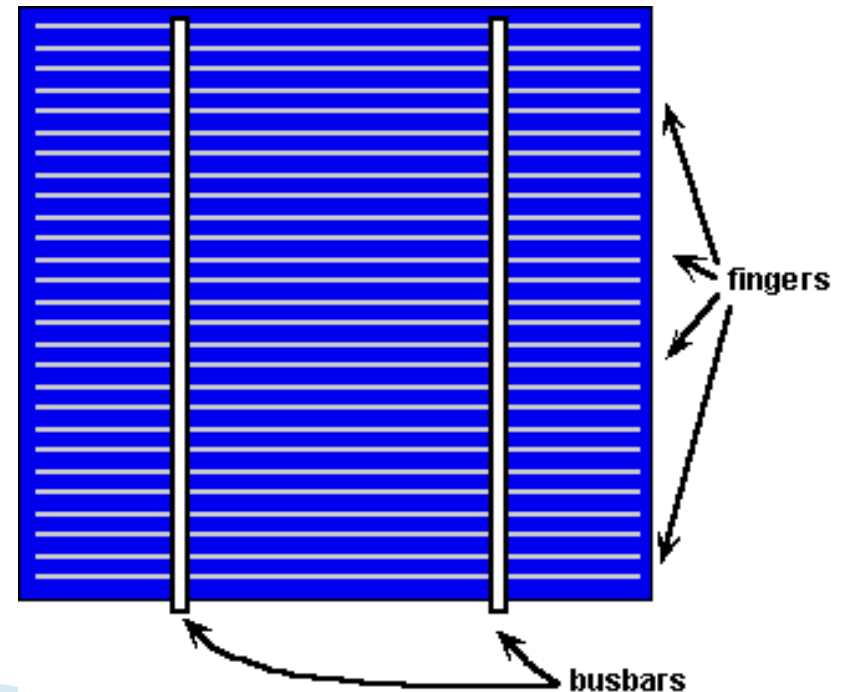
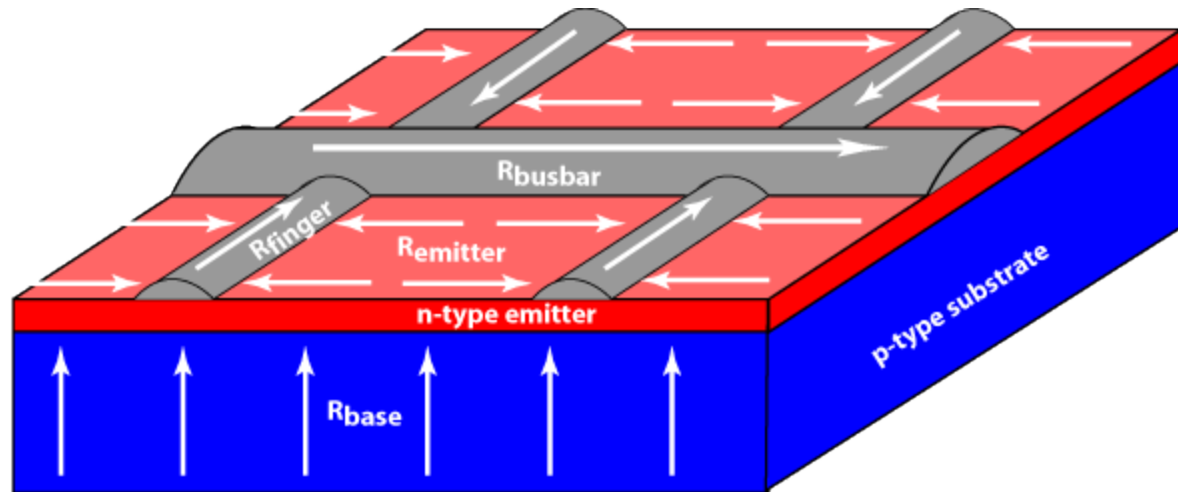

Rezistenta serie

- ▶ Comprimis rezistenta/suprafata metalica

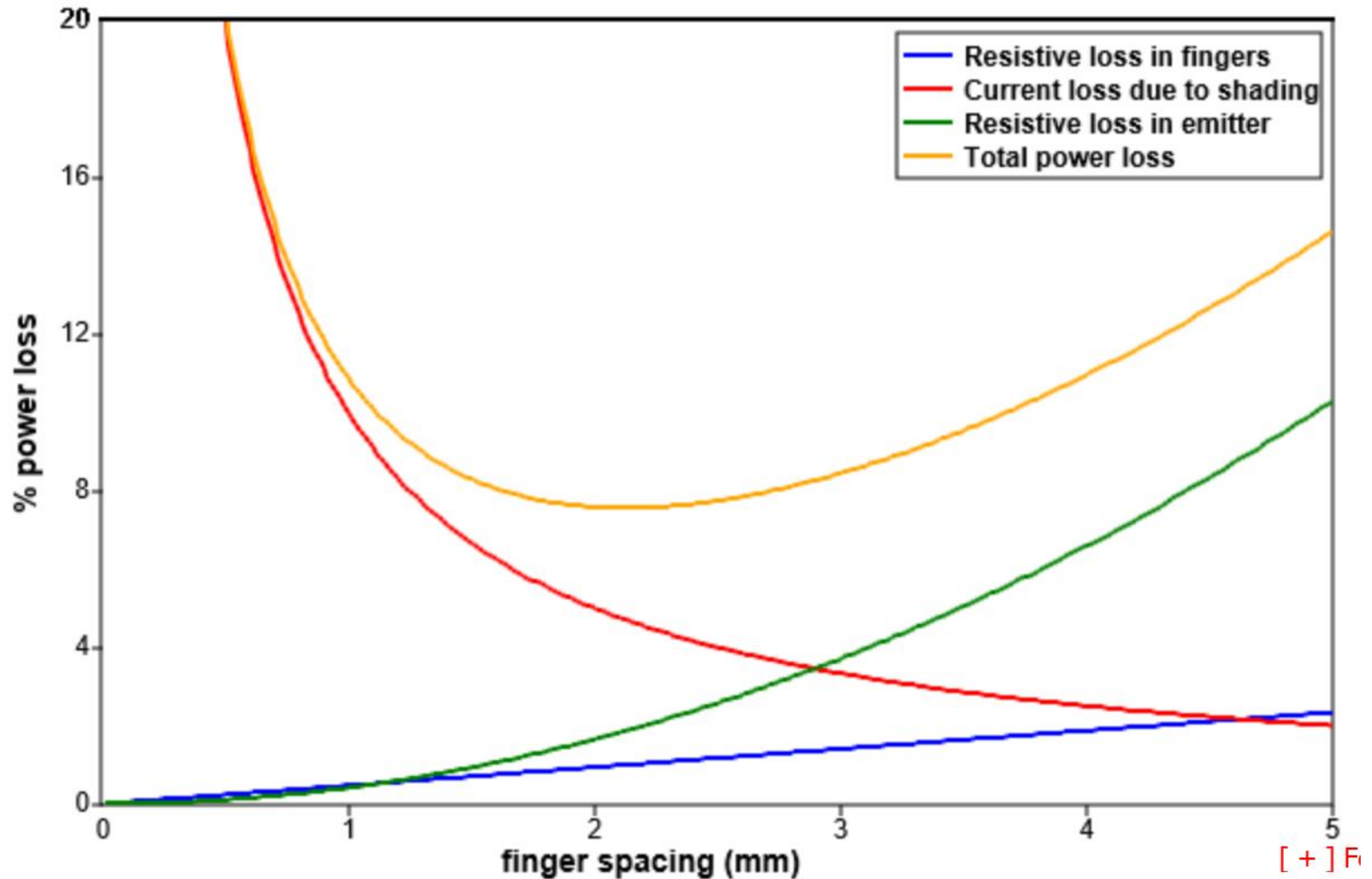

Rezistenta caracteristica

- ▶ Raportul intre V si I cand celula lucreaza la eficienta maxima

$$R_C = \frac{V_{pm}}{I_{pm}} \approx \frac{V_{OC}}{I_{SC}}$$

- ▶ Daca sarcina este egala cu R_C , celula lucreaza la eficienta maxima

- ▶ Tipic, celulele comerciale opereaza la tensiune mica si curent mare
 - ▶ conexiunile la celule trebuie sa aiba rezistente de ordinul $m\Omega$

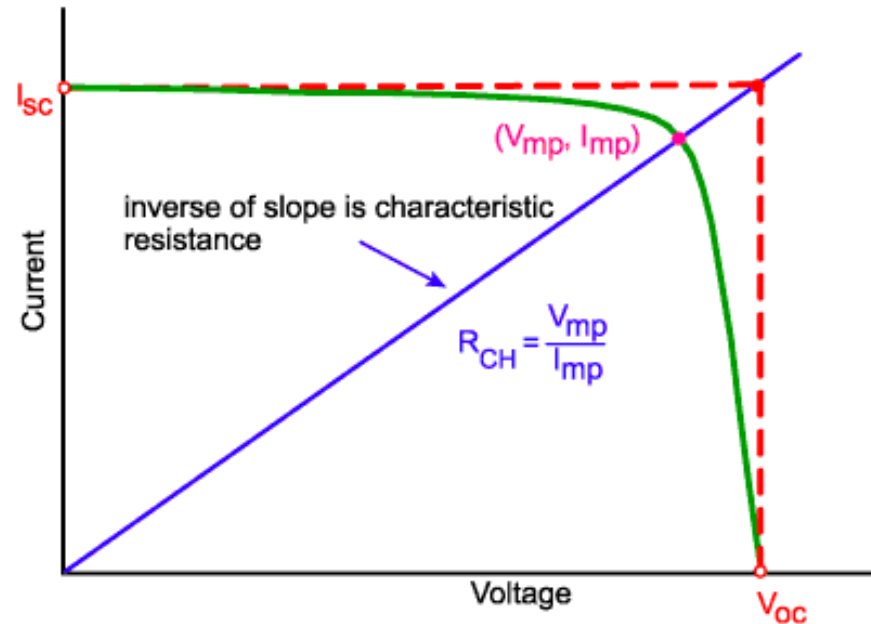

$$R_C = \frac{0.6V}{9A} \approx 0.067\Omega$$

Eficiența celulei solare

- ▶ raportul dintre puterea electrică generată și puterea optică incidentă

$$\eta = \frac{P_m}{P_o} = \frac{V_{pm} \cdot I_{pm}}{P_o}$$

$$\eta = \frac{P_m}{P_o} = \frac{V_{oc} \cdot I_{sc} \cdot FF}{P_o}$$

- ▶ Puterea optică depinde de fluxul energetic al luminii incidente și suprafața celulei

$$P_o = S \cdot \int_0^{\infty} \Phi_e(\lambda) d\lambda$$

Eficiența celulei solare

- ▶ determina suprafața necesară pentru obținerea unei puteri dorite

100% efficiency
(impossible to achieve)



20% efficiency
(monocrystalline silicon solar cells)

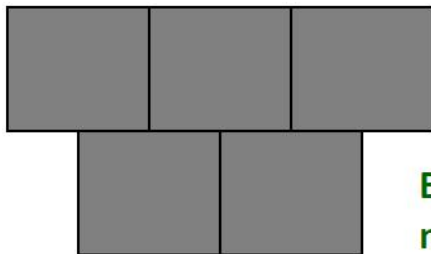

Expensive material

33% efficiency
(space-grade solar cells)

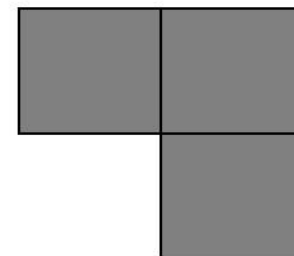

Very Expensive material

10% efficiency
(thin film material)

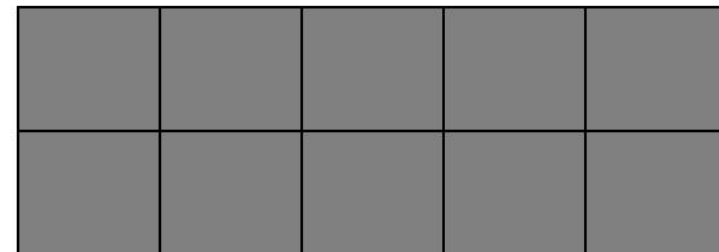

Relatively Inexpensive material

Eficiența celulei solare

- ▶ Exista o limita maxima teoretica pentru fiecare material semiconductor
 - fiecare material are o banda spectrala proprie, **mai mica** decat banda spectrala a soarelui
- ▶ valorile nu sunt foarte mari
 - din motive economice, recordurile nu sunt repetate in practica

Table 1.1. Performance of some types of PV cell [Green *et al.*, 2001].

Cell Type	Area (cm ²)	V _{oc} (V)	J _{sc} (mA/cm ²)	FF	Efficiency (%)
crystalline Si	4.0	0.706	42.2	82.8	24.7
crystalline GaAs	3.9	1.022	28.2	87.1	25.1
poly-Si	1.1	0.654	38.1	79.5	19.8
a-Si	1.0	0.887	19.4	74.1	12.7
CuInGaSe ₂	1.0	0.669	35.7	77.0	18.4
CdTe	1.1	0.848	25.9	74.5	16.4

Eficiența maximă a celulei solare

Best Research-Cell Efficiencies

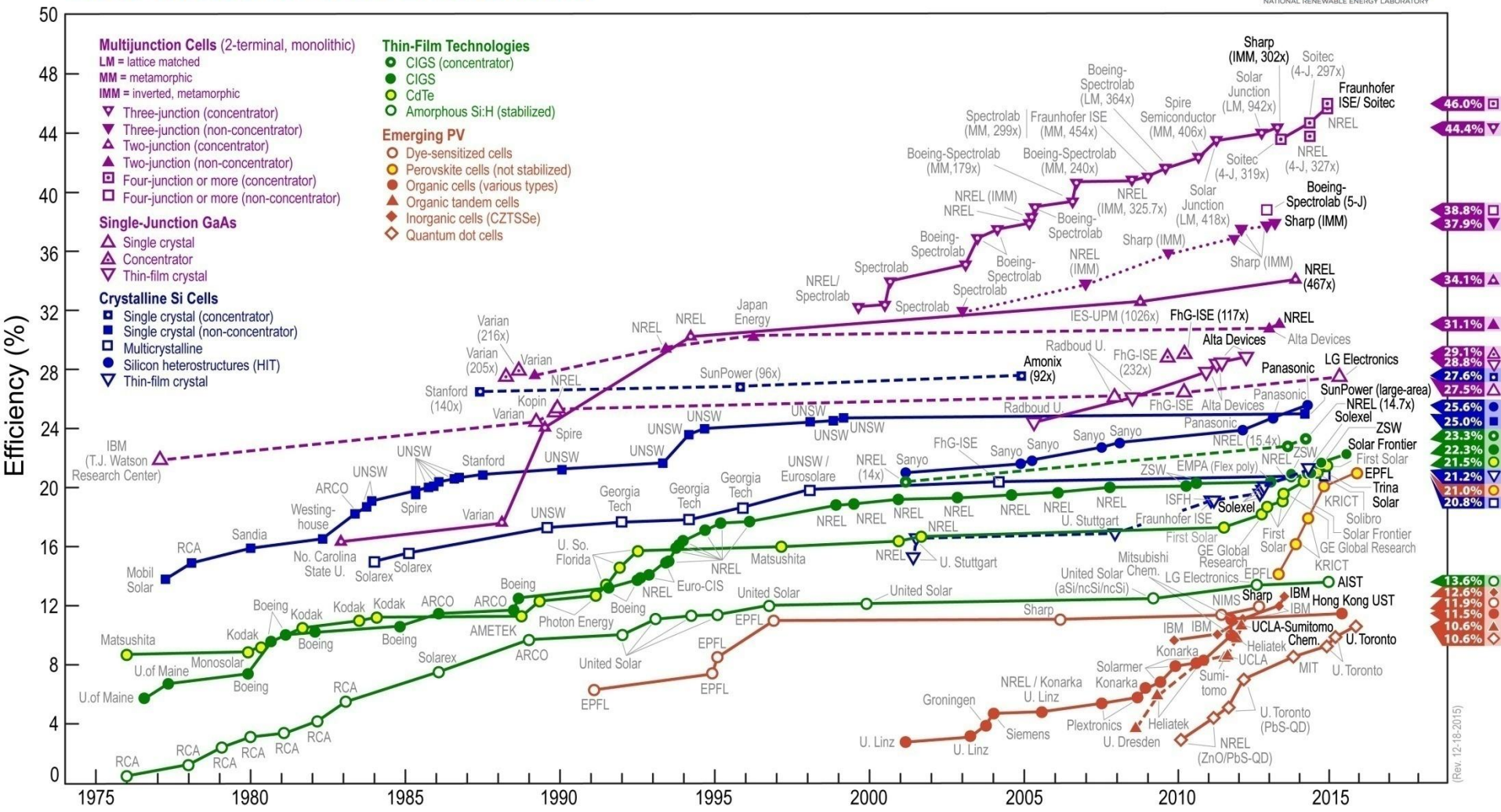

Dependenta de material

- ▶ materialele care ofera tensiuni mari au de obicei curenti mai mici
 - dependent de latimea benzii interzise

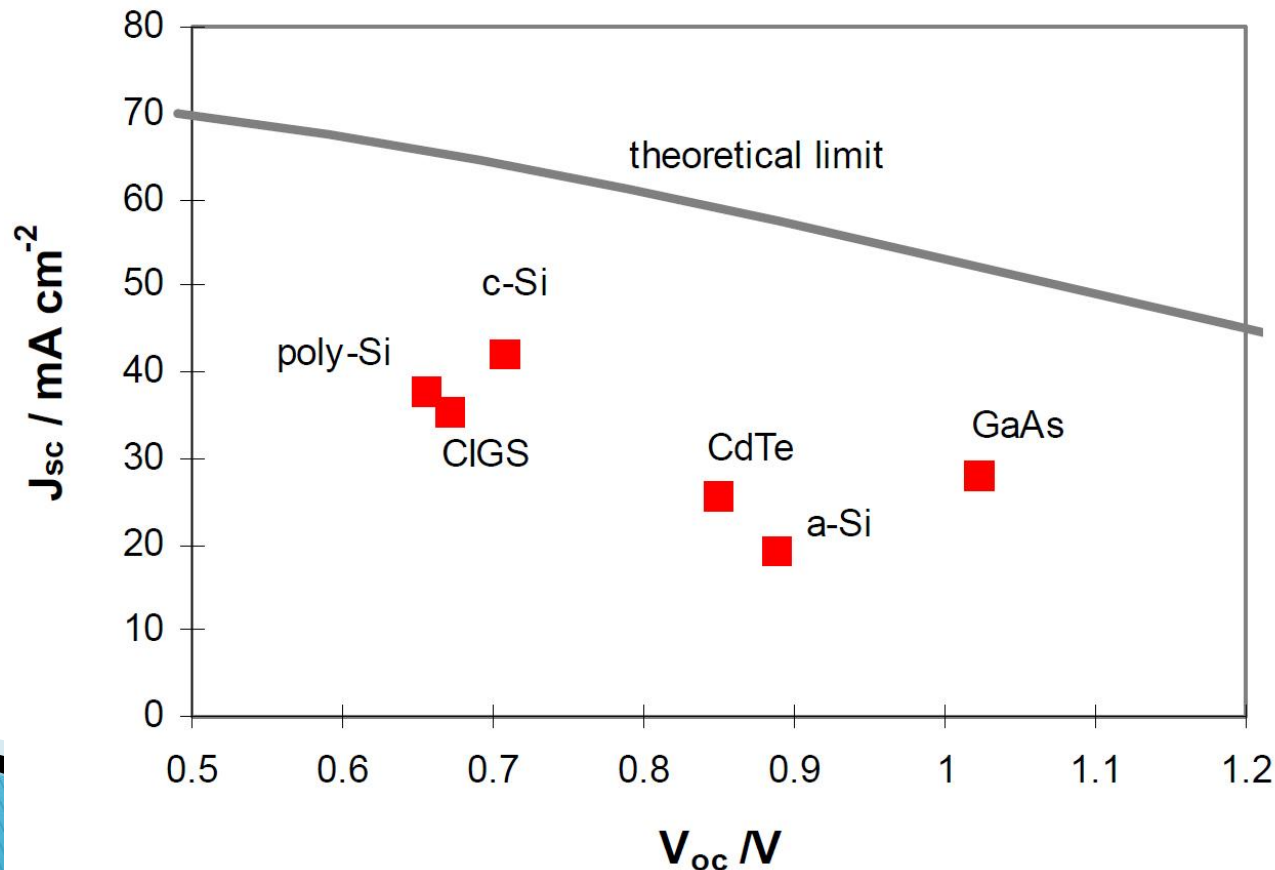

Realizari practice

- ▶ materialul preferat este Si

Global Market Share by PV Technology
from 1990 to 2013

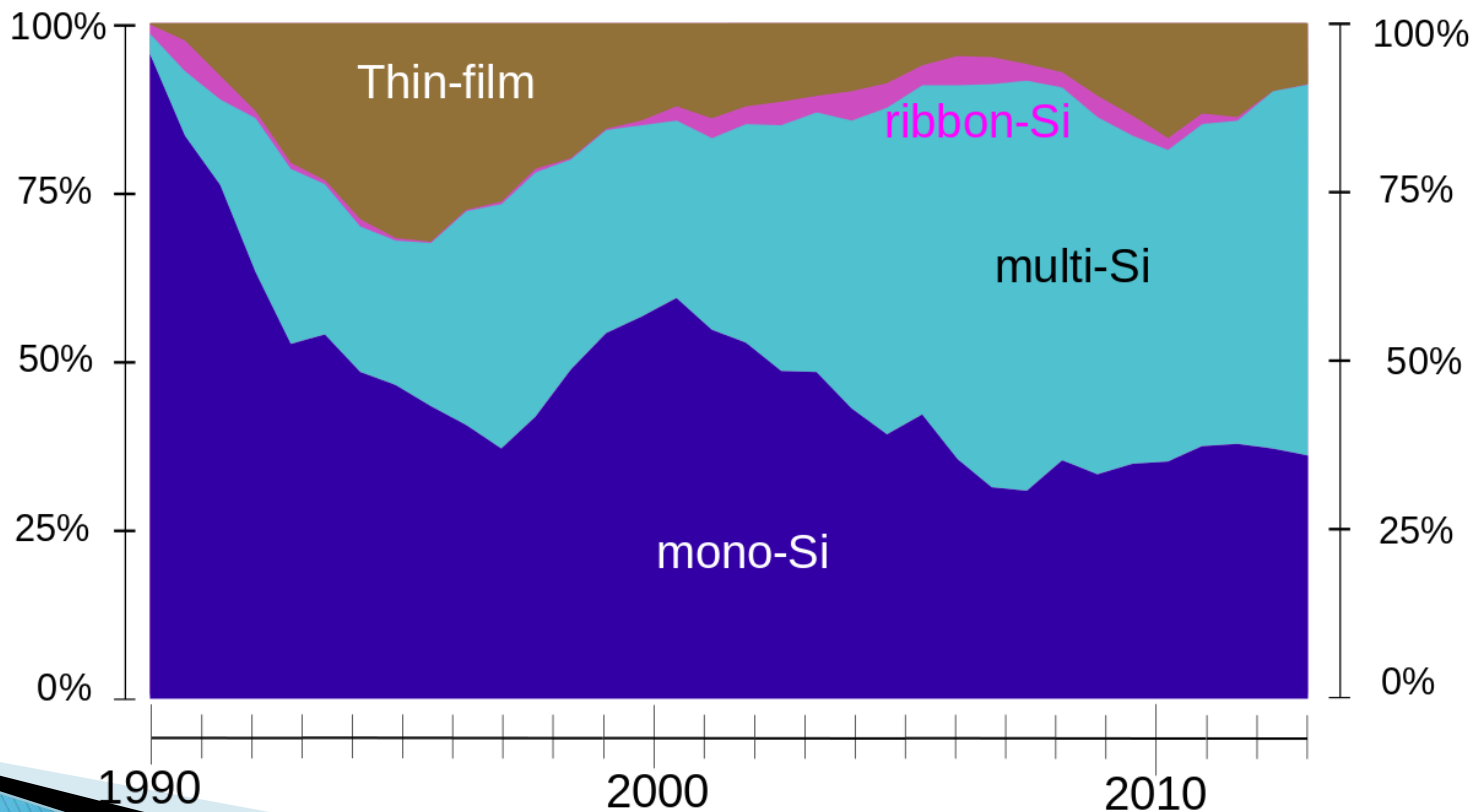

Tipic

80 WATT

POWERFUL PERFORMANCE. SHARP RELIABILITY.

POLY-CRYSTALLINE SILICON PHOTOVOLTAIC MODULE WITH 80W MAXIMUM POWER

Sharp's NE-80EJA photovoltaic modules offer industry-leading performance, durability, and reliability for a variety of electrical power requirements. Using breakthrough technology perfected by Sharp's 45 years of research and development, these modules incorporate an advanced surface texturing process to increase light absorption and improve efficiency. Common applications include cabins, solar power stations, pumps, beacons,



Tipic

ELECTRICAL CHARACTERISTICS

Cell	Poly-crystalline silicon
No. of Cells and Connections	36 in series
Open Circuit Voltage (Voc)	21.6V
Maximum Power Voltage (Vpm)	17.3V
Short Circuit Current (Isc)	5.16A
Maximum Power Current (Ipm)	4.63A
Maximum Power (Pmax)*	80W (+10% / -5%)
Module Efficiency (η_m)	12.40%
Maximum System Voltage	600VDC
Series Fuse Rating	10A
Type of Output Terminal	Junction Box

IV CURVES

Cell Temperature: 25°C

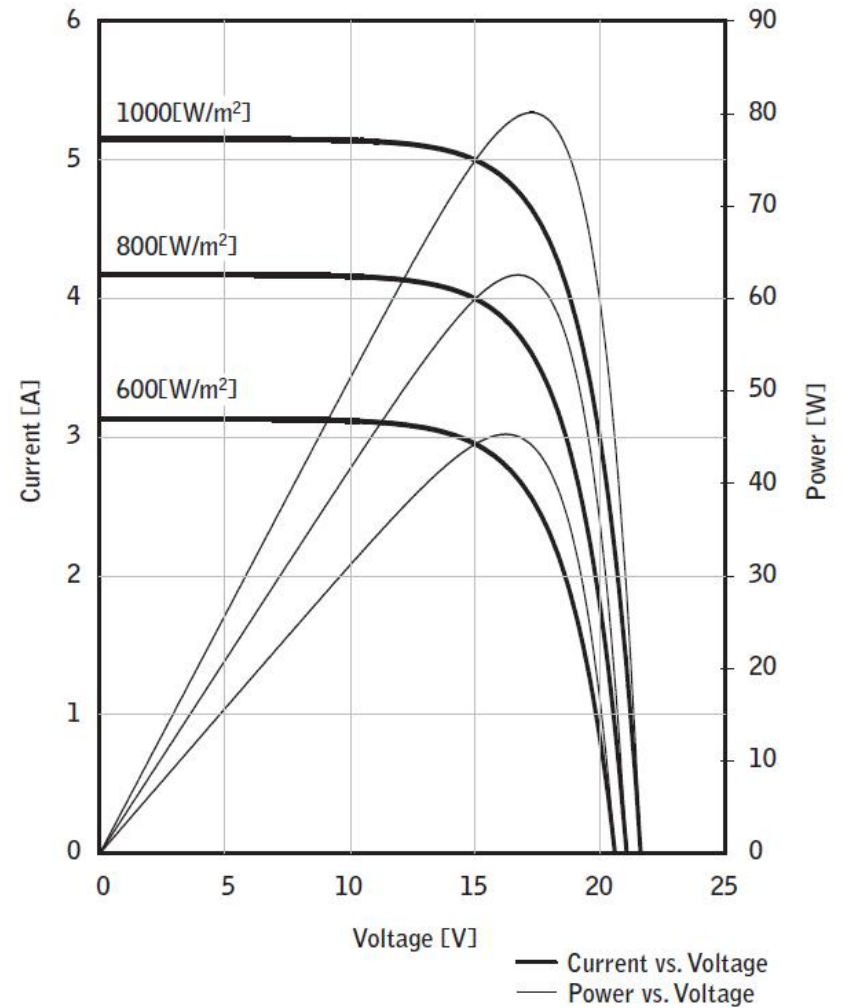

Current, Power vs. Voltage Characteristics

Energia solara disponibila

Sun

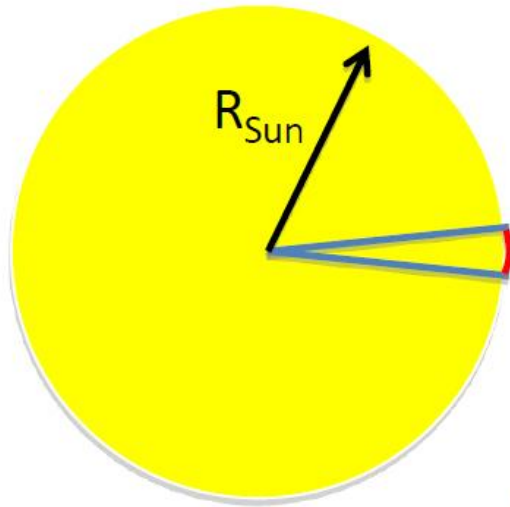

Total Radiative Power of Sun (from Stefan-Boltzman law, $T = 5762 \pm 50K$)

$$P_o = \sigma \cdot T^4$$

Power radiated per unit area
 6.250×10^7
 W/m^2

Assumes Sun is a "black body."

Energia solara disponibila

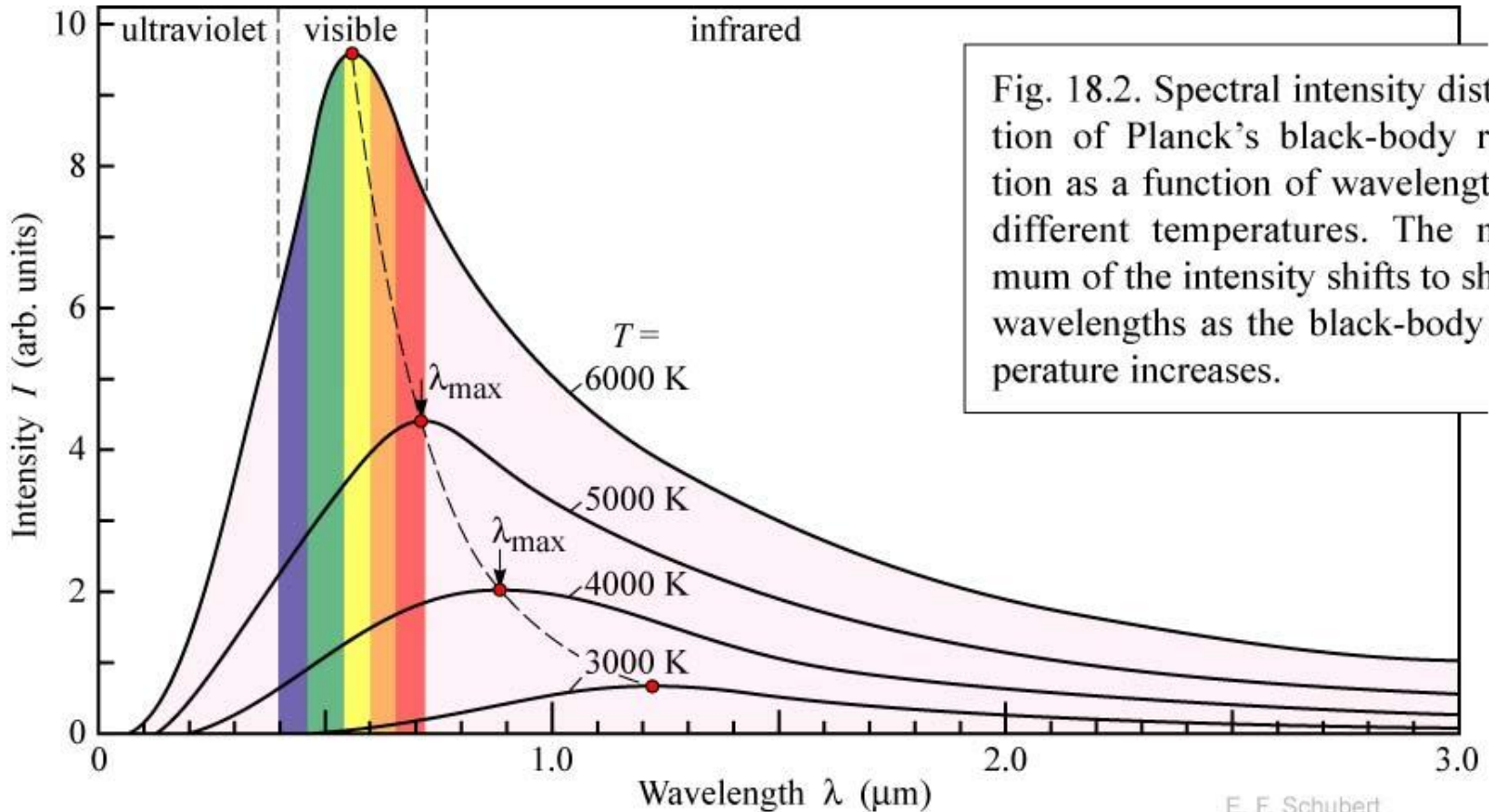
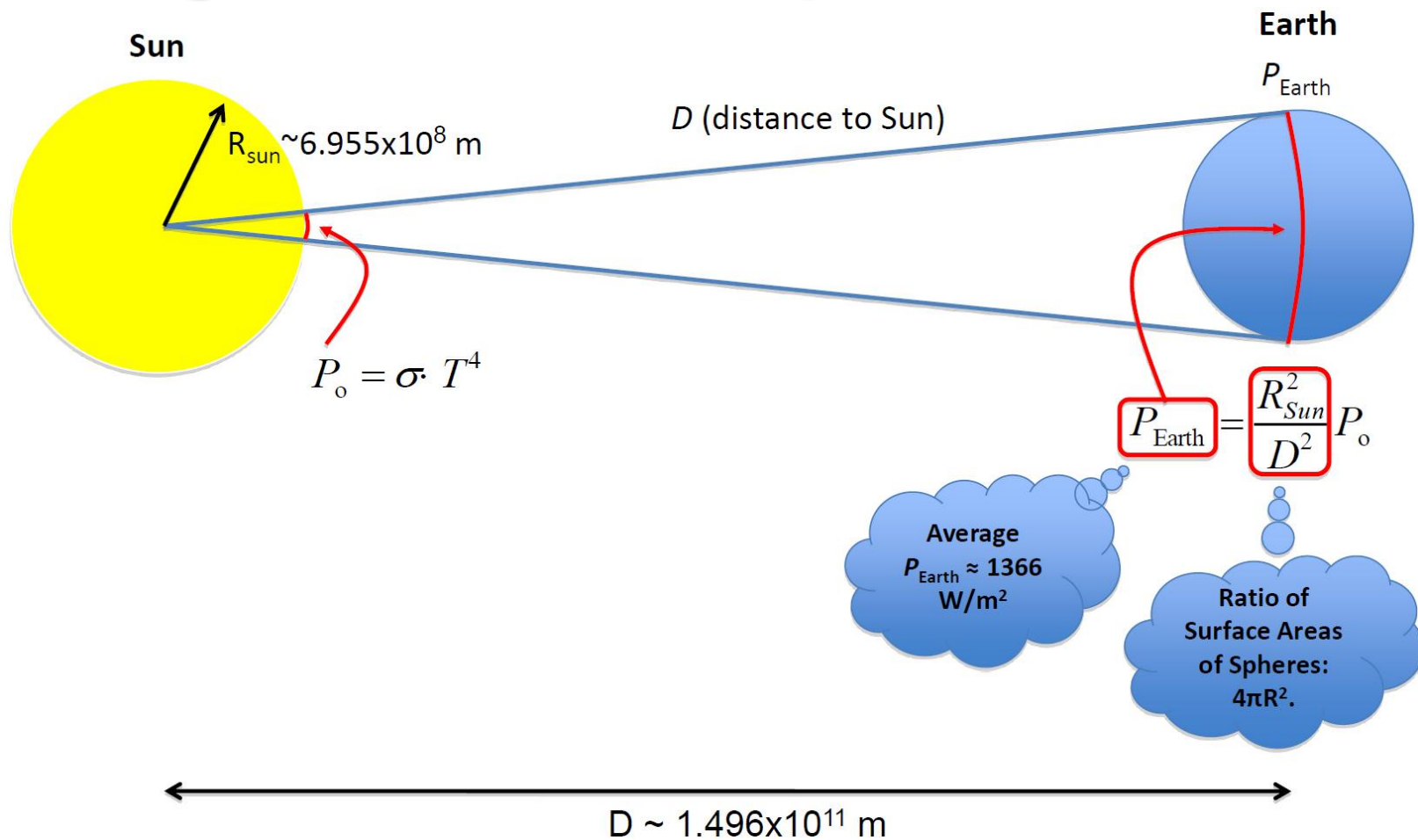

Fig. 18.2. Spectral intensity distribution of Planck's black-body radiation as a function of wavelength for different temperatures. The maximum of the intensity shifts to shorter wavelengths as the black-body temperature increases.

Energia solara disponibila



Energia receptionata pe toata suprafata Pamantului intr-**o ora** mai mare decat toata energia consumata de intreaga populatie intr-**un an**

Energia solara disponibila

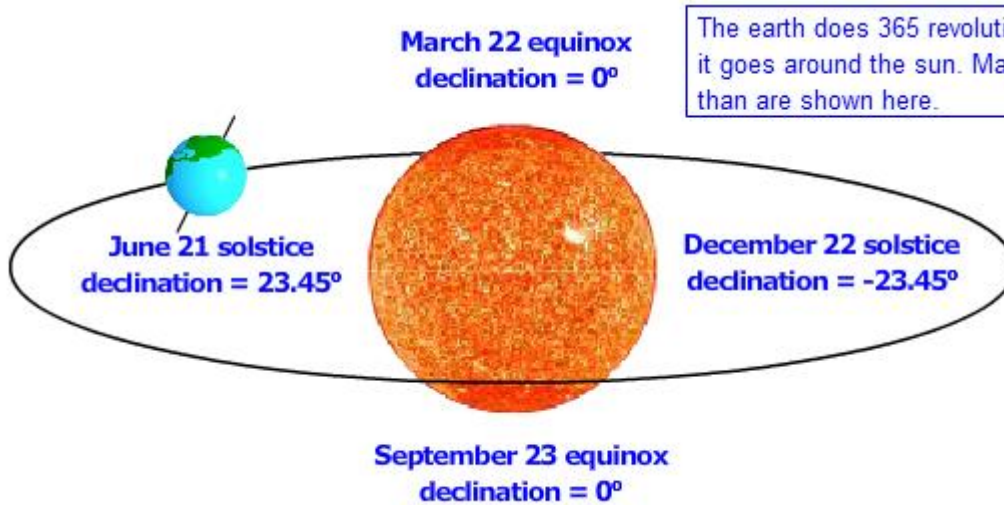

The earth does 365 revolutions as it goes around the sun. Many more than are shown here.

- AM 0 = radiatia in afara atmosferei terestre
- AM 1 = radiatia la suprafata terestra, incidenta normala
- AM 1.5 = radiatia la suprafata terestra, incidenta corespunzatoare latitudinii de 48° (**standard**)

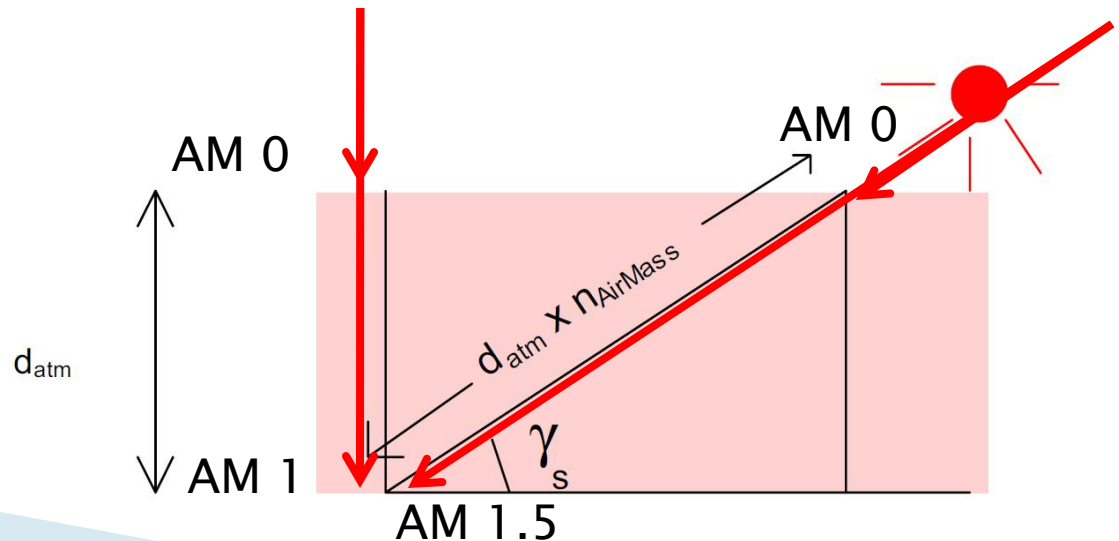

Energia solara disponibila

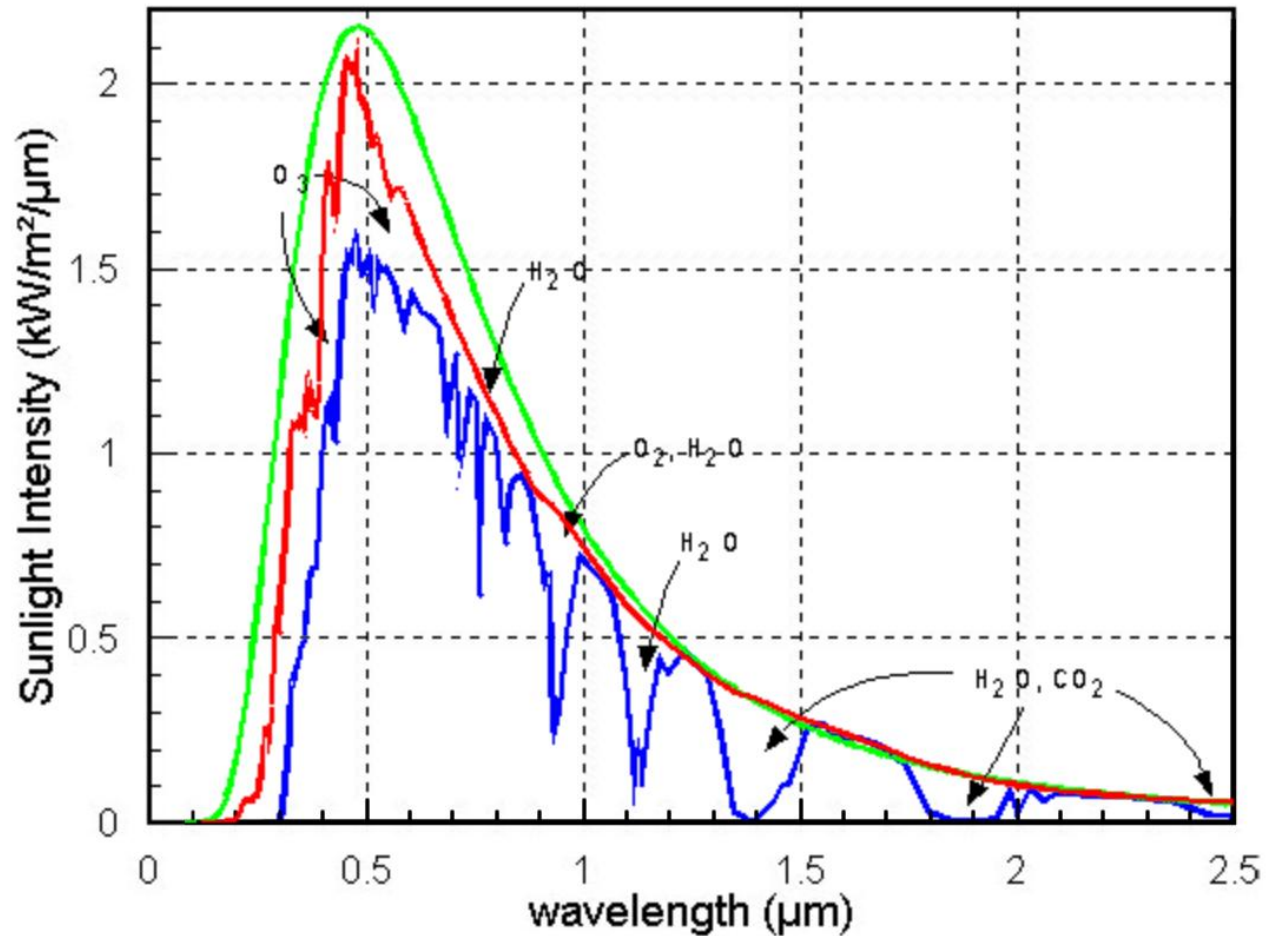

Energia solara disponibila

ASTM G173-03 Reference Spectra

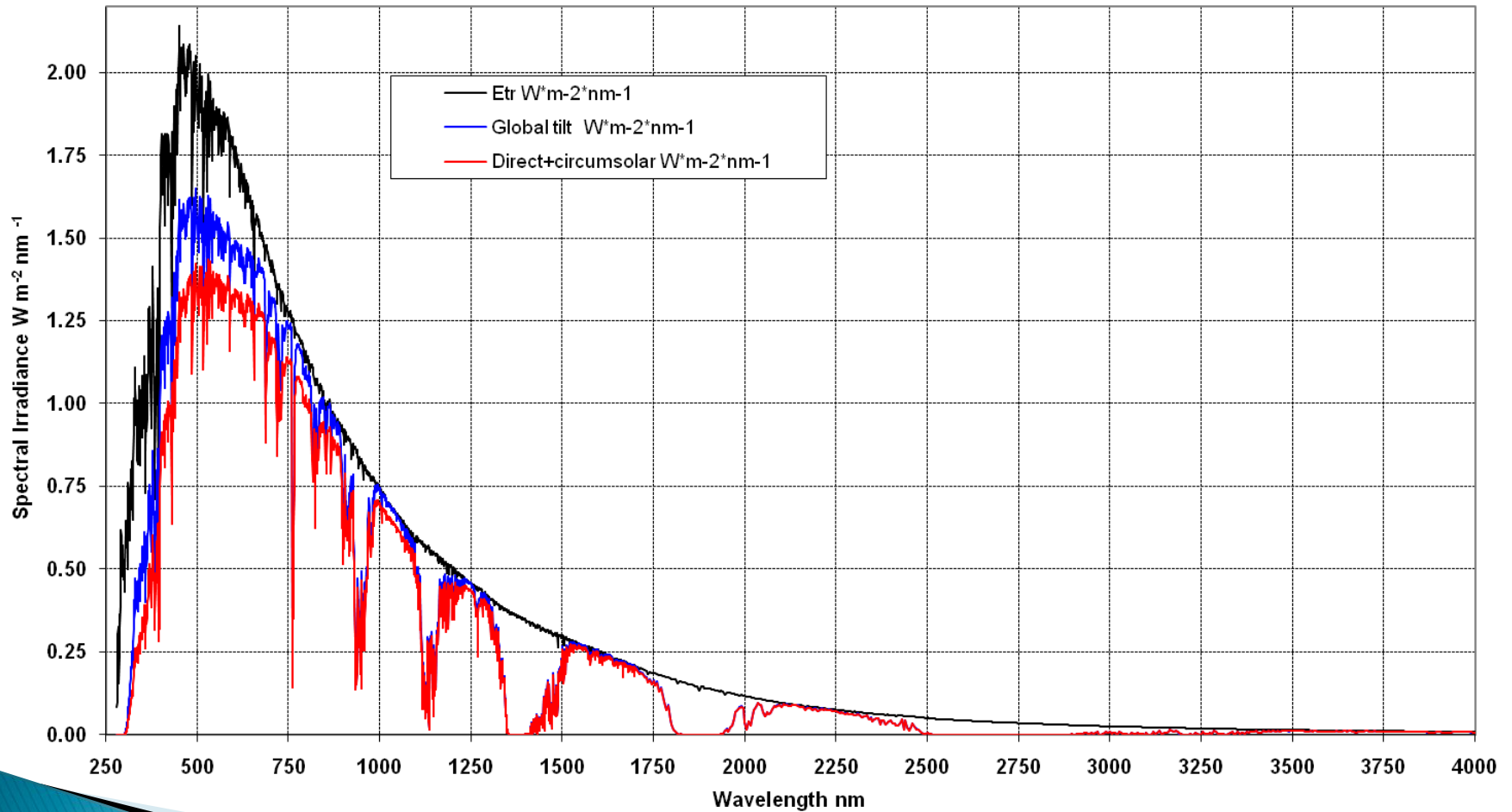

Energia solara disponibile

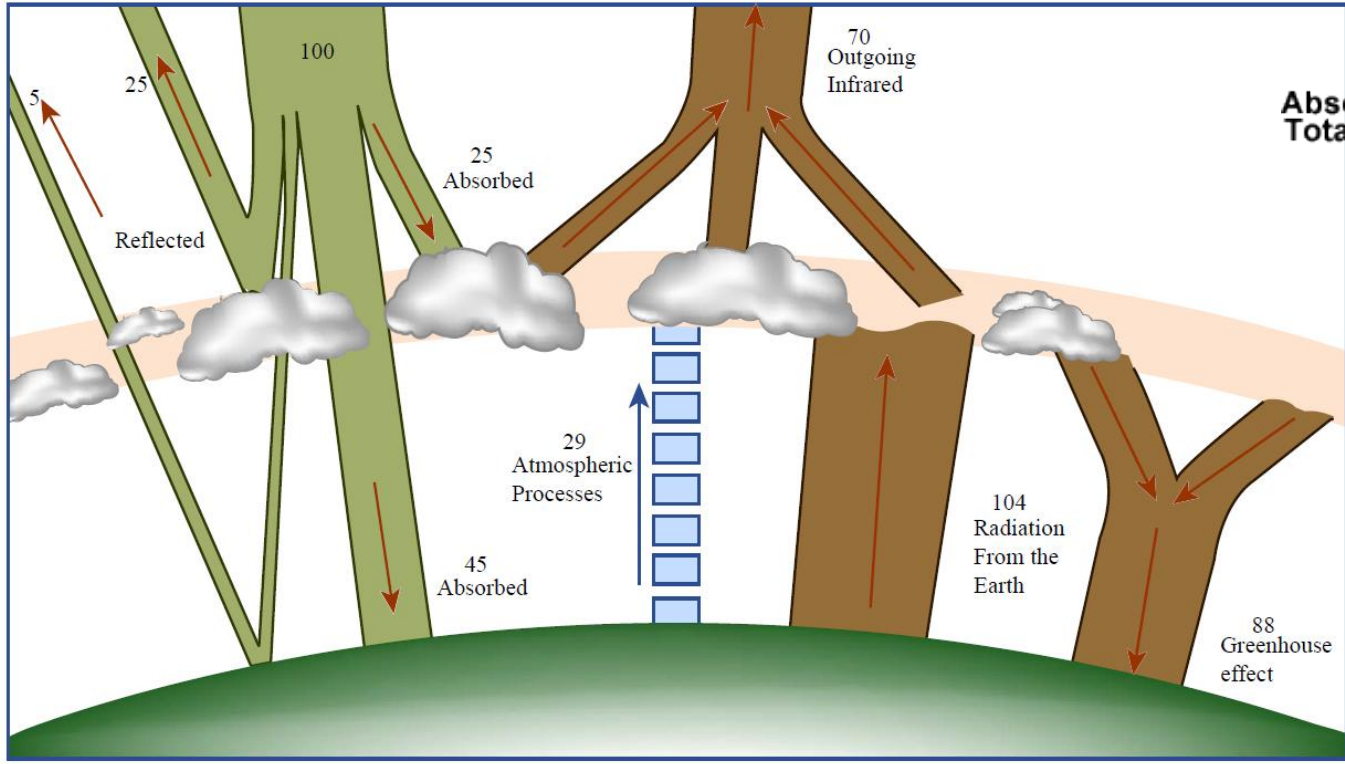

Heat trapping in the atmosphere dominates the earth's energy balance. Some 30% of incoming solar energy is reflected (left), either from clouds and particles in the atmosphere or from the earth's surface; the remaining 70% is absorbed. The absorbed energy is reemitted at infrared wavelengths by the atmosphere (which is also heated by updrafts and cloud formation) and by the surface. Because most of the surface radiation is trapped by clouds and greenhouse gases and returned to the earth, the surface is currently about 33 degrees Celsius warmer than it would be without the trapping.

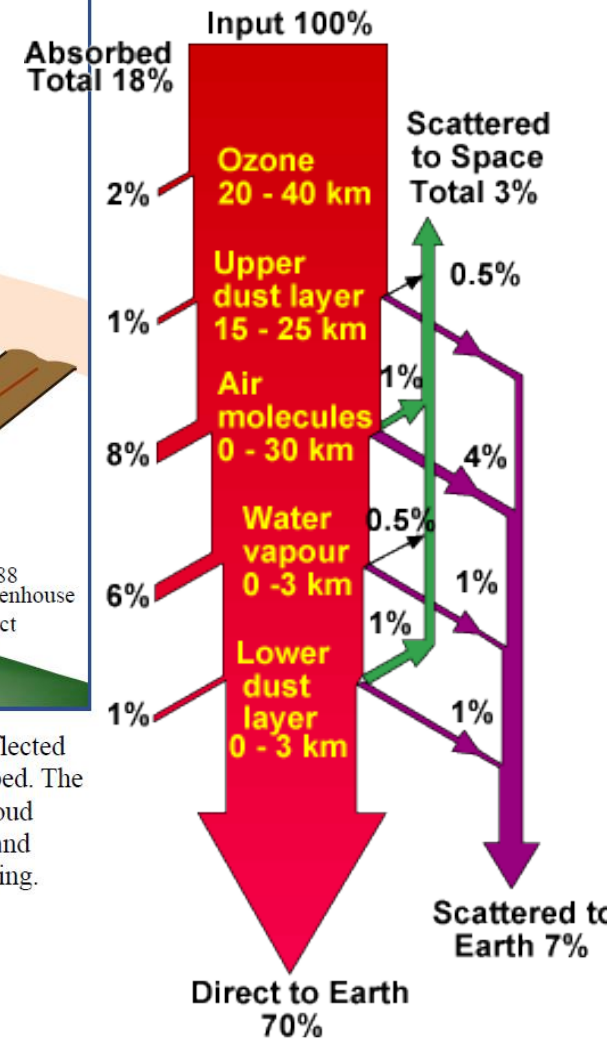

Energia solara disponibila

SOLAR SPECTRUM

AM1.5 Global: Used for testing of Flat Panels (Integrated power intensity: 1000 W/m²)

AM1.5 Direct: Used for testing of concentrators (900 W/m²)

AM0: Outer space (1366 W/m²)

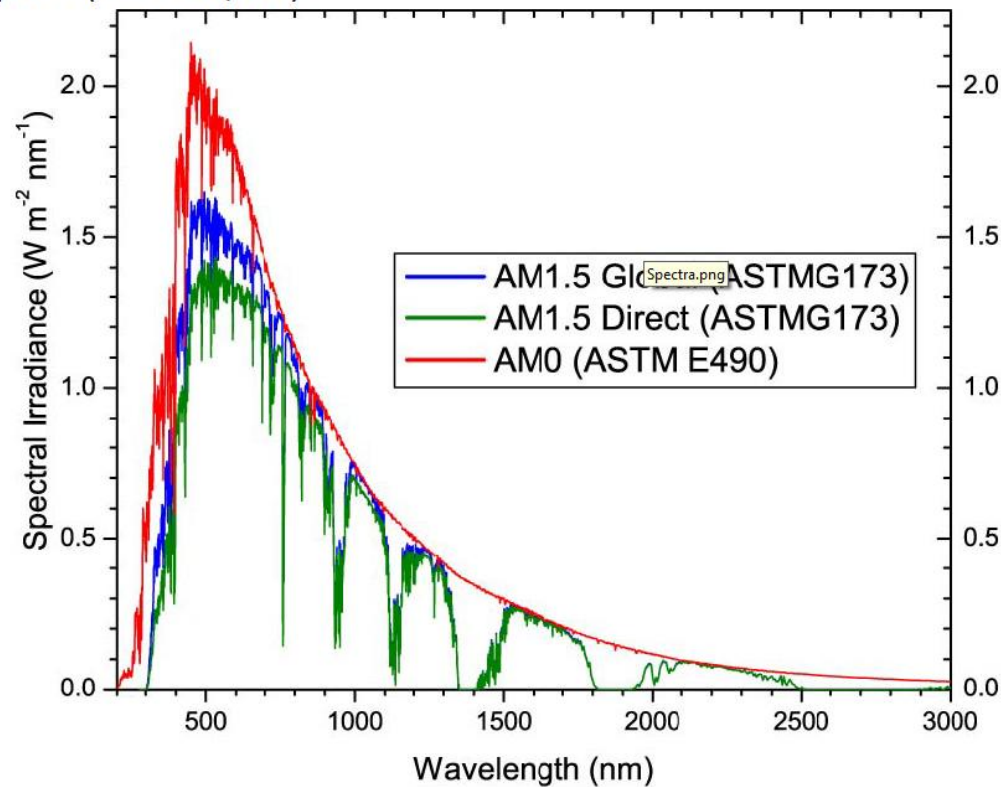

Motivatie eficienta limitata

- ▶ Toate materialele utilizate au o banda care acopera **doar** partial spectrul solar (ex. GaAs)

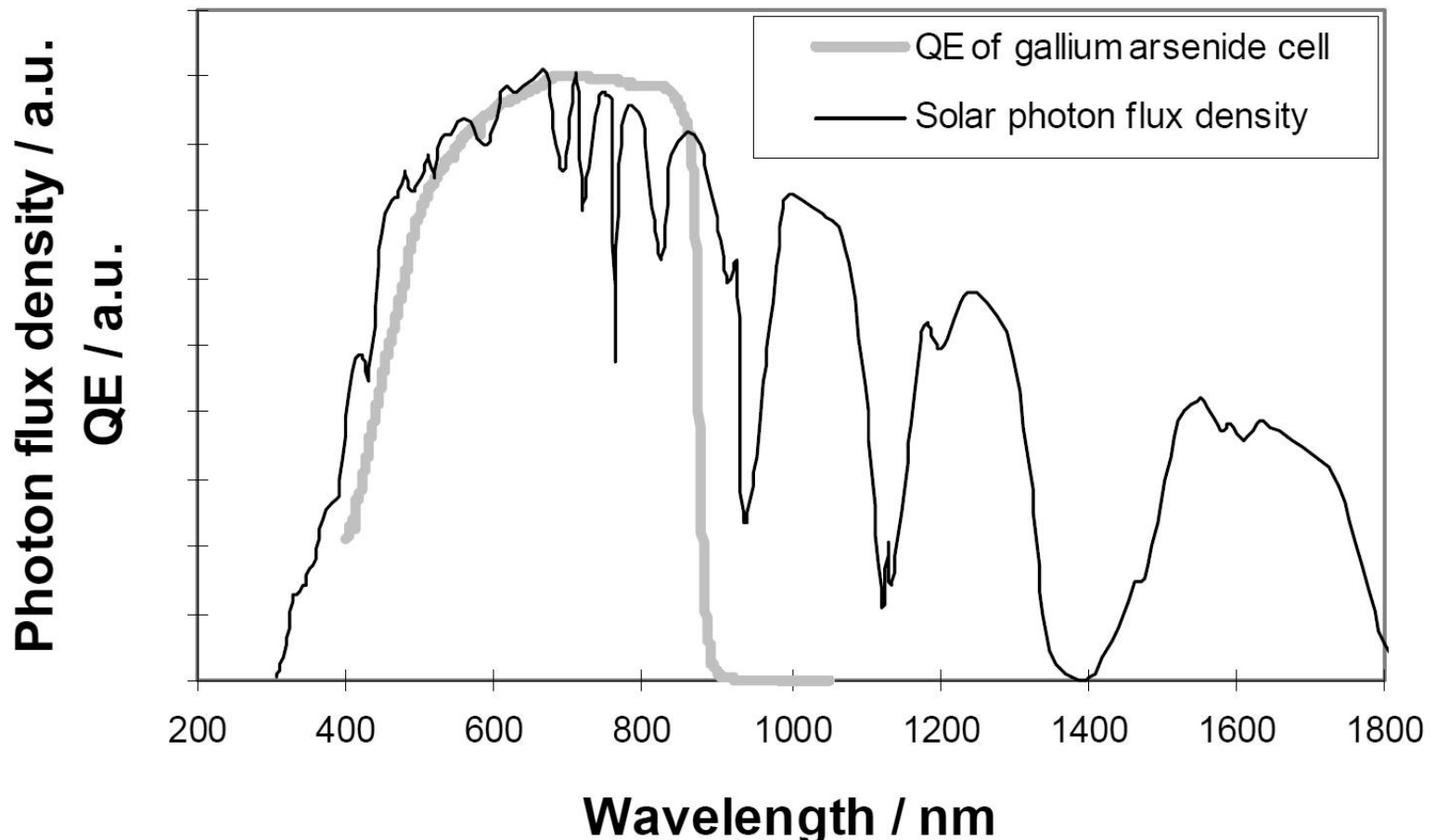

Energia solara disponibile

Photovoltaic Solar Electricity Potential in European Countries

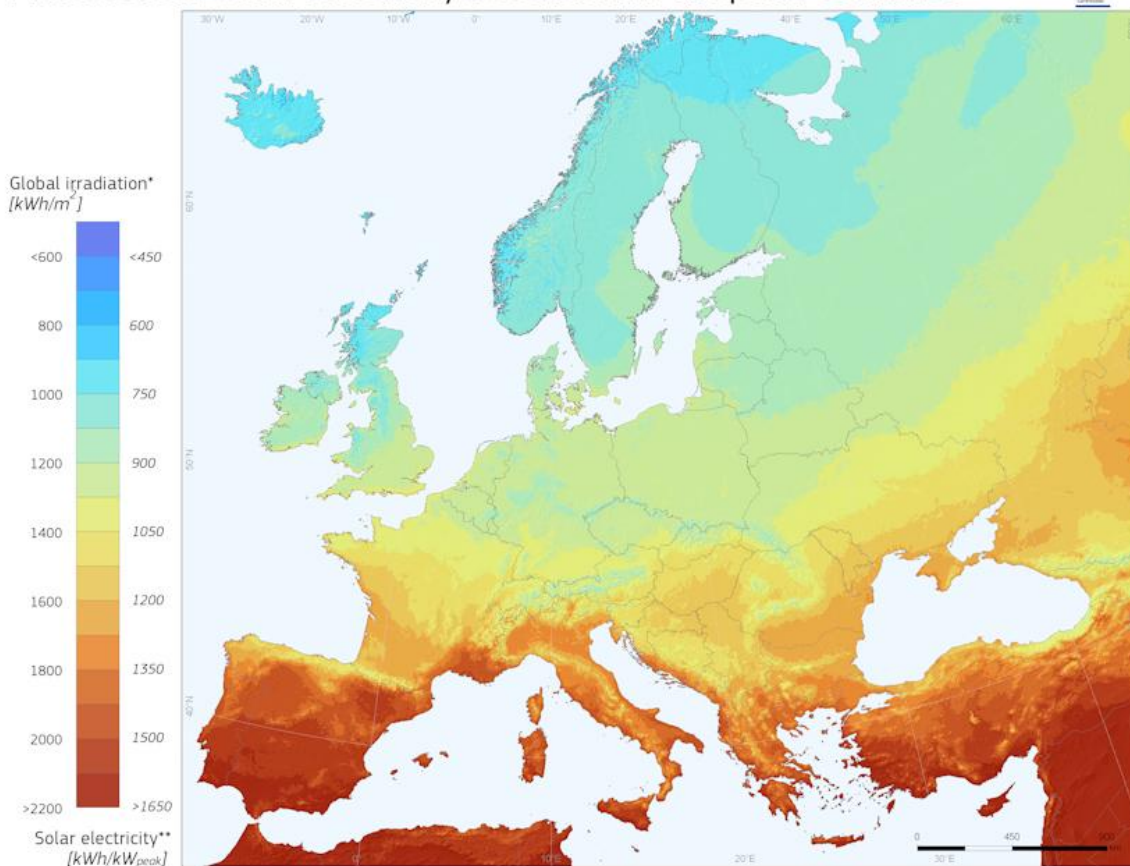

* Yearly sum of global irradiation incident on optimally-inclined south-oriented photovoltaic modules

** Yearly sum of solar electricity generated by optimally-inclined 1kW_p system with a performance ratio of 0.75

© European Union, 2012
PVGIS <http://re.jrc.ec.europa.eu/pvgis/>

Authors: Thomas Huld, Irene Pinedo-Pascua
EC - Joint Research Centre
In collaboration with: CM SAF, www.cmsaf.eu

Legal notice: Neither the European Commission nor any person acting on behalf of the Commission is responsible for the use which might be made of this publication.

<http://re.jrc.ec.europa.eu/pvgis/>

Energia solara disponibila



Global irradiation and solar electricity potential
Optimally-inclined photovoltaic modules

ROMANIA / ROMÂNIA



Yearly sum of global irradiation
[kWh/m²]

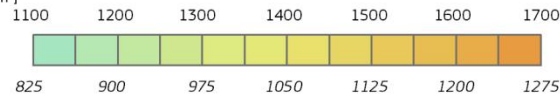

Projection: Lambert Azimuthal Equal Area, WGS84, lat 52° 10' 10"
Source of ancillary data: CORINE Land Cover
DTM SRTM-30
GISCO database
Geonames
Natural Earth

Energia solara disponibile

JRC **CM SAF** **Photovoltaic Geographical Information System - Interactive Maps**

EUROPA > EC > JRC > IE > RE > SOLAREC > PVGIS > Interactive maps > europe **Contact** **Important legal notice**

e.g., "Ispra, Italy" or "45.256N, 16.9589E"
Iasi
cursor position: 46.725, 31.882
selected position: 47.158, 27.601
Latitude: Longitude:

Map Satellite

Ukraine
Vinnytsia Вінниця
Chernivtsi Чернівці
Kirovohra Кіровогра,
Ioldova
Iasi
Chişinău
Odessa Одеса
Bucharest
Constanța
Varna

Romania

Google Map data ©2016 GeoBasis-DE/BKG (©2009), Google, Mapa GISrael, ORION-ME Terms of Use

Solar radiation Temperature Other maps

PV Estimation **Monthly radiation** Daily radiation Stand-alone PV

Monthly global irradiation data
Radiation database: Climate-SAF PVGIS ▾

- Horizontal irradiation
- Irradiation at opt. angle
- Direct normal irradiation
- Irradiation at chosen angle: 90 deg.
- Linke turbidity
- Dif. / global radiation
- Optimal inclination angle

Monthly ambient temperature data

- Average daytime temperature
- Daily average of temperature
- Number of heating degree days

Output options

- Show graphs Show horizon
- Web page Text file PDF

[\[help\]](#)

Photovoltaic Geographical Information System (PVGIS)

<http://re.jrc.ec.europa.eu/pvgis/>

Energia solara disponibila – lasi

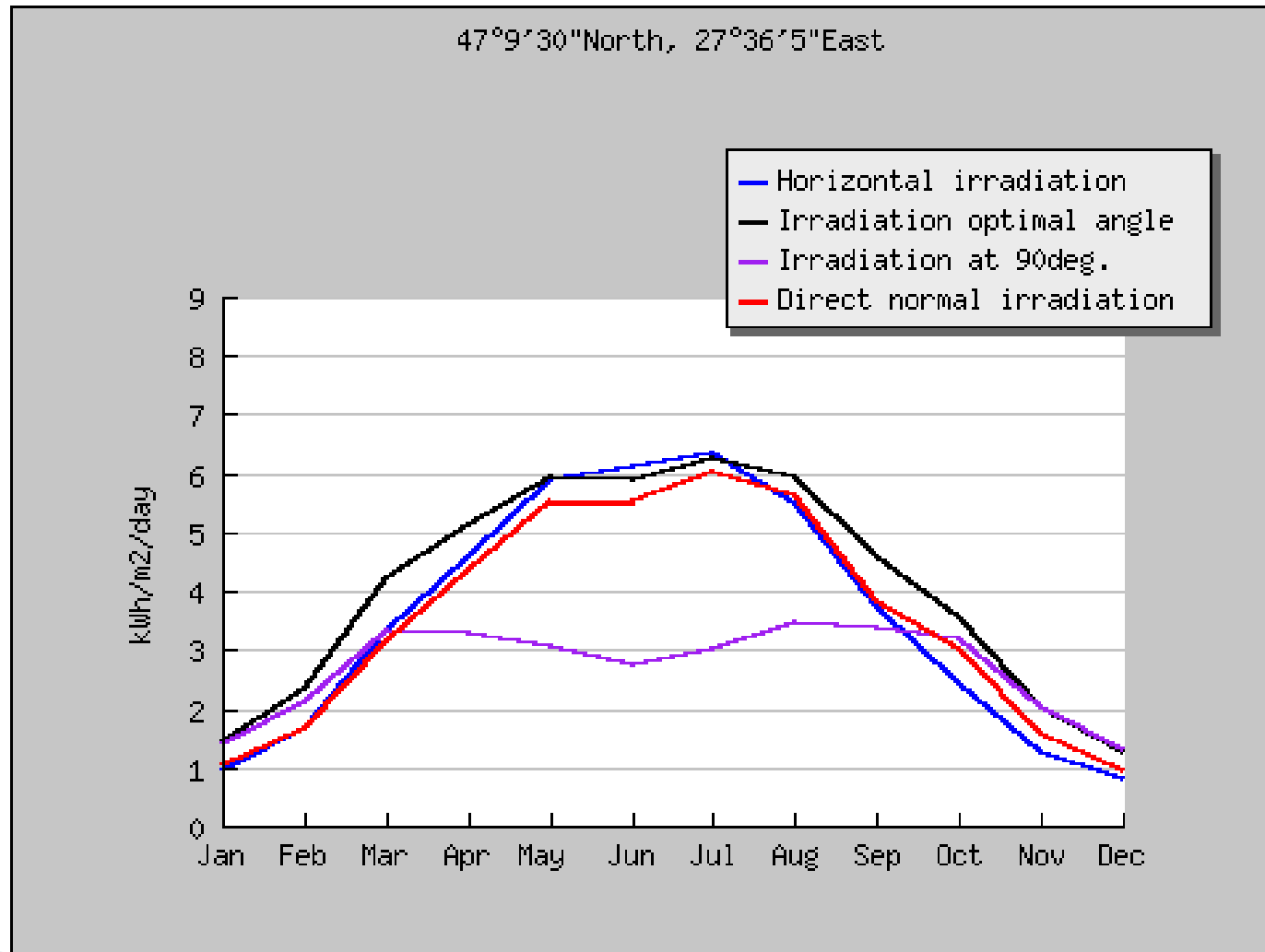

Unghi optim de inclinare

- ▶ Puterea optica depinde de fluxul energetic al luminii incidente si suprafata celulei
 - la **incidenta normala**

$$P_o = S \cdot \int_0^{\infty} \Phi_e(\lambda) d\lambda$$

- la **incidenta oarecare**

$$\Phi_e(\lambda) = \int_{\Sigma} \vec{S} \cdot \vec{n} dA = |S| \cdot A \cdot \cos\alpha$$

$$\vec{S} = \vec{E} \times \vec{H}$$

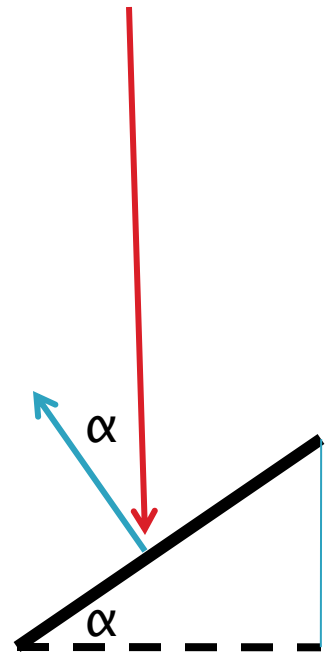

Unghi optim de inclinare

- ▶ Pozitia soarelui este diferita
 - in functie de ora
 - in functie de anotimp



Sisteme de urmarire

- ▶ Sisteme motorizate de urmarire a soarelui
 - o axa
 - doua axe
- ▶ Reglaj
 - fix (optim an)
 - doua pozitii (anotimp)

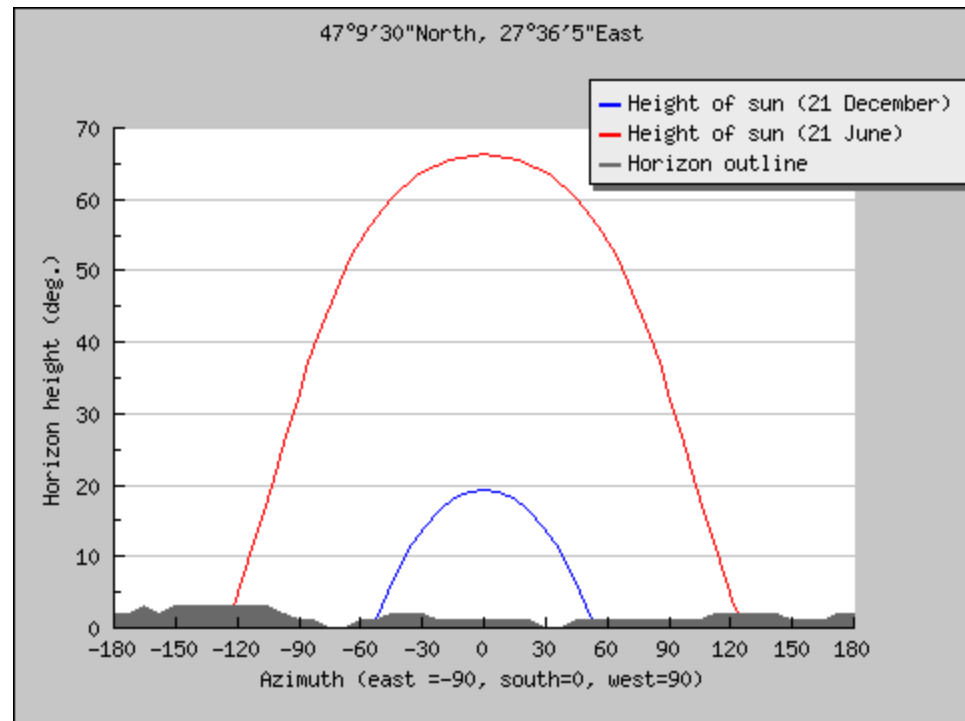

Sisteme de urmarire

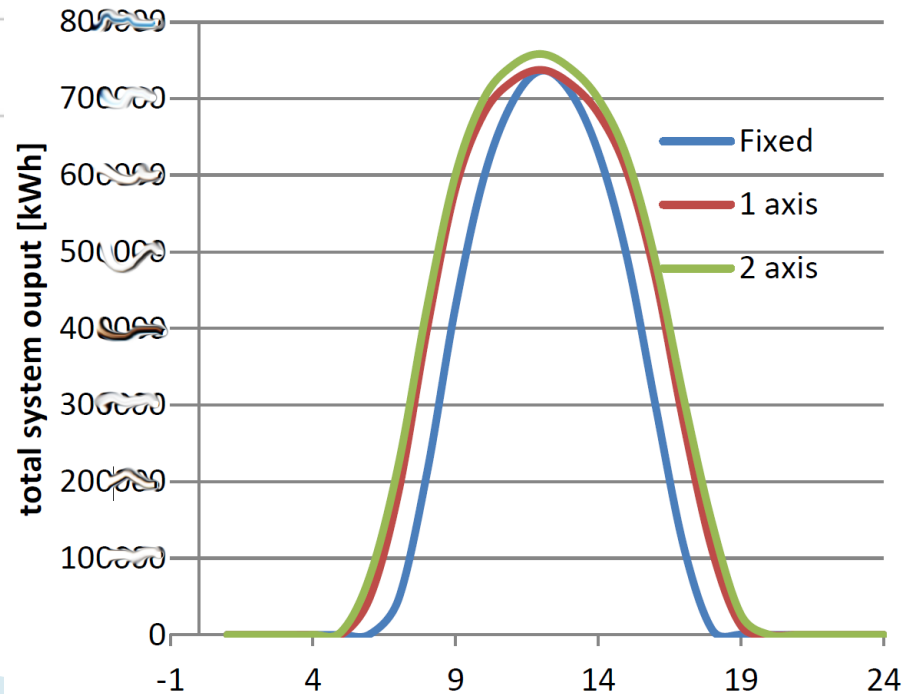
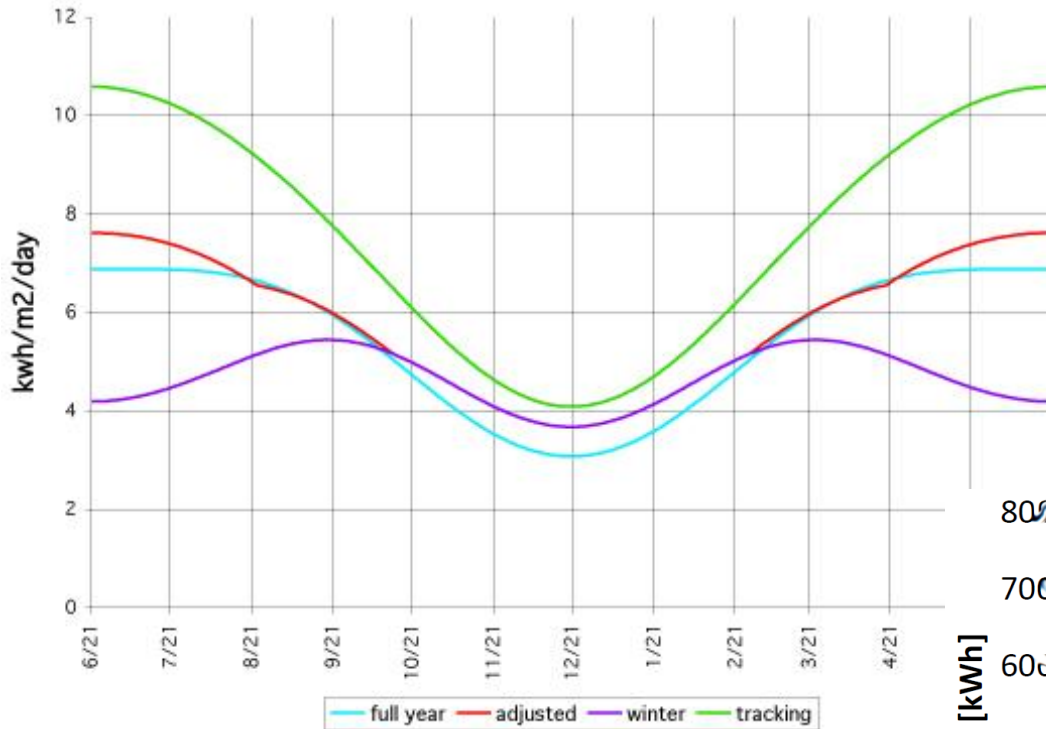

Unghi optim de inclinare

- ▶ Panourile se orienteaza spre sud (**geografic**)
- ▶ Inclinarea pe verticala se poate calcula din considerente
 - geometrice
 - astronomice

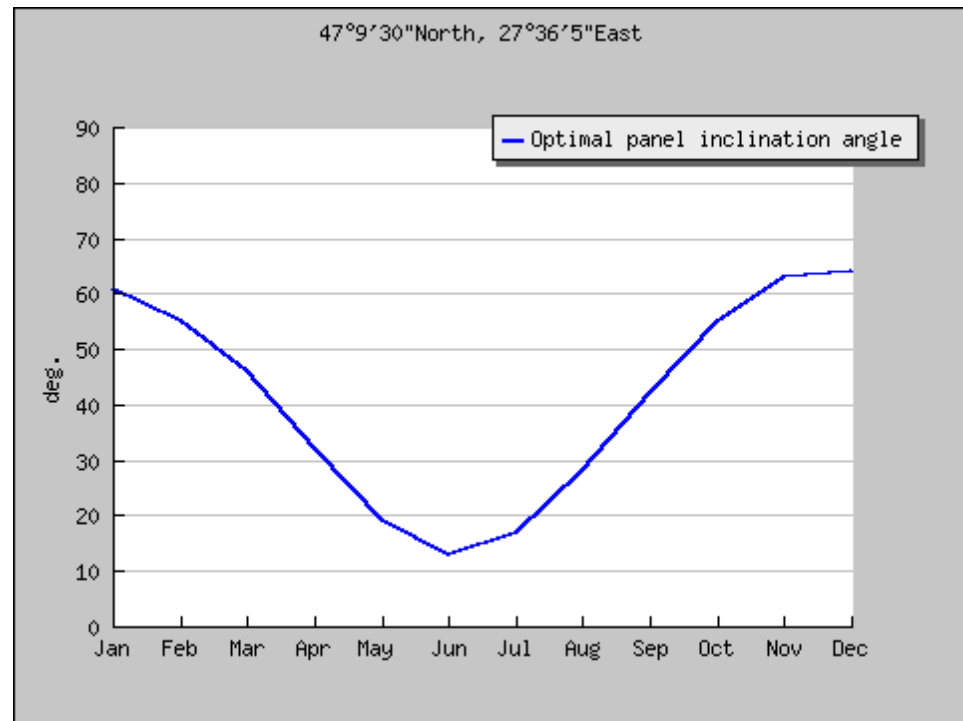

lasi

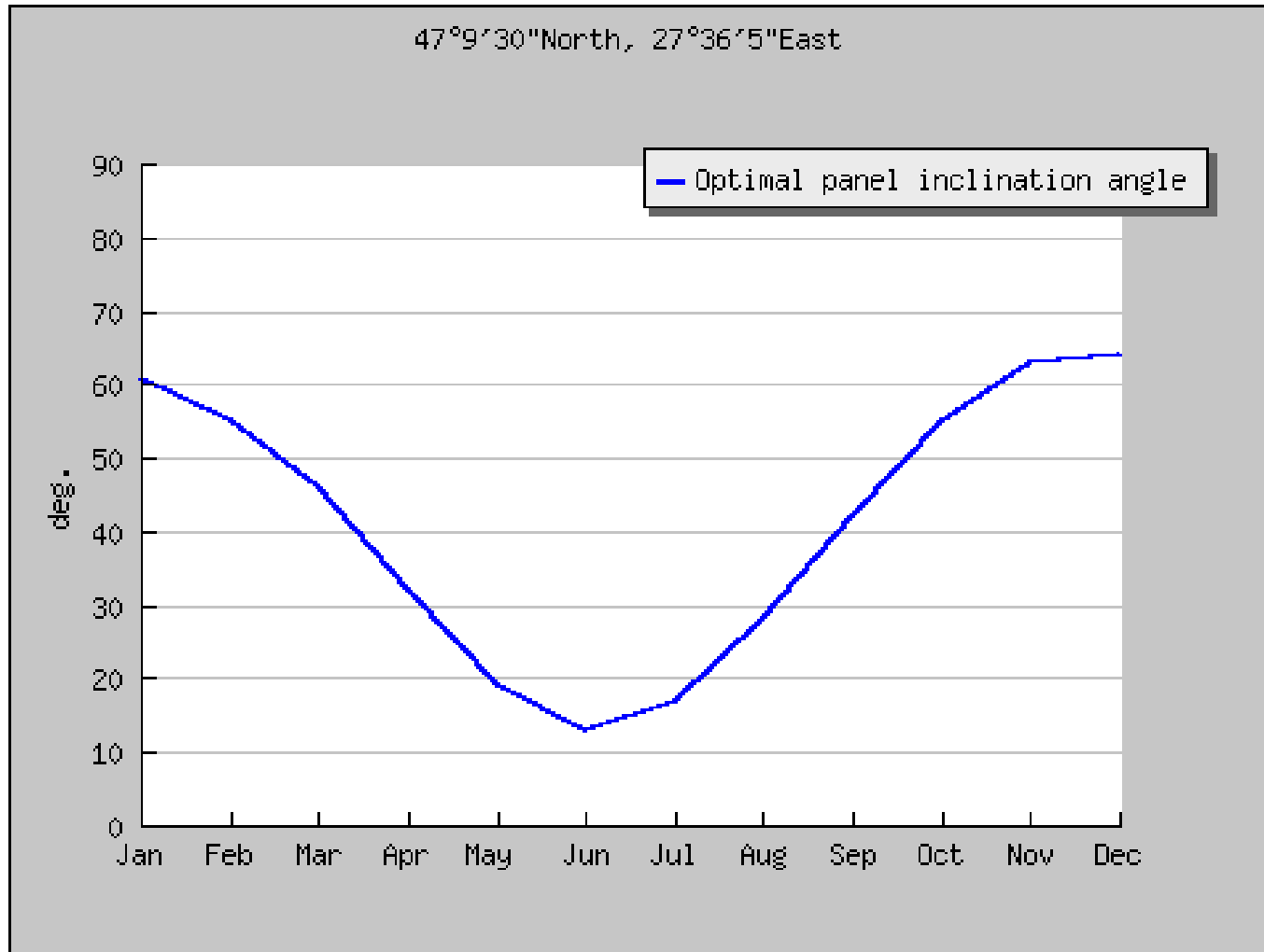

Tip de sistem de urmarire

- ▶ depinde de tipul de sistem solar
 - cu concentrare
 - fara concentrare
- ▶ depinde de conditii meteorologice

Global horizontal irradiation (1985-2004)
(annual average of daily sums, Gh)

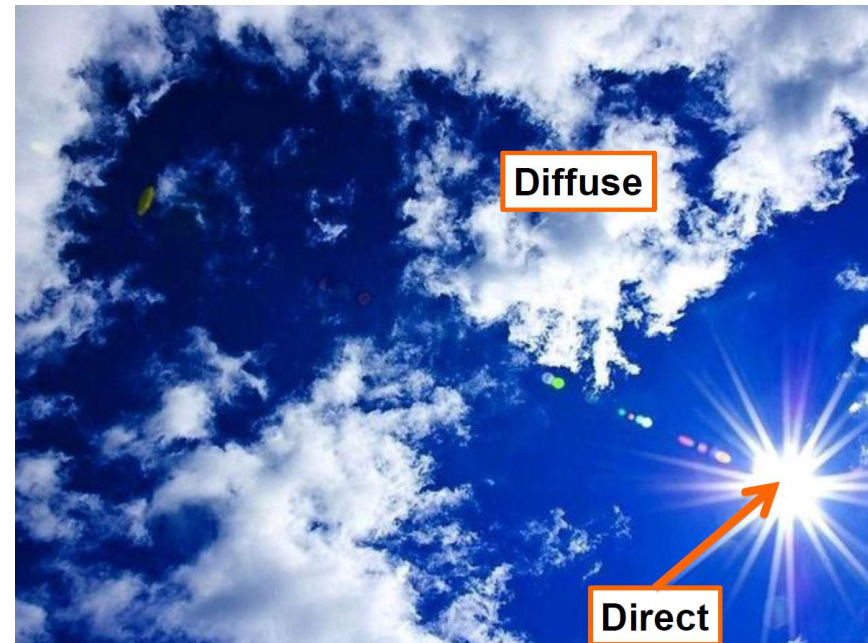
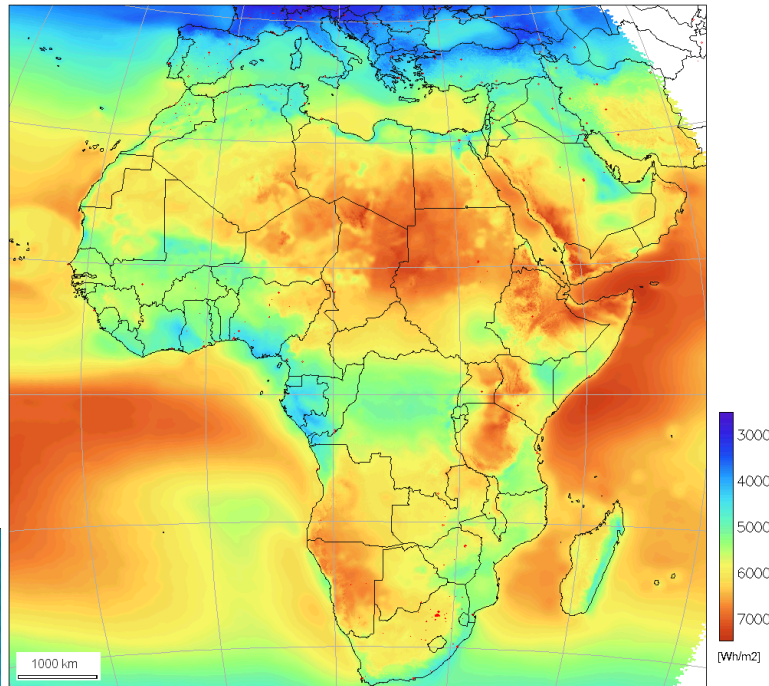

Energia solara disponibila

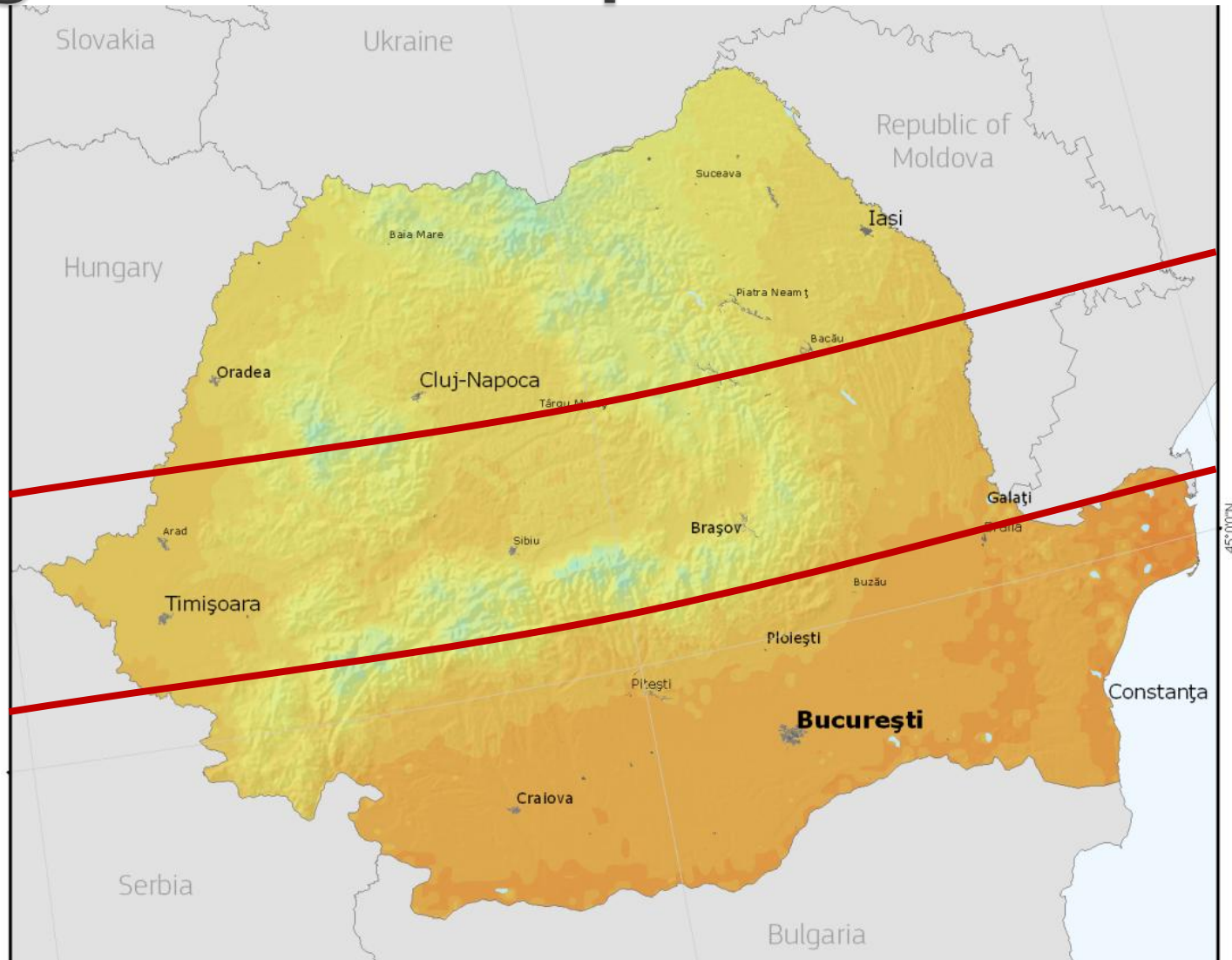

lasi

Month	H_h	H_{opt}	H(90)	DNI	I_{opt}	T_{24h}
Jan	956	1440	1410	1020	61	-2.5
Feb	1680	2350	2130	1670	55	-1.4
Mar	3310	4210	3330	3150	46	4.0
Apr	4580	5150	3280	4380	32	10.6
May	5900	5960	3070	5530	19	16.7
Jun	6140	5900	2760	5530	13	20.0
Jul	6320	6240	3010	6010	17	22.3
Aug	5470	5960	3460	5630	28	21.4
Sep	3720	4600	3390	3820	42	16.1
Oct	2450	3570	3210	3000	55	10.2
Nov	1260	2000	2010	1600	63	5.5
Dec	802	1280	1310	959	64	-0.8
Year	3560	4070	2700	3540	35	10.2

Iasi

<http://re.jrc.ec.europa.eu/pvgis/>

Mont h	H_h	H_{opt}	H(90)	DNI	I_{opt}	T_{24h}
Jan	956	1440	1410	1020	61	-2.5
Feb	1680	2350	2130	1670	55	-1.4
Mar	3310	4210	3330	3150	46	4.0
Apr	4580	5150	3280	4380	32	10.6
May	5900	5960	3070	5530	19	16.7
Jun	6140	5900	2760	5530	13	20.0
Jul	6320	6240	3010	6010	17	22.3
Aug	5470	5960	3460	5630	28	21.4
Sep	3720	4600	3390	3820	42	16.1
Oct	2450	3570	3210	3000	55	10.2
Nov	1260	2000	2010	1600	63	5.5
Dec	802	1280	1310	959	64	-0.8
Year	3560	4070	2700	3540	35	10.2

H_h : Irradiation on horizontal plane (Wh/m²/day)

H_{opt} : Irradiation on optimally inclined plane (Wh/m²/day)

$H(90)$: Irradiation on plane at angle: 90deg. (Wh/m²/day)

DNI : Direct normal irradiation (Wh/m²/day)

I_{opt} : Optimal inclination (deg.)

T_{24h} : 24 hour average of temperature (°C)

Romania

Global horizontal irradiation

Romania

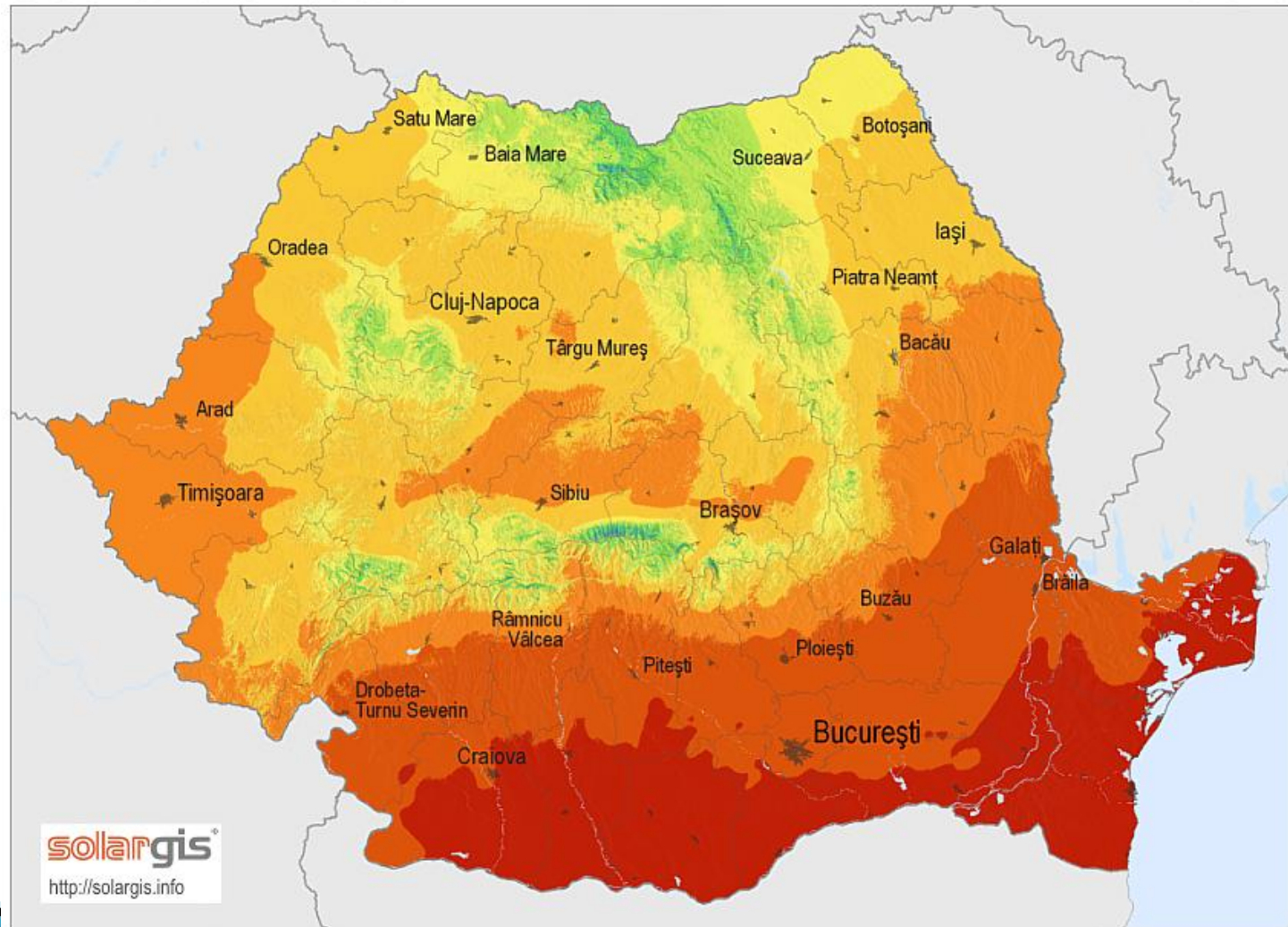

solargis
<http://solargis.info>

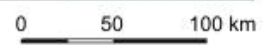
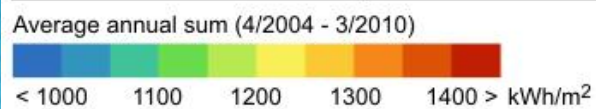

2019

- ▶ Schimbare de:
 - adresa
 - aplicatie
- ▶ Alte modalitati de prezentare a rezultatelor
 - acces la date individuale 2007 – 2016
 - unitati de masura diferite (kWh/m²/**luna**)
 - lipsesc unele date (unghi optim lunar, H90)

http://re.jrc.ec.europa.eu/pvg_tools/en/tools.html

2019

re.jrc.ec.europa.eu/pvg_tools/en/tools.html#MR

Home Tools Download Documentation About us News

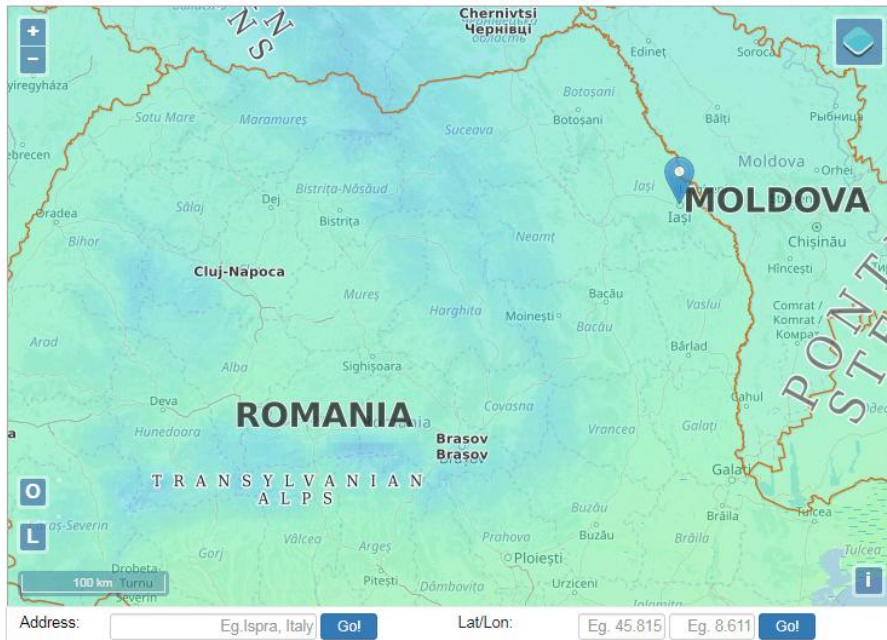

Cursor:

Selected: 47.160, 27.585
Elevation (m): 57

Use terrain shadows:

Calculated horizon
 Upload horizon file

Download CSV

Choose File | No file chosen

GRID CONNECTED

TRACKING PV

OFF-GRID

MONTHLY DATA

DAILY DATA

HOURLY DATA

TMY

MONTHLY IRRADIATION DATA

Solar radiation database*

PVGIS-CMSAF

Start year:*

2007

End year:*

2007

Irradiation:

- Global horizontal irradiation
- Direct normal irradiation
- Global irradiation optimum angle
- Global irradiation at angle: (0-90)

Ratio:

Diffuse/global ratio

Temperature:

Average temperature

Visualize results

Download csv

MONTHLY IRRADIATION DATA: RESULTS

Radiation

Diffuse/Global

Temperature

Info

PDF

Summary

Provided inputs:

Location [Lat/Lon]: 47.160, 27.585
Horizon: Calculated
Database used: PVGIS-CMSAF
Start year: 2007
End year: 2007

Monthly solar irradiation estimates

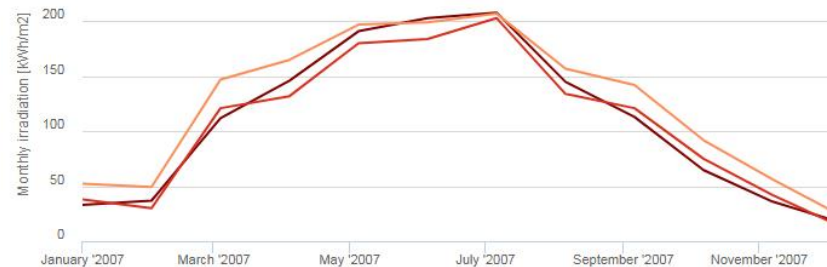

Outline of horizon

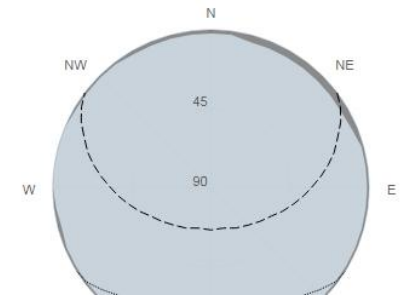

Iasi, date 2016

Month	H_h	H_{opt}	DNI	D/G	T_{24h}
Jan	34.8	55.5	39	0.67	-2.3
Feb	50.5	72.2	50	0.63	4.1
Mar	100	128	94	0.51	5.2
Apr	147	167	141	0.43	12.4
May	168	169	141	0.46	14.2
Jun	184	180	162	0.4	20.2
Jul	215	215	216	0.33	21.7
Aug	174	191	185	0.35	20.4
Sep	130	164	149	0.38	17
Oct	55.2	73.7	54	0.59	6.6
Nov	36.3	58.5	44	0.62	2.8
Dec	29.6	49.2	35	0.68	-1

Iasi, date 2015

Month	H_h	H_{opt}	DNI	D/G	T_{24h}
Jan	29.5	45.6	31	0.71	-0.9
Feb	50.6	73.5	53	0.61	-0.2
Mar	95.4	123	94	0.51	4.1
Apr	142	160	134	0.44	9.1
May	190	193	177	0.39	16.6
Jun	209	205	200	0.35	19.7
Jul	199	200	187	0.36	22.8
Aug	173	189	180	0.35	22.6
Sep	113	140	118	0.42	17.6
Oct	73.7	107	85	0.51	8
Nov	38.3	61.6	48	0.59	6.1
Dec	34.7	64	52	0.6	1.1

Iasi, date 2016

Month	H _h	H _{opt}	DNI	D/G	T _{24h}
Jan	34.8	55.5	39	0.67	-2.3
Feb	50.5	72.2	50	0.63	4.1
Mar	100	128	94	0.51	5.2
Apr	147	167	141	0.43	12.4
May	168	169	141	0.46	14.2
Jun	184	180	162	0.4	20.2
Jul	215	215	216	0.33	21.7
Aug	174	191	185	0.35	20.4
Sep	130	164	149	0.38	17
Oct	55.2	73.7	54	0.59	6.6
Nov	36.3	58.5	44	0.62	2.8
Dec	29.6	49.2	35	0.68	-1

Hh: Irradiation on horizontal plane (kWh/m²/month)

Hopt: Irradiation on optimally inclined plane (kWh/m²/month)

DNI: Direct normal irradiation (kWh/m²/month)

D/G: Ratio of diffuse to global irradiation (-)

T24h: 24 hour average of temperature (-C)

Contact

- ▶ Laboratorul de microunde si optoelectronica
 - ▶ <http://rf-opto.etti.tuiasi.ro>
 - ▶ rdamian@etti.tuiasi.ro

 - ▶ <http://ocw.mit.edu/>
 - ▶ MIT Course Number 2.627
 - ▶ Fundamentals of Photovoltaics

 - ▶ http://re.jrc.ec.europa.eu/pvg_tools/en/tools.html
 - ▶ <http://www.pveducation.org/>
- 