

Optoelectronică

Curs 7

2017/2018

Disciplina 2017/2018

- ▶ 2C/1L Optoelectronică **OPTO**
- ▶ **Minim 7** prezente curs + laborator
- ▶ Curs – **conf. Radu Damian**
 - an IV μ E
 - Vineri 8-11, P5
 - E – 70% din nota
 - **20% test la curs**, saptamana 4-5?
 - probleme + (? 1 subiect teorie) + (2p prez. curs)
 - toate materialele permise
- ▶ Laborator – **sl. Daniel Matasaru**
 - an IV μ E, an IV Tc
 - Joi 14-16 par/impar
 - L – 15% din nota
 - C – 15% din nota

Orar 2017/2018

▶ Curs

- Vineri 8–11, P5
- **2C ⇒ 3C**
 - $14 * 2/3 \approx 9.33$
 - $9 \div 10$ C

Recapitulare

Reprezentare logaritmică!!!

$$\text{dB} = 10 \cdot \log_{10} (P_2 / P_1)$$

$$\text{dBm} = 10 \cdot \log_{10} (P / 1 \text{ mW})$$

$$0 \text{ dB} = 1$$

$$+ 0.1 \text{ dB} = 1.023 (+2.3\%)$$

$$+ 3 \text{ dB} = 2$$

$$+ 5 \text{ dB} = 3$$

$$+ 10 \text{ dB} = 10$$

$$-3 \text{ dB} = 0.5$$

$$-10 \text{ dB} = 0.1$$

$$-20 \text{ dB} = 0.01$$

$$-30 \text{ dB} = 0.001$$

$$0 \text{ dBm} = 1 \text{ mW}$$

$$3 \text{ dBm} = 2 \text{ mW}$$

$$5 \text{ dBm} = 3 \text{ mW}$$

$$10 \text{ dBm} = 10 \text{ mW}$$

$$20 \text{ dBm} = 100 \text{ mW}$$

$$-3 \text{ dBm} = 0.5 \text{ mW}$$

$$-10 \text{ dBm} = 100 \mu\text{W}$$

$$-30 \text{ dBm} = 1 \mu\text{W}$$

$$-60 \text{ dBm} = 1 \text{ nW}$$

$$[\text{dBm}] + [\text{dB}] = [\text{dBm}]$$

$$[\text{dBm/Hz}] + [\text{dB}] = [\text{dBm/Hz}]$$

$$[\text{x}] + [\text{dB}] = [\text{x}]$$

Dimensionarea unei legături pe fibra optică

Capitolul 6

Legatura pe fibra optica

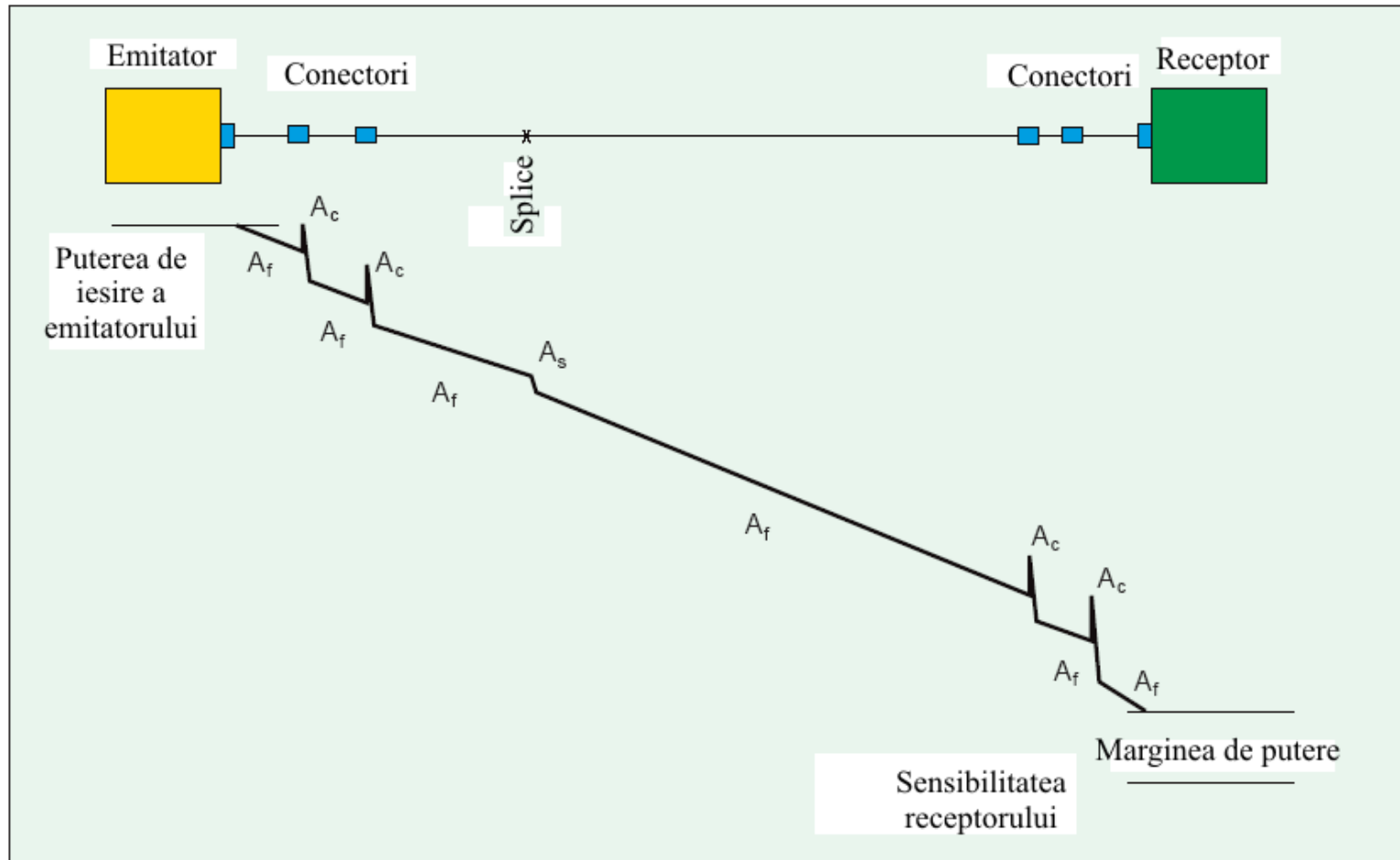

Pierderi

- ▶ Atenuare in fibra
- ▶ Atenuare datorata conectorilor
- ▶ Atenuare datorata splice-urilor
- ▶ Atenuare datorata diferentelor de apertura numerica
 - apare **numai** la trecerea de la un dispozitiv cu NA mai mare la un dispozitiv cu NA mai mic
 - **neglijabil** intre 2 fibre monomod sudate
- ▶ Atenuare datorata diferentelor de diametru
 - apare **numai** la trecerea de la un dispozitiv cu diametru mai mare la un dispozitiv cu diametru mai mic
 - **bidirectional** la fibre monomod sudate

Dispersie

$$\Delta\tau_{\text{mod}} \cong \frac{L \cdot n_2 \cdot \Delta}{2\sqrt{3} \cdot c} \approx \frac{L \cdot NA^2}{4\sqrt{3} \cdot c \cdot n_2}$$

$$\Delta\tau_{\text{mod}} \cong \frac{L \cdot n_2 \cdot \Delta^2}{4\sqrt{3} \cdot c} \cong \frac{L \cdot NA^4}{16\sqrt{3} \cdot c \cdot n_2^3}$$

$$\Delta\tau_{cr} = D(\lambda) \cdot \Delta\lambda \cdot L$$

$$D(\lambda) = \frac{S_0}{4} \cdot \left(\lambda - \frac{\lambda_0^4}{\lambda^3} \right)$$

$$\Delta\tau_{tip} = \sum_i \Delta\tau_i$$

$$\Delta\tau_{tot} = \sqrt{\Delta\tau_{cr}^2 + \Delta\tau_{mod}^2}$$

$$B_{opt} = \frac{0.44}{\Delta\tau_{tot} [ns]} [GHz] \quad B_{opt} = \sqrt{2} B_{el}$$

$$V [Gb/s] \cong 2 \cdot B_{el}$$

$$B_{3dB,electric} (GHz) = \frac{0.35}{T(ns)}$$

$$NRZ_{viteza\ date} (Gbit/s) = \frac{1}{T_{impuls}(ns)} \leq \frac{0.67}{T(ns)}$$

Lungime maxima

- ▶ **limitata de atenuare** L_{\max}^a [km]
- ▶ **limitata de viteza** L_{\max}^v [km]

- ▶ lungimea cea mai mare la care pot face transmisia este obtinuta in cazul cel mai defavorabil (din cele doua limitari)

$$L_{\max} [\text{km}] = \min(L_{\max}^a [\text{km}], L_{\max}^v [\text{km}])$$

- ▶ **de obicei**
 - monomod: limita impusa de atenuare
 - cu exceptia cazurilor in care nu se functioneaza la λ optim dpdv al dispersiei
 - multimod: limita impusa de viteza

Problema simpla?

- ▶ Sursa luminoasa: 7.7 dBm
- ▶ Atenuarea fibrei: 1.16 dB/km
- ▶ Puterea la iesire: 105 μ W

- ▶ Lungimea fibrei: ?

LED

Dioda electroluminescenta
Capitolul 7

Lățimea benzii interzise/lungime de undă pentru materialele uzuale

Material	Formula	Wavelength Range λ (μm)	Bandgap Energy W_g (eV)
Indium Phosphide	InP	0.92	1.35
Indium Arsenide	InAs	3.6	0.34
Gallium Phosphide	GaP	0.55	2.24
Gallium Arsenide	GaAs	0.87	1.42
Aluminium Arsenide	AlAs	0.59	2.09
Gallium Indium Phosphide	GaInP	0.64-0.68	1.82-1.94
Aluminium Gallium Arsenide	AlGaAs	0.8-0.9	1.4-1.55
Indium Gallium Arsenide	InGaAs	1.0-1.3	0.95-1.24
Indium Gallium Arsenide Phosphide	InGaAsP	0.9-1.7	0.73-1.35

$$E_g = h\nu; \quad \lambda = \frac{hc}{E_g}; \quad \lambda[\mu\text{m}] = \frac{1.240}{E_g[\text{eV}]}$$

- ▶ h constanta lui Plank
 $6.6261 \cdot 10^{-34} \text{ W s}^2$
- ▶ c viteza luminii **in vid**
 $2.998 \cdot 10^8 \text{ m/s}$
- ▶ e sarcina electronului
 $1.6 \cdot 10^{-19} \text{ C}$
- ▶ benzi energetice: λ_0 , $\Delta\lambda$

LED cu heterojunțiuni – principiu

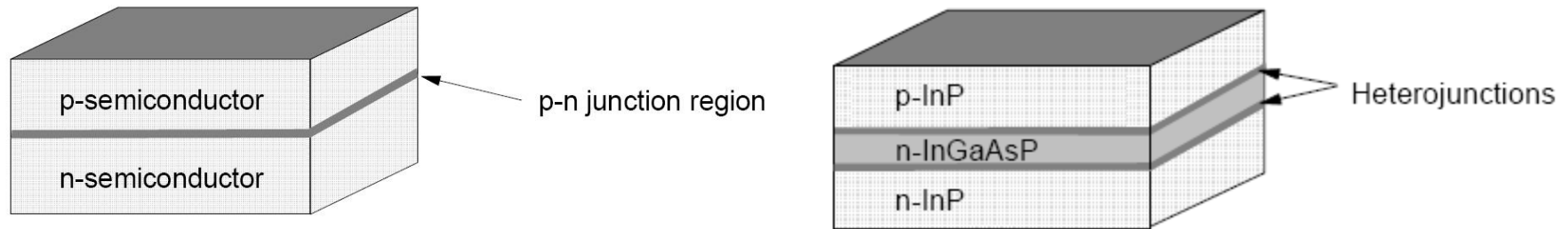

- ▶ **Orice** jonctiune p–n emite lumina
- ▶ O jonctiune p–n obisnuita este foarte subtire
 - volumul in care apar recombinari este foarte mic
 - eficienta luminoasa, redusa
- ▶ lumina este emisa in toate directiile
 - cantitatea de lumina utilizabila (intr–o anumita directie) este redusa

LED cu heterojunțiuni – principiu

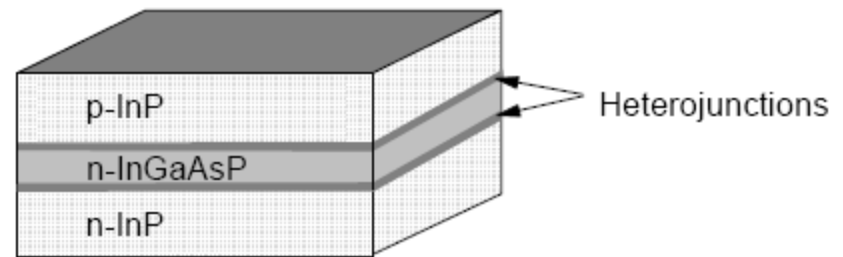
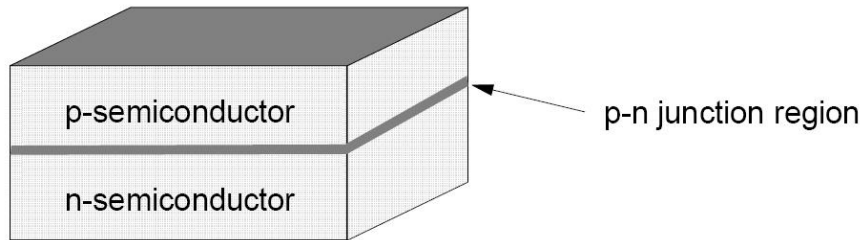

- ▶ Structura de nivele energetice permite capturarea purtătorilor între cele două heterojunțiuni

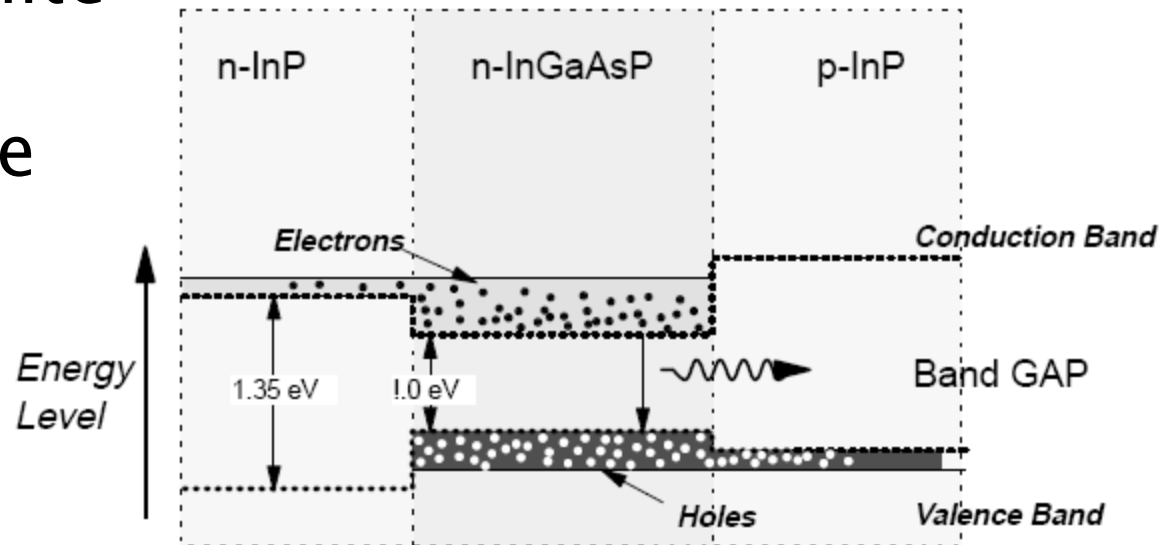

Dependența benzii interzise de constanta rețelei

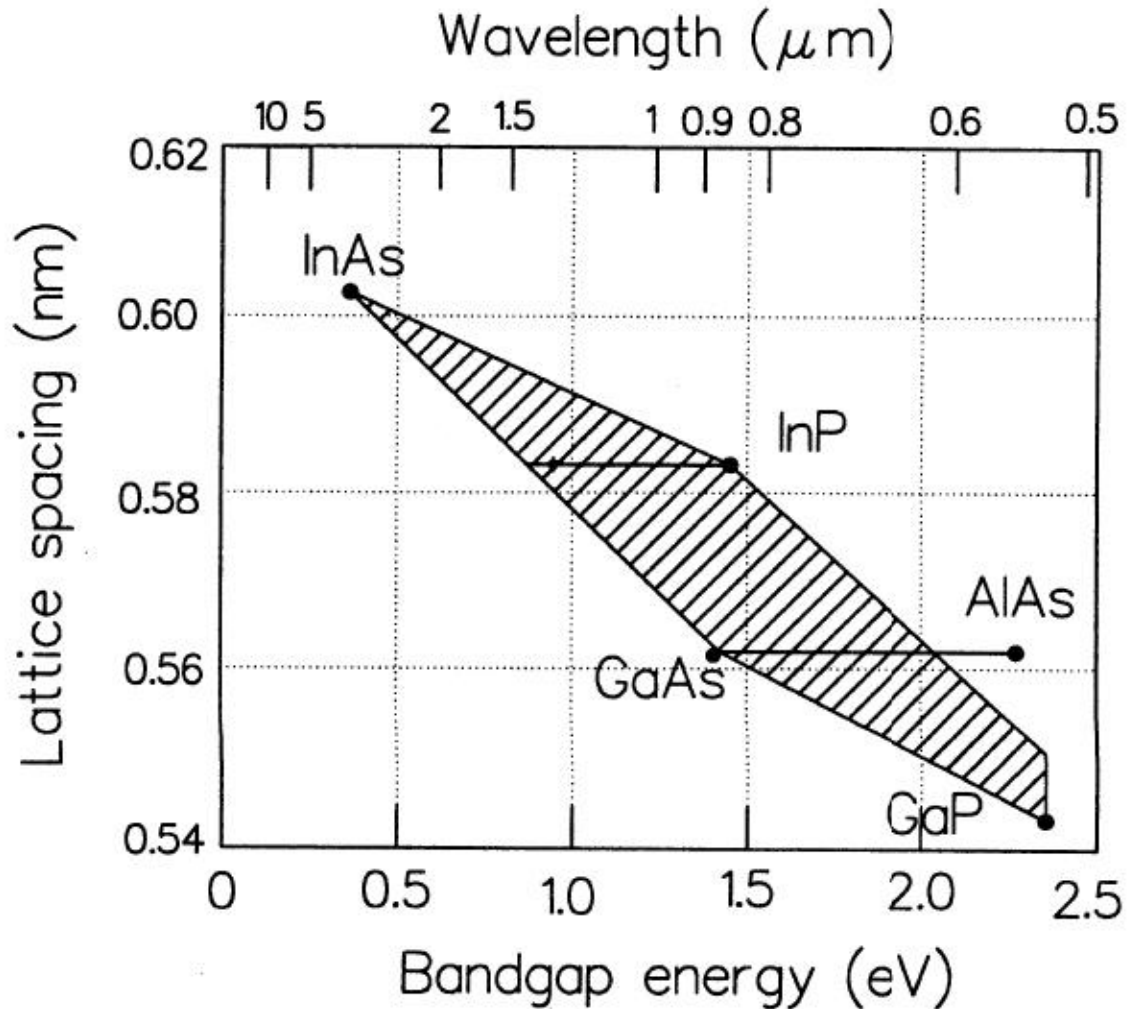
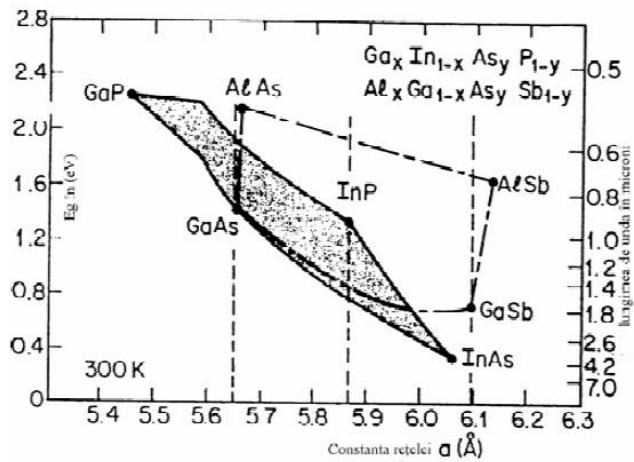

Emisia luminii spre exterior

- ▶ Indici de refractie ridicati
 - InP $n=3.4$
 - GaAs $n=3.6$
- ▶ Doua probleme generate
 - pierderi prin reflexie ridicate
 - unghi critic de numai 15°

Emisia luminii spre exterior

▶ Solutii

- utilizarea unui material intermediar pentru adaptarea indicelui de refractie (rasina epoxidica)
- adaptarea formei de iesire din dispozitiv – forma de dom
 - eficienta de cuplaj

interfata plana
semiconductor
aer $\frac{1}{n \cdot (n+1)^2}$

dom $\frac{2n}{(n+1)^2}$

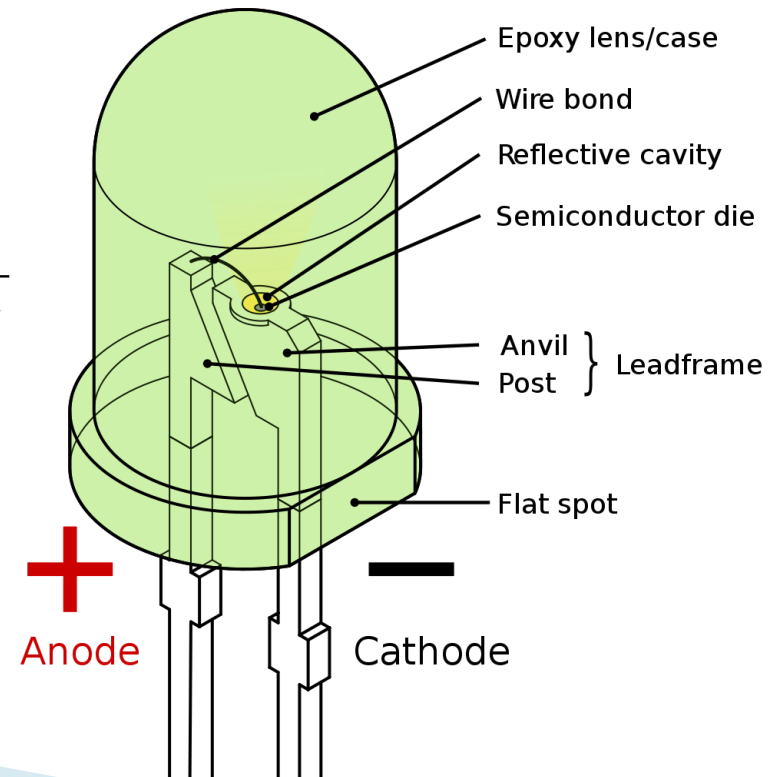

Continuare



Cuplarea luminii în fibră

(a) Grin Lens

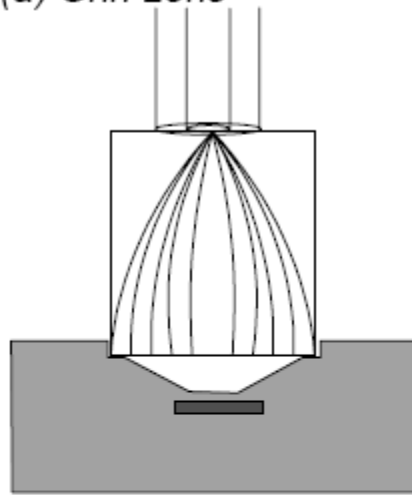

(b) Ball Lens

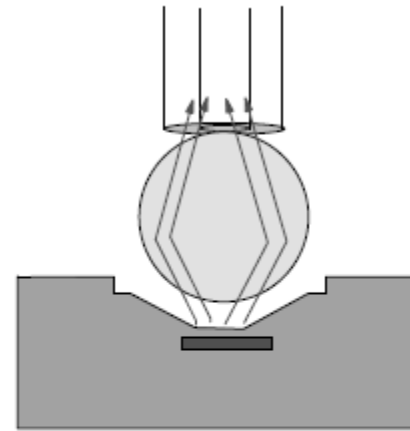

(c) Direct coupling

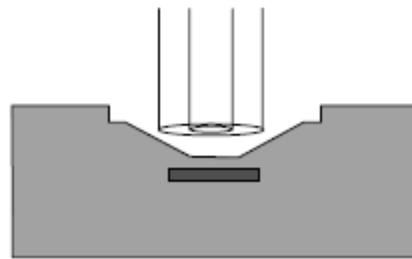

(d) Lensed fibre end

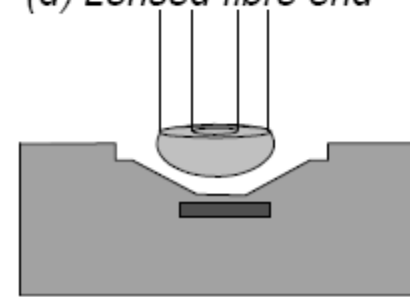

numai pentru fibre multimod cu salt de indice

Directivitatea radiatiei exterioare

- ▶ Sursa lambertiana

$$P(\theta) = P_0 \cdot \cos \theta$$

- ▶ Aproximatie Lambertiana pentru surse cu directivitate crescuta

$$P(\theta) = P_0 \cdot \cos^n \theta$$

- ▶ Surse cu emisie asimetrica

$$P(\theta) = \frac{P_0}{\frac{\sin^2 \phi}{\cos^T \theta} + \frac{\cos^2 \phi}{\cos^L \theta}}$$

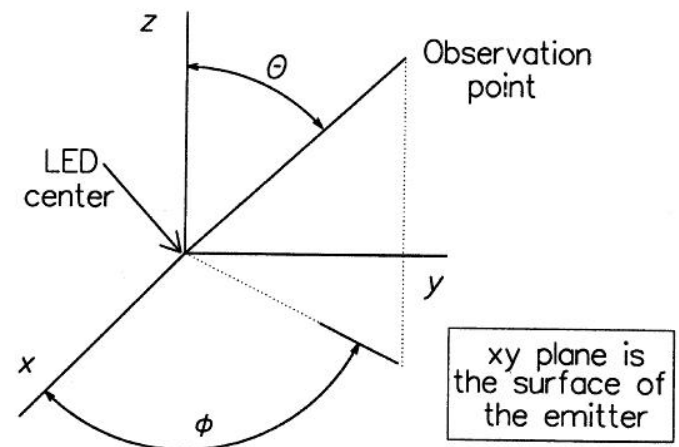
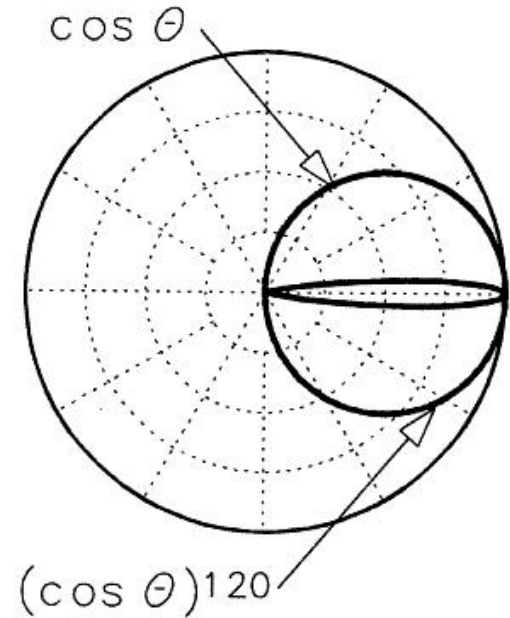

Directivitatea radiatiei exterioare

▶ SLED

- radiatia este emisa cu simetrie circulara, in interiorul unui con cu unghi la varf tipic de 60°
- Viewing Half Angle $\sim 10 \div 15^\circ$

▶ ELED

- radiatia emisa nesimetric in forma de con eliptic
 - perpendicular pe jonctiune $\sim 60^\circ$
 - paralel cu jonctiunea $\sim 30^\circ$

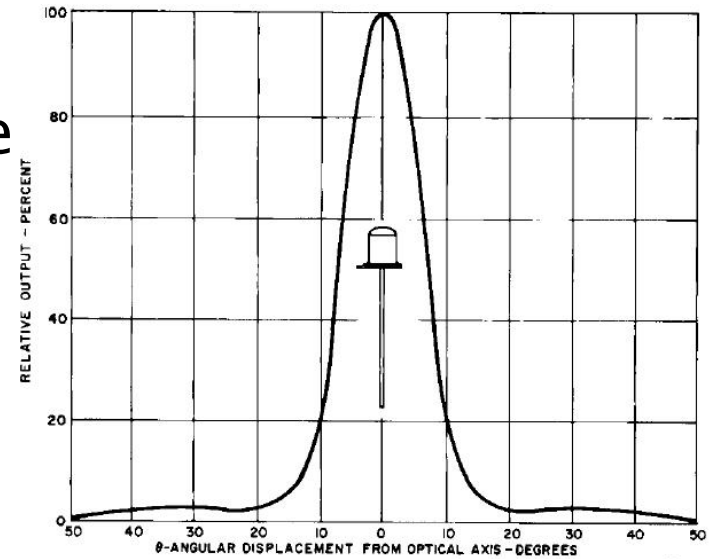
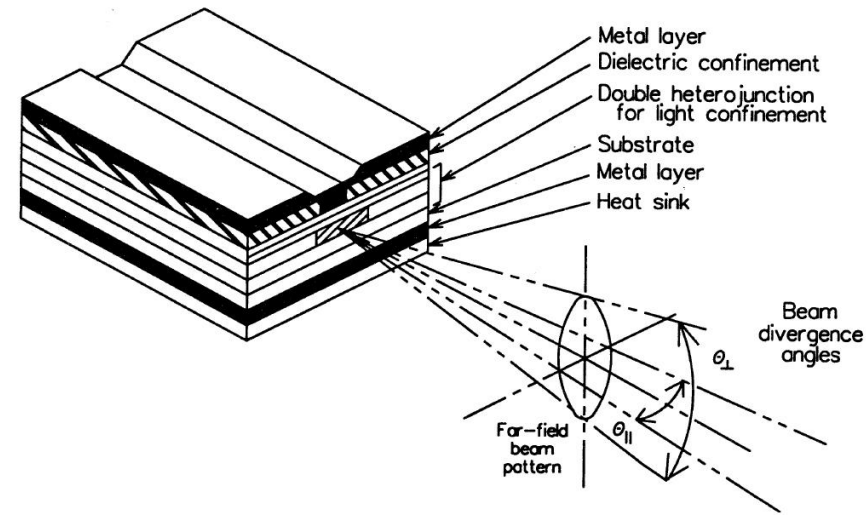
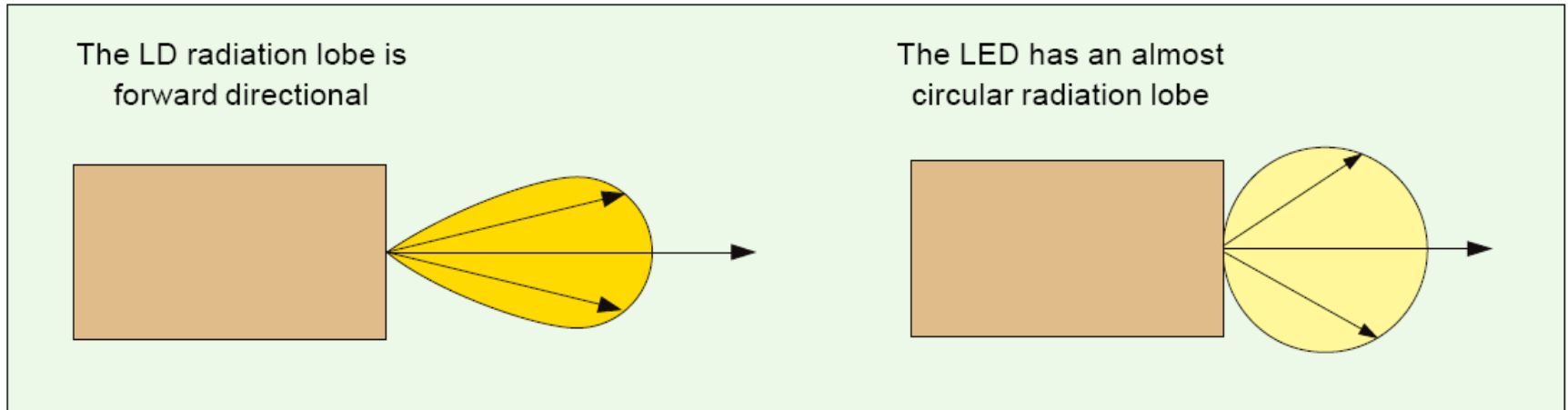

Fig. 5. Typical Radiation Pattern

ST1054



Profil de radiație a emițătorilor optici



- ▶ Apertura numerică poate varia de la 0.9 pentru un LED de unghi foarte larg, la 0.2 pentru un LED prevăzut cu lentilă.
- ▶ Chiar și pentru un NA de 0.2, aria emisivă este mare comparativ cu a unui laser. În consecință, densitatea de putere emisă este mică astfel încât se reduce drastic puterea care poate fi cuplată într-o fibră cu indice gradat, și devine practic imposibilă cuplarea cu o fibră monomod.

Caracteristici putere optică/curent a emițătorilor optici

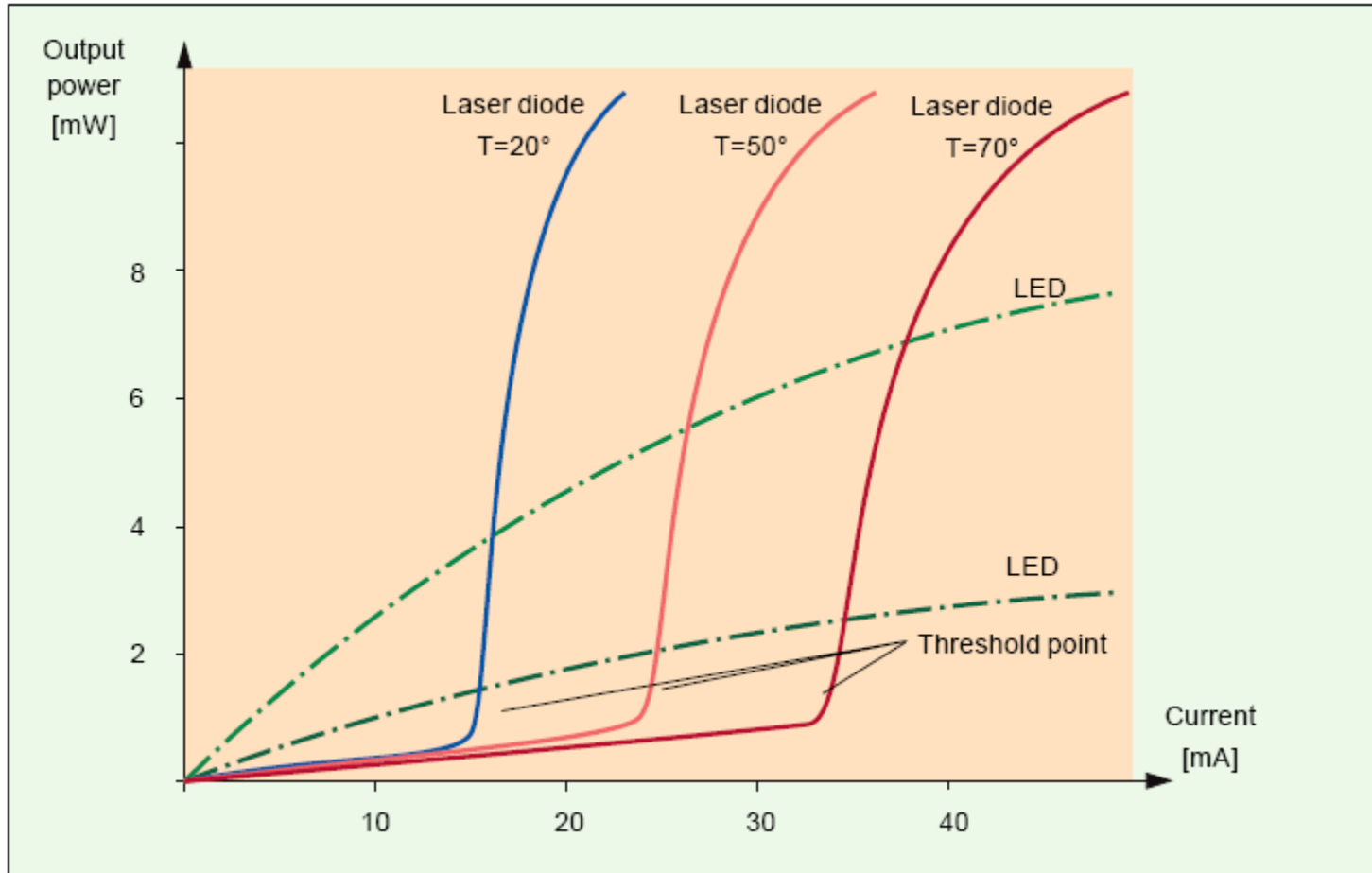

Caracteristica de raspuns a LED-urilor

- ▶ Caracteristica putere optica emisa functie de curentul direct prin LED este liniara la nivele mici ale curentului.
- ▶ Nu exista curent de prag
- ▶ La nivele foarte mari puterea optica se satureaza

- ▶ Responzivitatea

$$r = \frac{P_o}{I} \left[\frac{W}{A} \right]$$

- ▶ Tipic $r = 50 \mu\text{W}/\text{mA}$

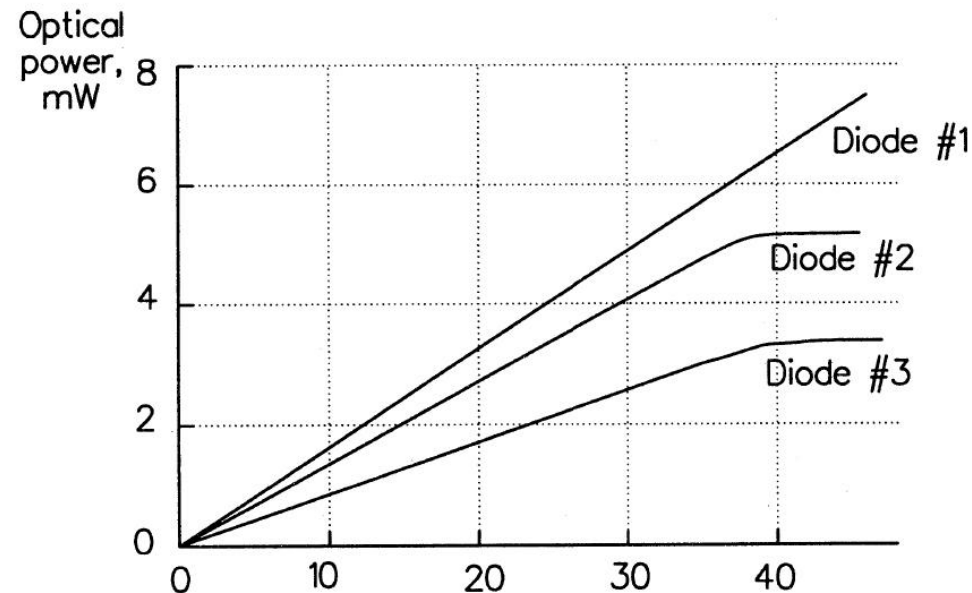

Caracteristica de raspuns a LED-urilor

- ▶ Tipic SLED au eficienta mai buna decat ELED

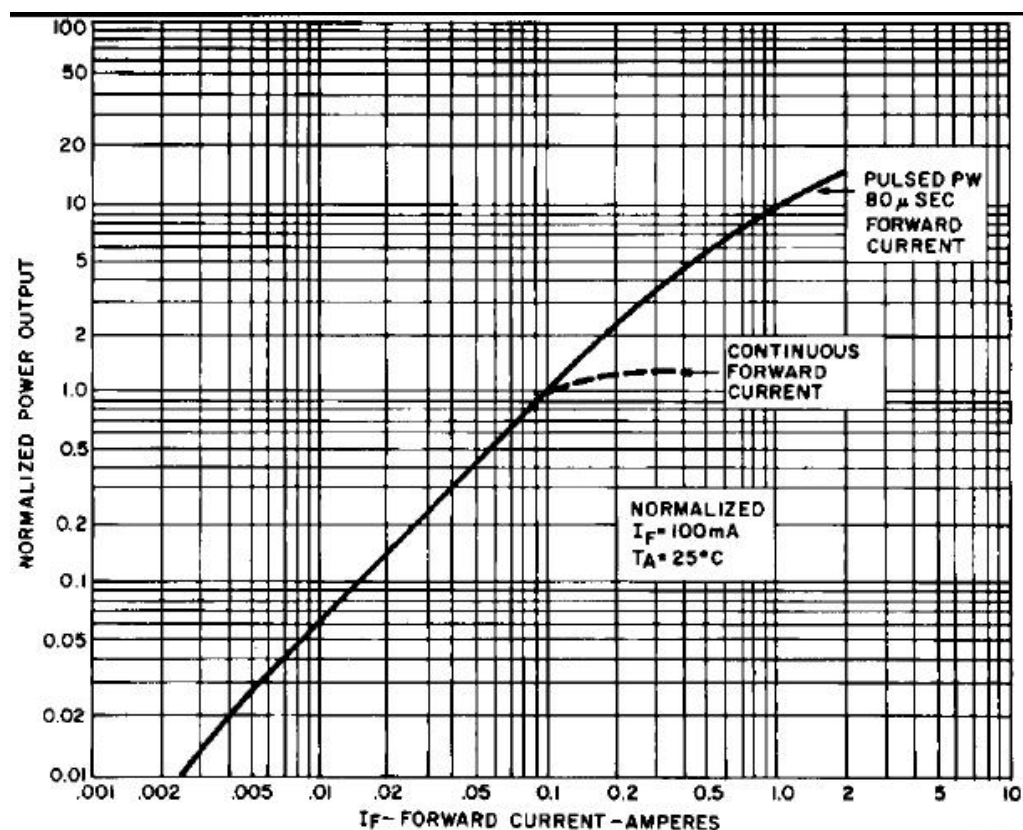
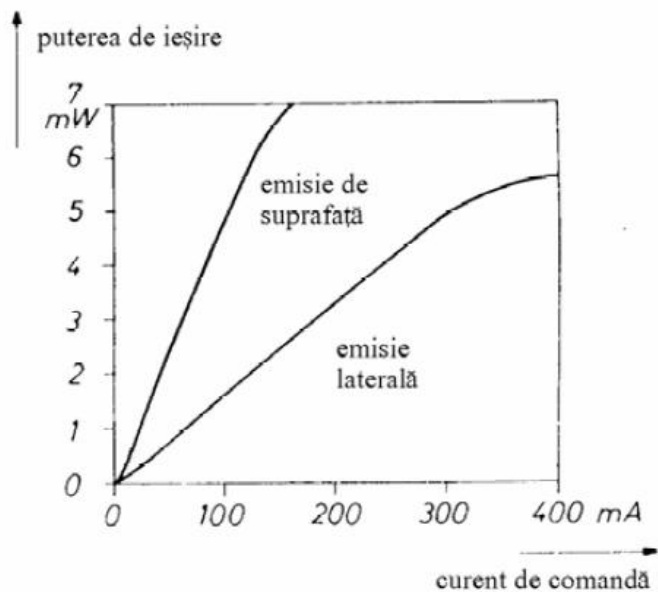

Fig. 1. Power Output vs. Input Current

ST1052

Probleme

- ▶ Un dispozitiv de semnalizare e realizat cu 100 LED-uri care emit lungimea de undă dominantă $\lambda_0 = 590\text{nm}$ sub un con cu unghi la vârf de 5.2° (emisie presupusă **uniformă** în acest con). O diodă are rezonanzivitatea de $90\mu\text{W}/\text{mA}$ și este parcursă de un curent de 85mA .
- ▶ a) Estimați intensitatea luminoasă a dispozitivului pe direcție normală.
- ▶ Dacă se consideră emisia **uniformă** în interiorul conului de emisie, fluxul optic energetic este constant în interiorul acestui con și va fi egal cu puterea optică emisă (ambele mărimi reprezintă viteze ale energiei, măsurate în W, cu diferența că puterea optică reprezintă o medie a fluxurilor emise după diferite direcții, valoarea medie a unei mărimi constante fiind egală cu acea mărime)

Aplicatii majore LED

▶ Comunicatii

- Infrarosu (InGaAsP)

▶ Vizibil

- Spectru vizibil (GaAlAs)

▶ Iluminare

- Putere ridicata, lumina alba (GaInN)

Calitatea spectrală a emițătorilor optici

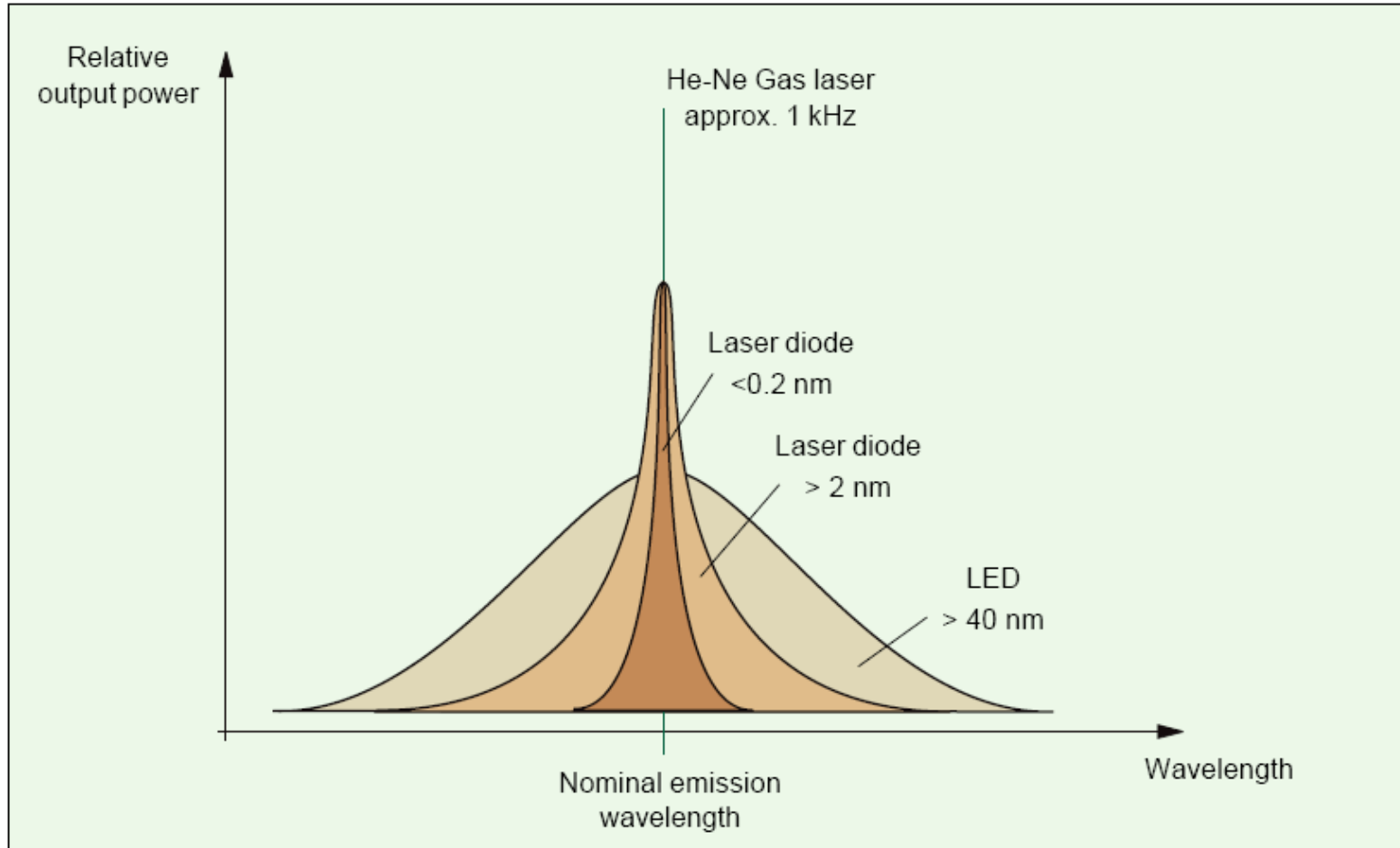

Latimea spectrala a LED-urilor

- ▶ Aproximativ $\Delta\lambda \approx 0.05\lambda$
- ▶ Relatie empirica $\Delta\lambda[\mu m] \approx 1.45\lambda^2[\mu m](kT)[eV]$
- ▶ Tipic
 - GaAlAs – 20–40 nm
 - InGaAsP
 - SLED – 100 nm
 - ELED – 60–80 nm
 - GaInN – 30–40 nm (10%)

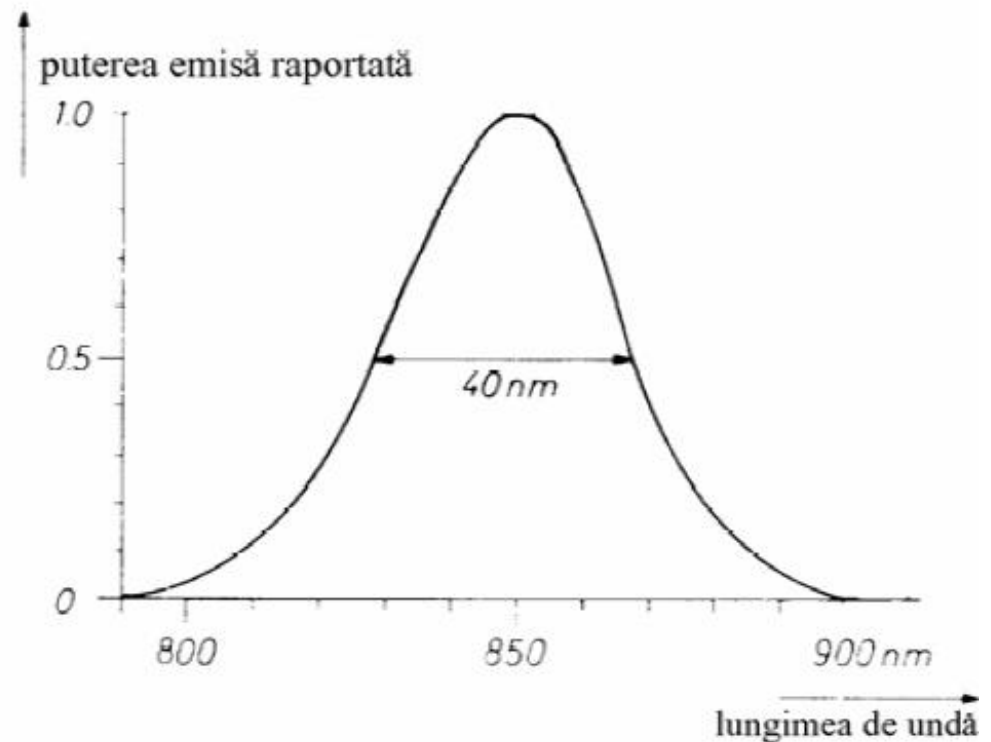

Comportare dinamica a LED

- ▶ Puterea de iesire la modulatia cu un semnal sinusoidal cu ω

$$P_{out} = \frac{P_o}{1 + \omega^2 \tau_{lf}^2}$$

- Puterea electrica variaza proportional cu patratul curentului
- Puterea optica variaza proportional cu curentul
- ▶ Banda la 3 dB electrica

$$\frac{P_{out}^2}{P_o^2} = \frac{1}{2}$$

$$f_{3dB-el} = \frac{1}{2 \cdot \pi \cdot \tau_{lf}}$$

- Banda la 3 dB optic

$$\frac{P_{out}}{P_o} = \frac{1}{2}$$

Comportare dinamica a LED

- ▶ Cand curentul care trece prin dispozitiv e mic timpul de viata al purtatorilor e independent de curent si este dependent liniar de nivelul de dopare in regiunea activa
- ▶ Cand curentul este mare timpul de viata al purtatorilor este proportional cu \sqrt{d} si invers proportional cu \sqrt{J}
- ▶ Banda poate fi crescuta
 - Crescand nivelul de dopare
 - Reducand inaltimea zonei active
 - Crescand densitatea de curent

Comportare dinamica a LED

- ▶ In domeniul timp
- ▶ Timpul de crestere (rise time)

$$t_r = 2.20 \cdot \left(\frac{2 \cdot k \cdot T \cdot C_s}{e \cdot I_p} + \tau_{lf} \right)$$

- ▶ Capacitatea asociata sarcinilor in regiunea activa: 350 ÷ 1000pF
- ▶ Produs Putere × Banda

$$P \times \Delta f = \frac{h \cdot c}{2 \cdot \pi \cdot e \cdot \lambda} \cdot \frac{J}{\tau_{lf}}$$

Aplicatii majore LED

- ▶ Comunicatii
 - Infrarosu (InGaAsP)
- ▶ Vizibil
 - Spectru vizibil (GaAlAs)
- ▶ Iluminare
 - Putere ridicata, lumina alba (GaInN)

Aplicatii in spectru vizibil

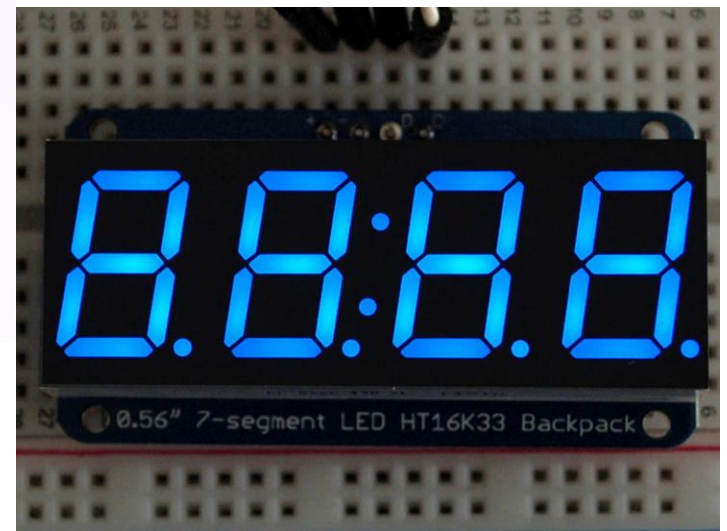
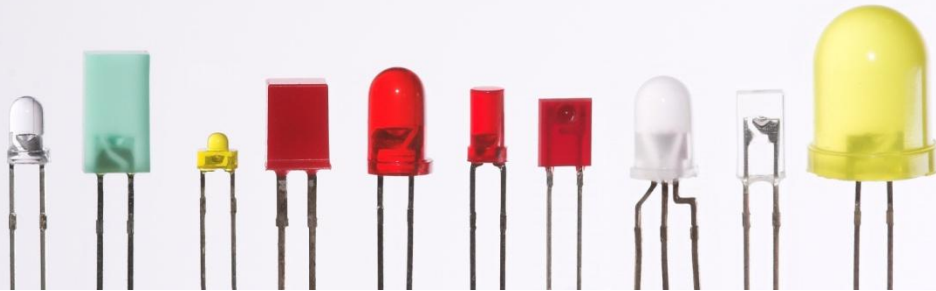
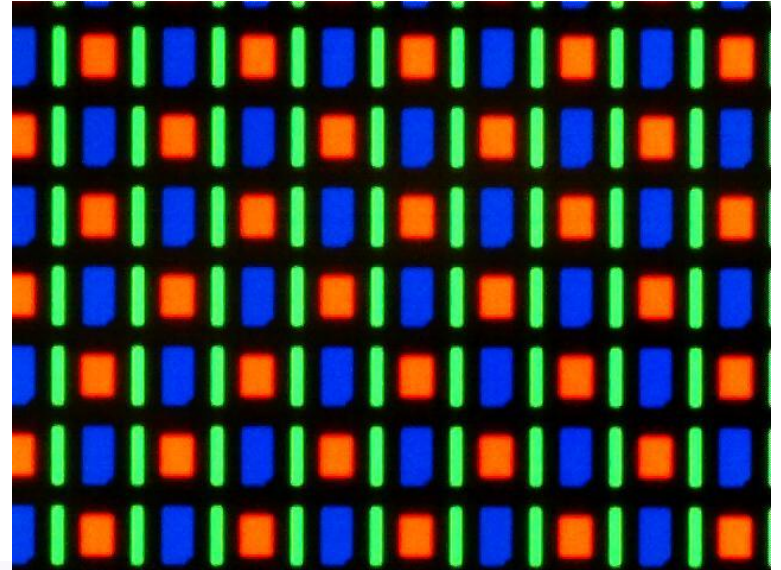

LED albastru

- ▶ bazat pe GaInN
- ▶ dezvoltare tardiva (GaN)

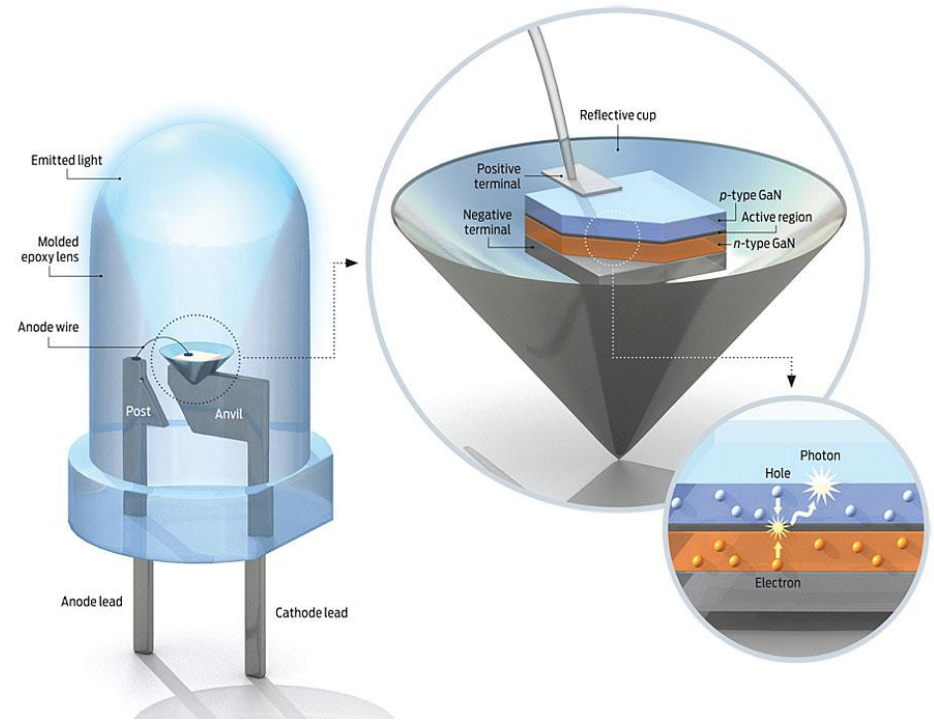
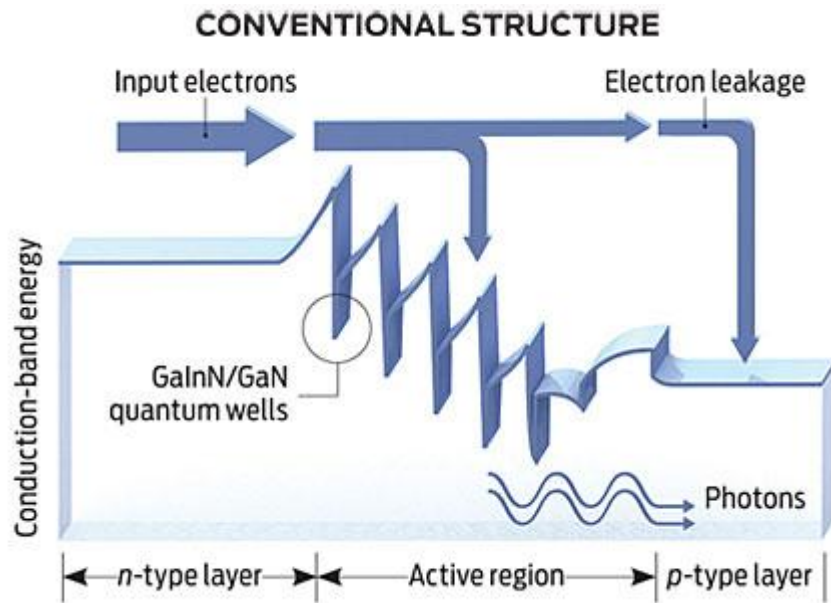

LED albastru

- ▶ realizare: GaInN Quantum Well/GaN

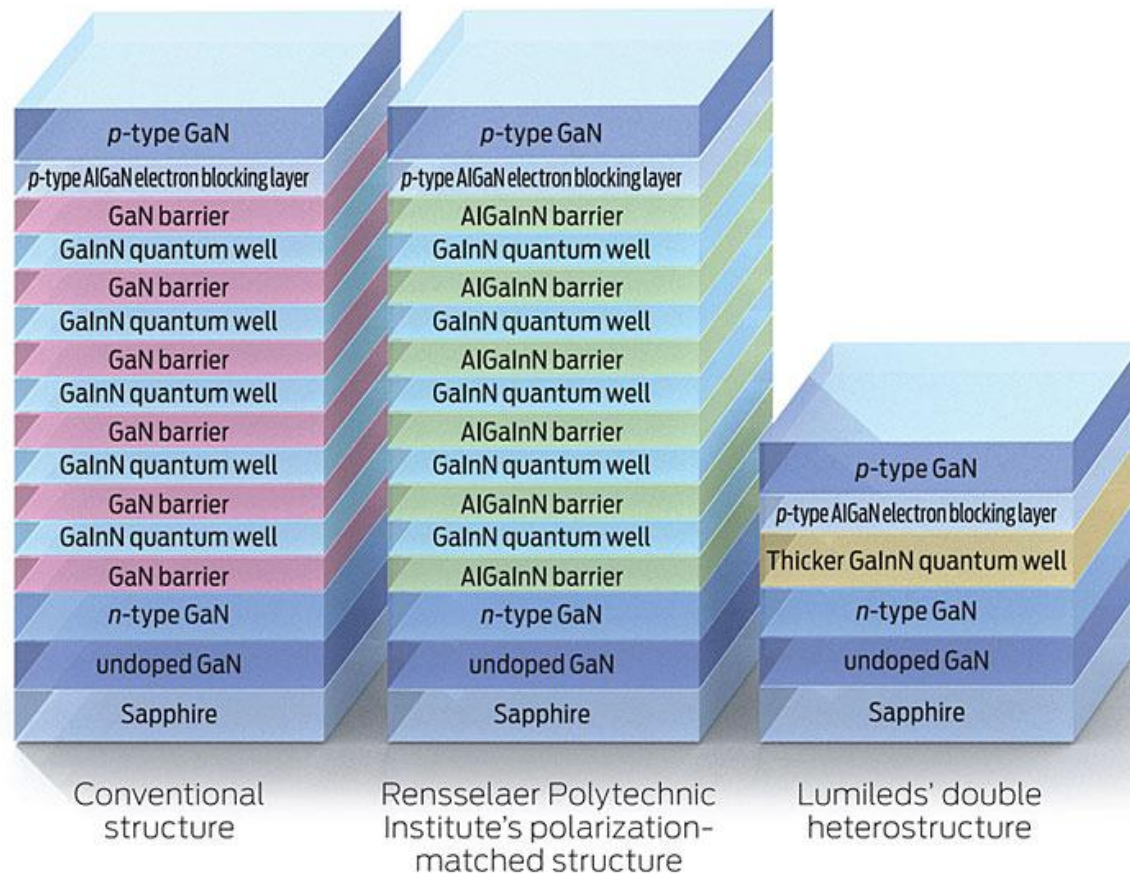

Spectru LED albastru

- ▶ $\Delta\lambda$ relativ la λ mai mare

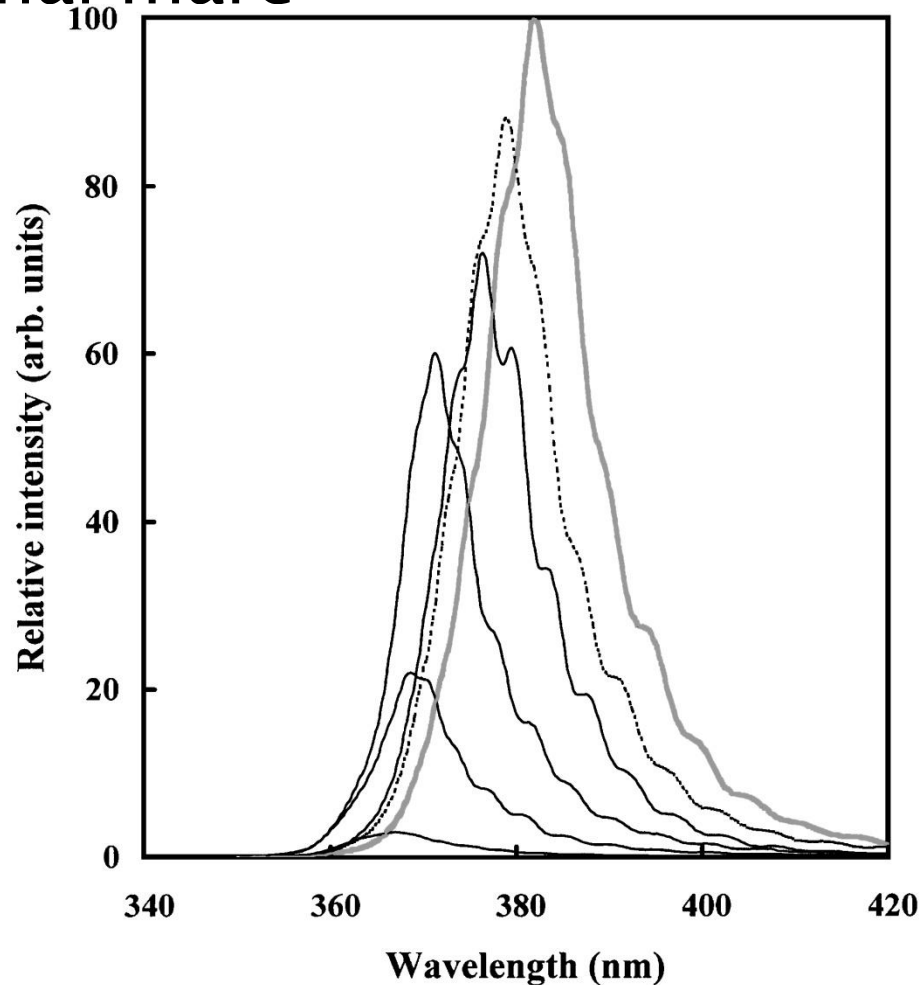

Eficiencia cuantica

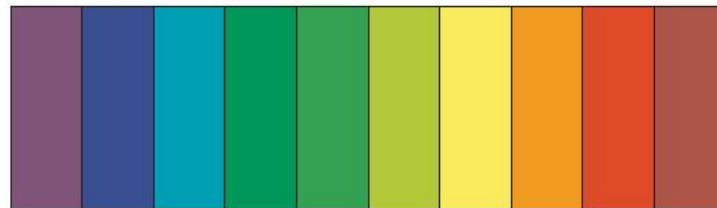
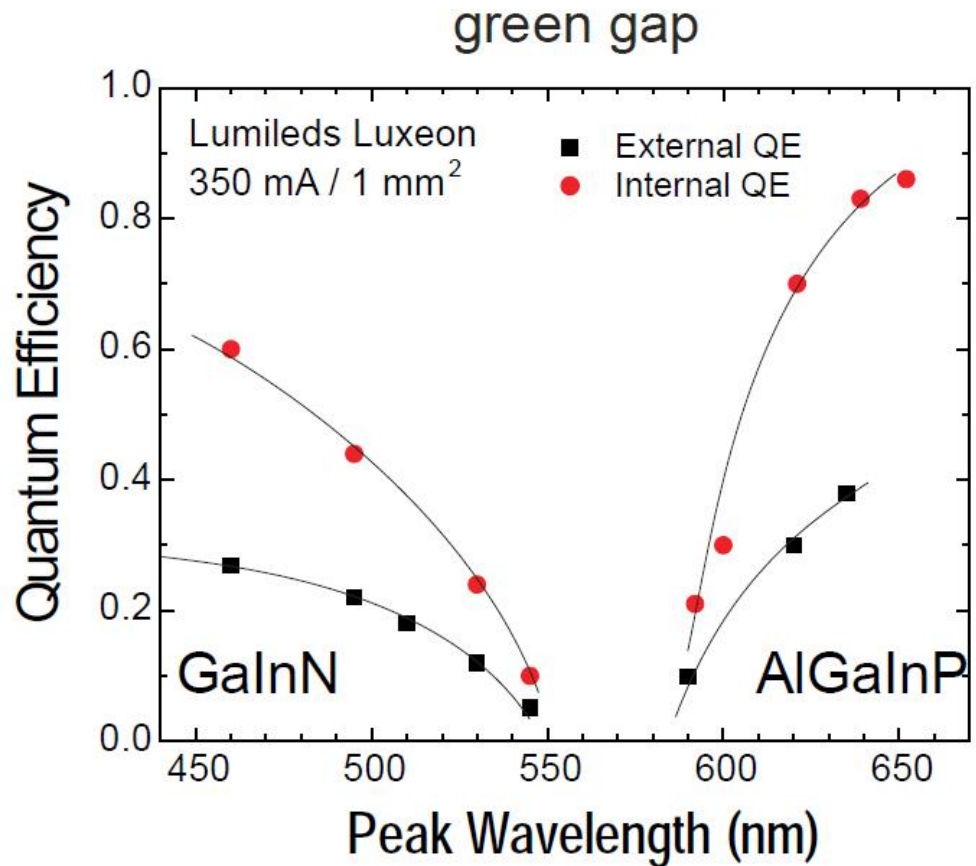

Culori/materiale - 1

Color	Wavelength (nm)	Voltage (V)	Semiconductor Material
Infrared	$\lambda > 760$	$\Delta V < 1.9$	Gallium arsenide (GaAs) Aluminium gallium arsenide (AlGaAs)
Red	$610 < \lambda < 760$	$1.63 < \Delta V < 2.03$	Aluminium gallium arsenide (AlGaAs) Gallium arsenide phosphide (GaAsP) Aluminium gallium indium phosphide (AlGaInP) Gallium(III) phosphide (GaP)
Orange	$590 < \lambda < 610$	$2.03 < \Delta V < 2.10$	Gallium arsenide phosphide (GaAsP) Aluminium gallium indium phosphide (AlGaInP) Gallium(III) phosphide (GaP)
Yellow	$570 < \lambda < 590$	$2.10 < \Delta V < 2.18$	Gallium arsenide phosphide (GaAsP) Aluminium gallium indium phosphide (AlGaInP) Gallium(III) phosphide (GaP)
Green	$500 < \lambda < 570$	$1.9 < \Delta V < 4.0$	Indium gallium nitride (InGaN) / Gallium(III) nitride (GaN) Gallium(III) phosphide (GaP) Aluminium gallium indium phosphide (AlGaInP) Aluminium gallium phosphide (AlGaP)

Culori/materiale - 2

Color	Wavelength (nm)	Voltage (V)	Semiconductor Material
Blue	$450 < \lambda < 500$	$2.48 < \Delta V < 3.7$	Zinc selenide (ZnSe) Indium gallium nitride (InGaN) Silicon carbide (SiC) as substrate Silicon (Si) as substrate — (under development)
Violet	$400 < \lambda < 450$	$2.76 < \Delta V < 4.0$	Indium gallium nitride (InGaN)
Purple	multiple types	$2.48 < \Delta V < 3.7$	Dual blue/red LEDs, blue with red phosphor, or white with purple plastic
Ultraviolet	$\lambda < 400$	$3.1 < \Delta V < 4.4$	Diamond (235 nm) Boron nitride (215 nm) Aluminium nitride (AlN) (210 nm) Aluminium gallium nitride (AlGaInN) — (down to 210 nm)
White	Broad spectrum	$\Delta V = 3.5$	Blue/UV diode with yellow phosphor

Denumiri tipice – LED



Wavelength (nm)	Color Name
940	Infrared
880	Infrared
850	Infrared
660	Ultra Red
635	High Eff. Red
633	Super Red
620	Super Orange
612	Super Orange
605	Orange
595	Super Yellow
592	Super Pure Yellow
585	Yellow
4500K	"Incandescent" White
6500K	Pale White
8000K	Cool White
574	Super Lime Yellow
570	Super Lime Green
565	High Efficiency Green
560	Super Pure Green
555	Pure Green
525	Aqua Green
505	Blue Green
470	Super Blue
430	Ultra Blue

Aplicatii majore LED

- ▶ Comunicatii
 - Infrarosu (InGaAsP)
- ▶ Vizibil
 - Spectru vizibil (GaAlAs)
- ▶ Illuminare
 - Putere ridicata, lumina alba (GaN)

Premiul Nobel, Fizica, 2014



The image is a graphic announcement for the Nobel Prize in Physics 2014. It features a blue background with white and gold text. At the top left is a gold Nobel Prize medal icon. The text 'Nobelpriset i fysik 2014' is written in white, and 'The Nobel Prize in Physics 2014' is written in blue. The Royal Swedish Academy of Sciences logo is in the top right. Three portraits of the laureates are shown in the center, with their names and affiliations below them. A Swedish and English citation is at the bottom, along with the date '2014-10-07' and the academy's name.

Nobelpriset i fysik 2014

The Nobel Prize in Physics 2014

KUNGL. VETENSKAPS AKADEMIEN
THE ROYAL SWEDISH ACADEMY OF SCIENCES



Isamu Akasaki
Meijo University, Nagoya, Japan
Nagoya University, Japan



Hiroshi Amano
Nagoya University, Japan



Shuji Nakamura
University of California,
Santa Barbara, CA, USA

"För uppfinningen av effektiva blå lysdioder vilka möjliggjort ljusstarka och energisnåla vita ljuskällor"

"For the invention of efficient blue light-emitting diodes which has enabled bright and energy-saving white light sources"

2014-10-07

© Kungl. Vetenskapsakademien

Eficiența

- ▶ Bec cu incandescenta
 - 16 lm/W
- ▶ Tub fluorescent
 - 100 lm/W
- ▶ LED
 - curent: 250 lm/W
 - curand: 300 lm/W

Eficienta in timp

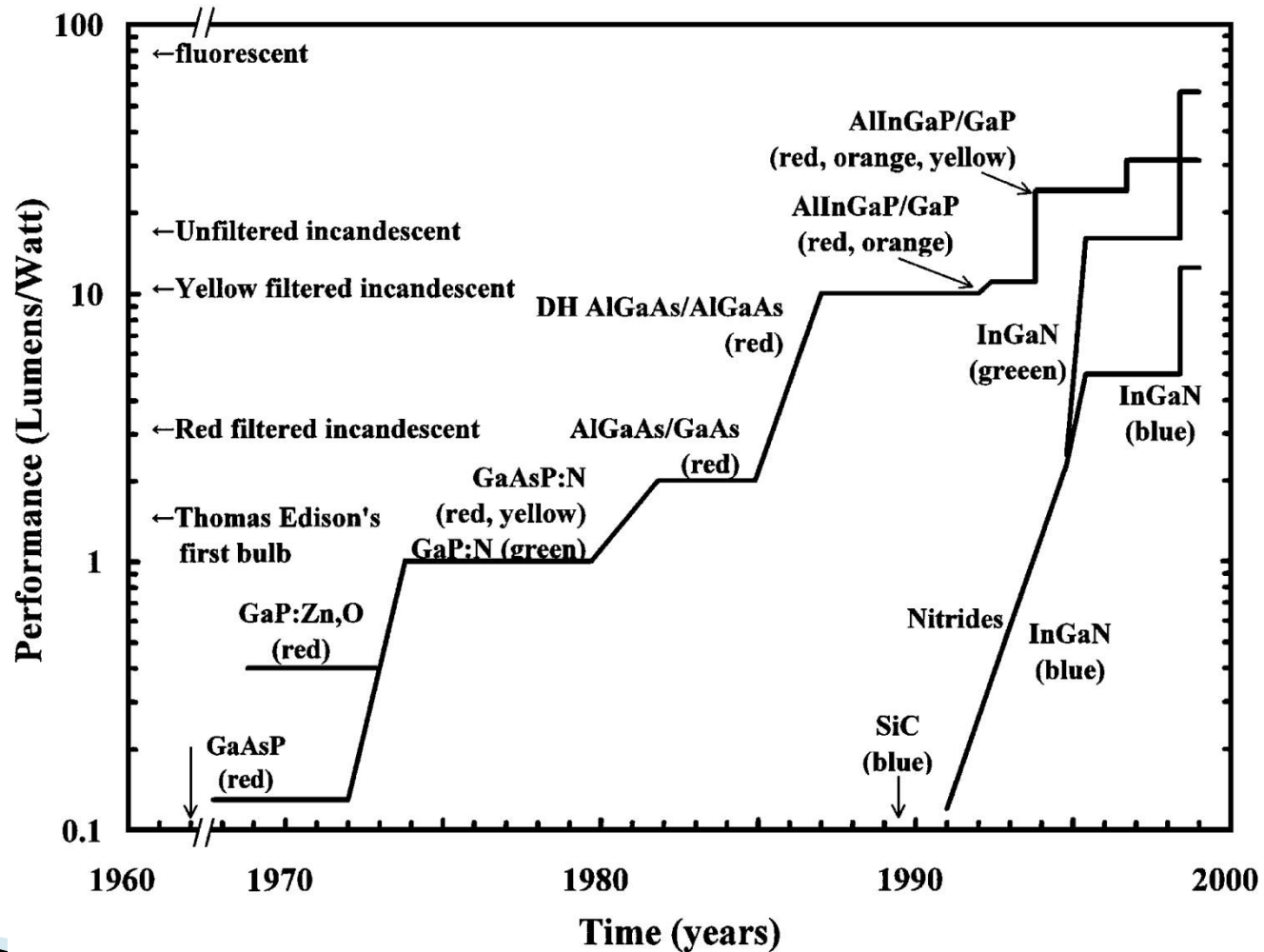

Eficienta in timp

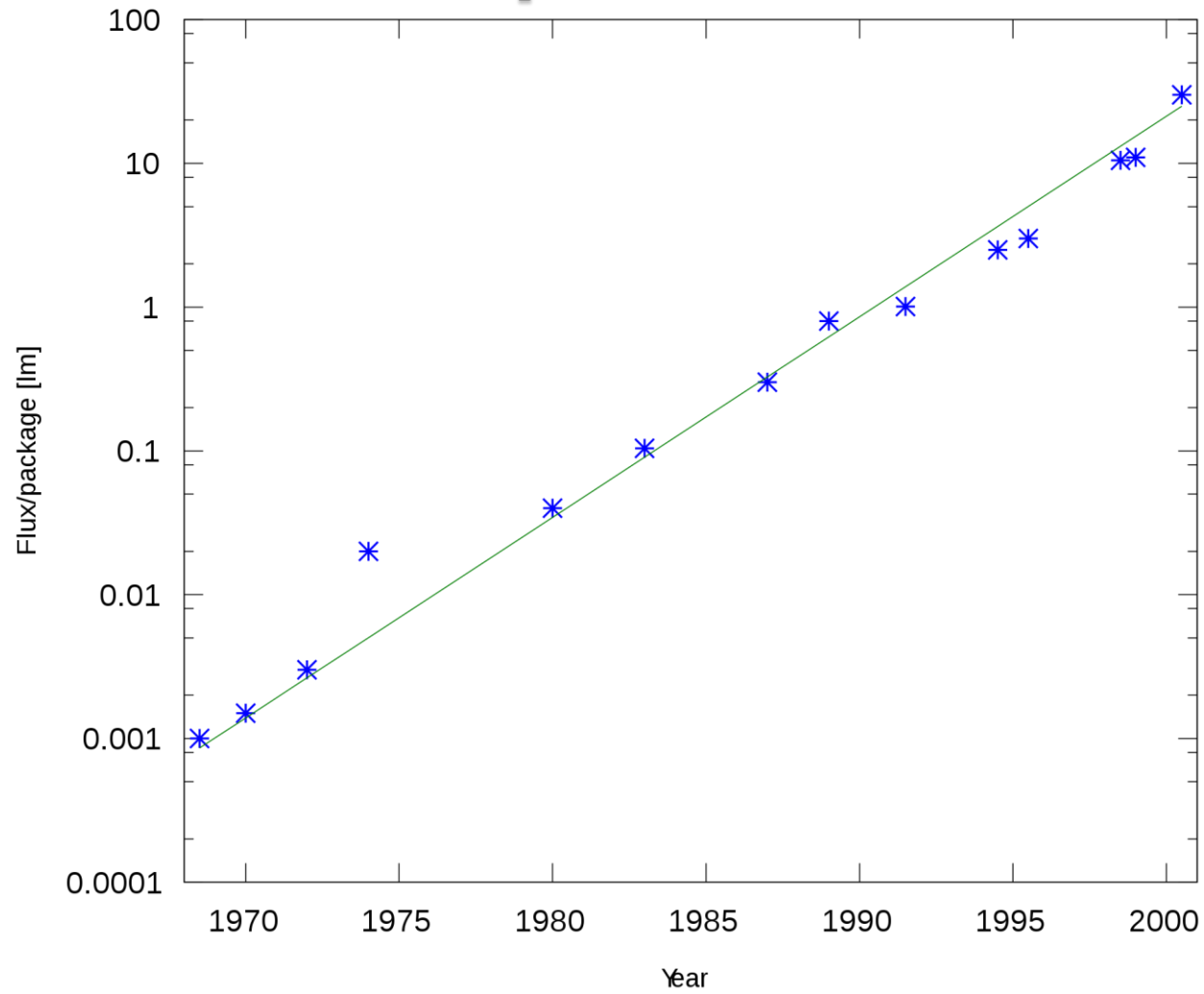

Culoare alba

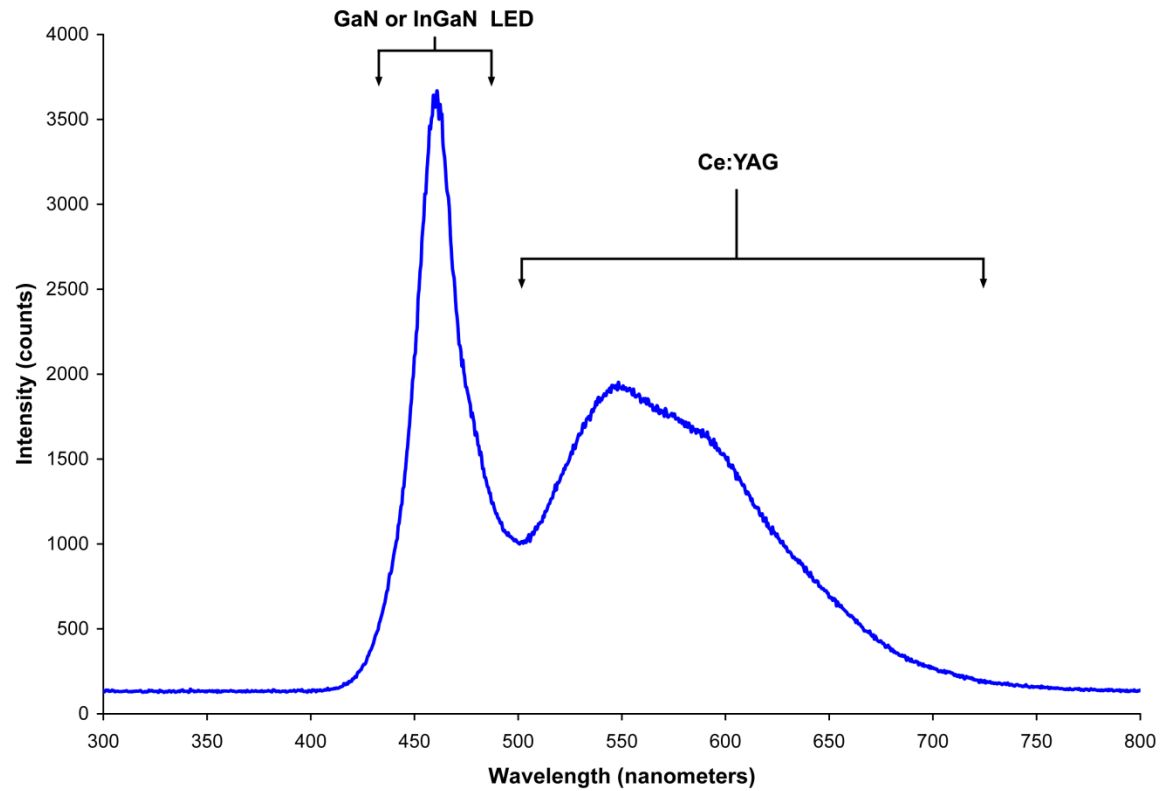
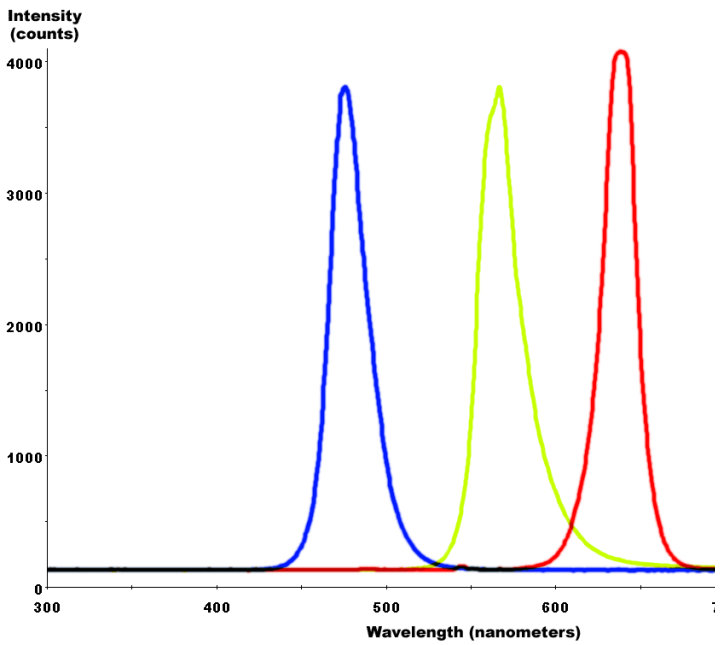

Fosfor activat de LED albastru/UV

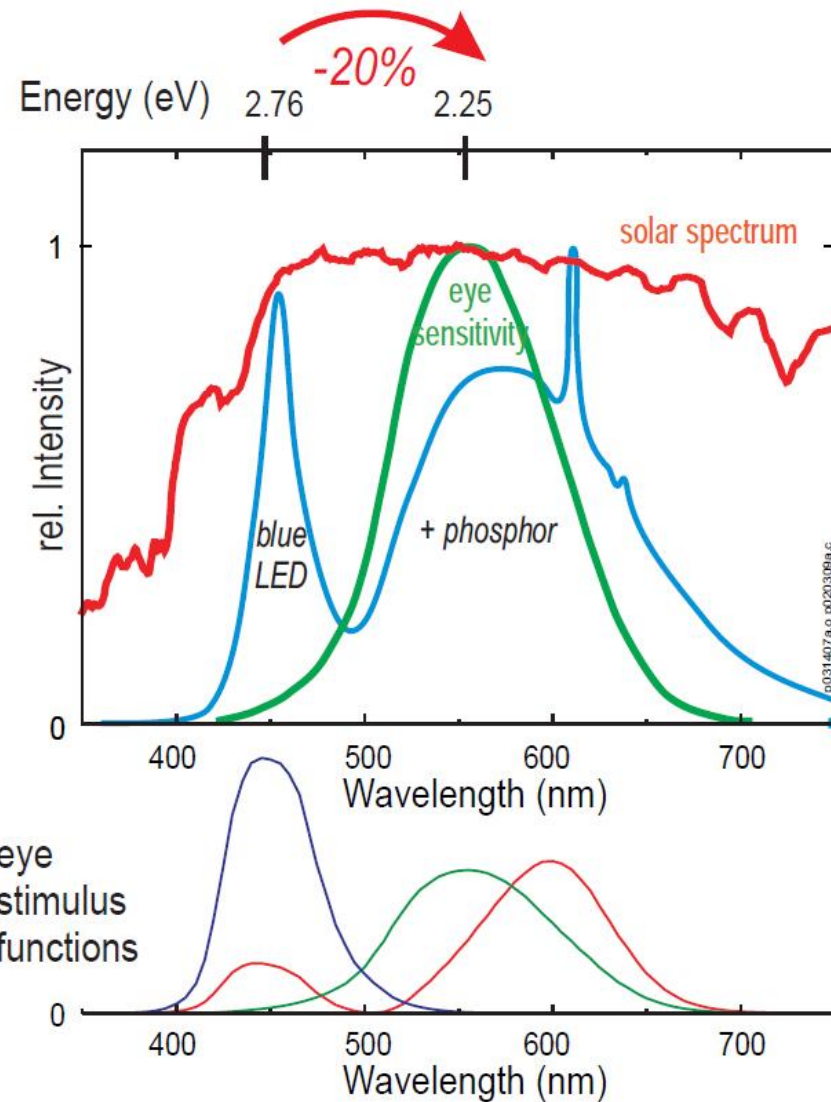

Realizare LED de putere

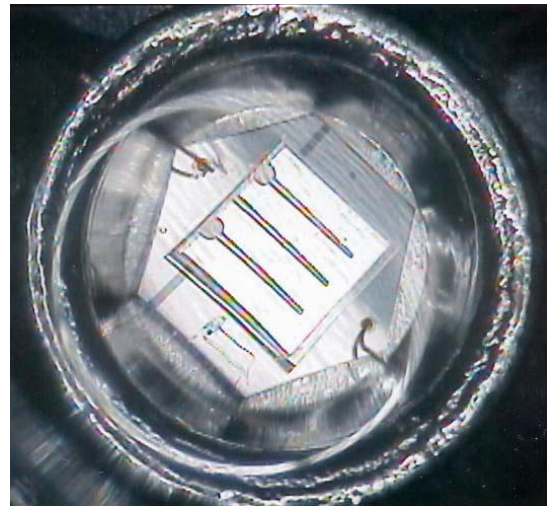
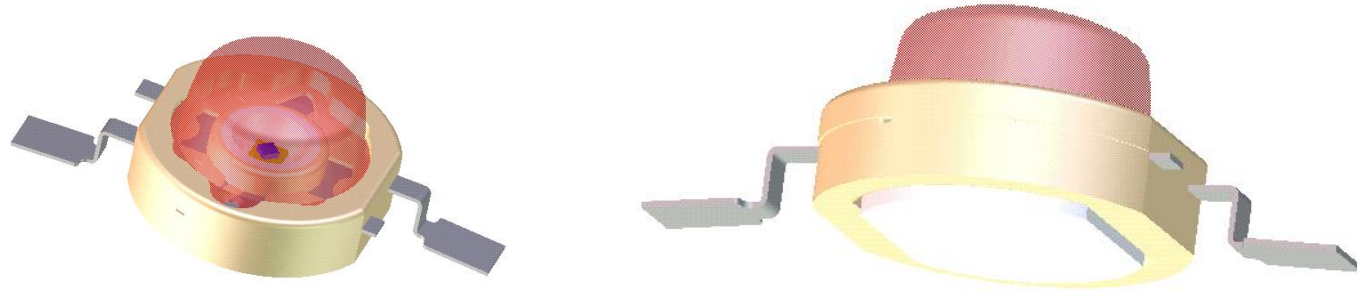

Realizare LED de putere

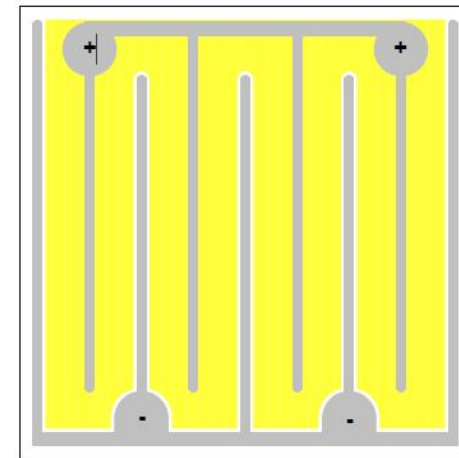
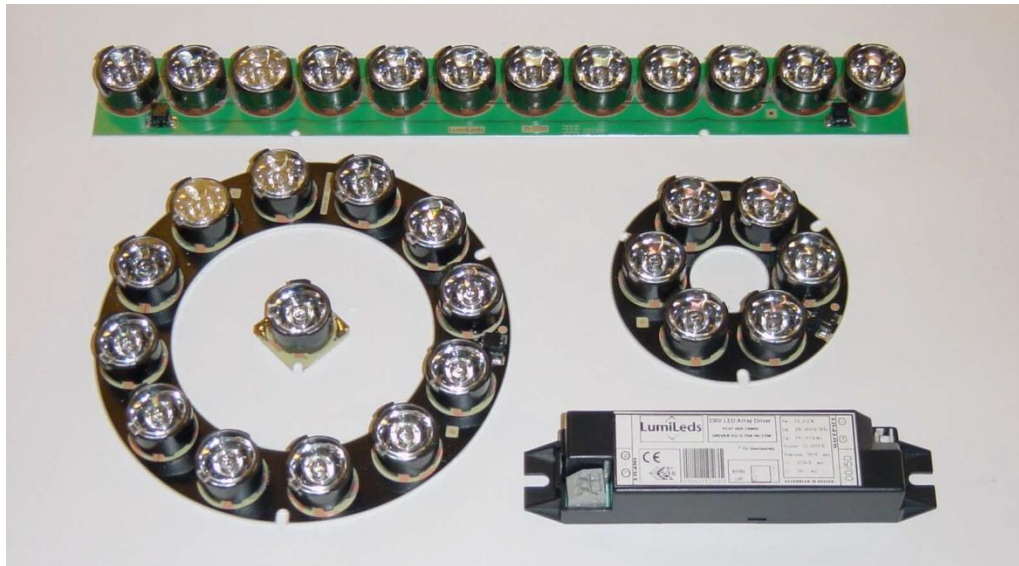

$A_{\text{chip}} \sim 1 \times 1 \text{ mm}^2$; $N = 4$

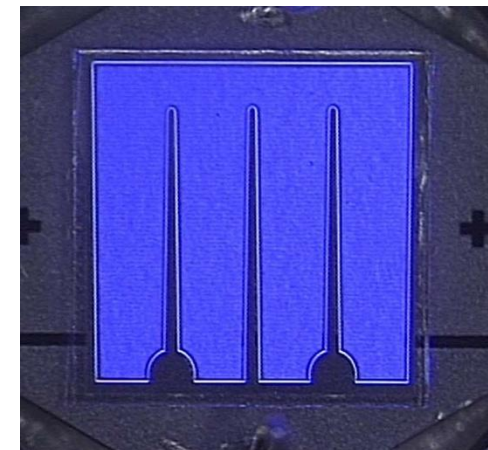
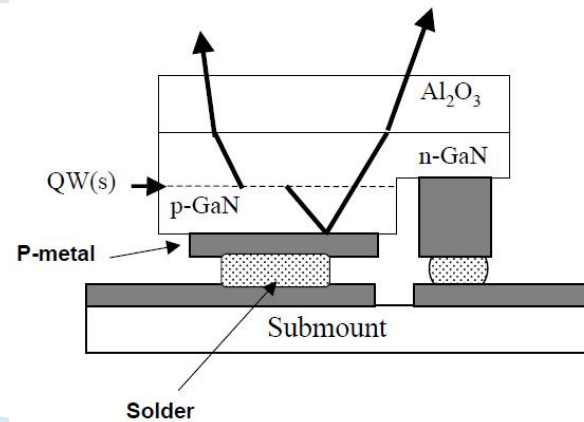

Performanta

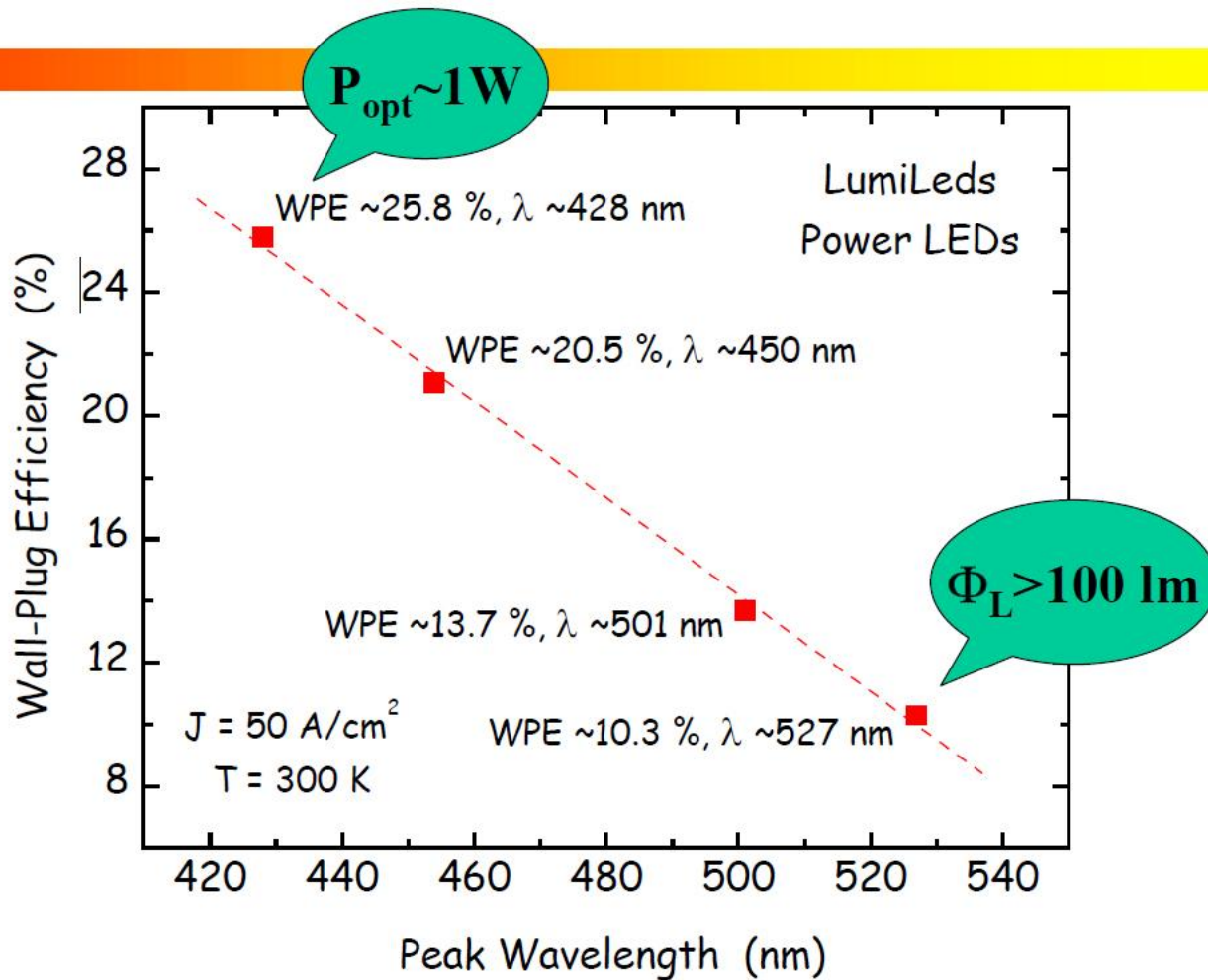

Aplicatii

- ▶ auto



Aplicatii

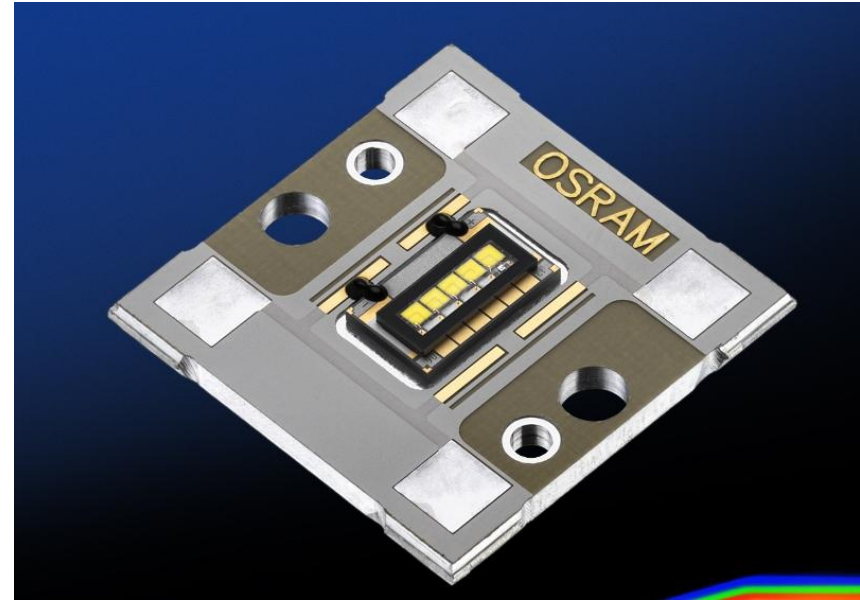

Avantaje

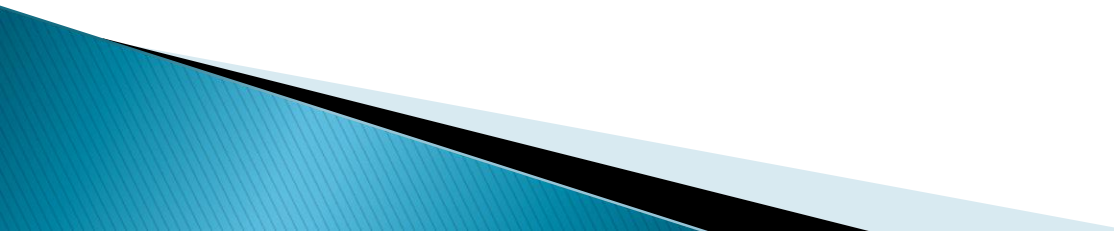
- ▶ Eficienta
 - ▶ Culoare usor de implementat (nativ)
 - ▶ Dimensiune
 - ▶ Timp de raspuns
 - ▶ Reglaj al intensitatii luminoase
 - ▶ Radiatie de caldura (IR) redusa
 - ▶ Timp de viata
 - ▶ Rezistenta la socuri
 - ▶ Directivitatea luminii (nativ)
- 

Dezavantaje

- ▶ Pret
- ▶ Dependenta de temperatura
- ▶ Sensibilitate la tensiune (prag)
- ▶ Calitatea luminii (corp negru)
- ▶ Directivitate (sursa de suprafata/punctuala)

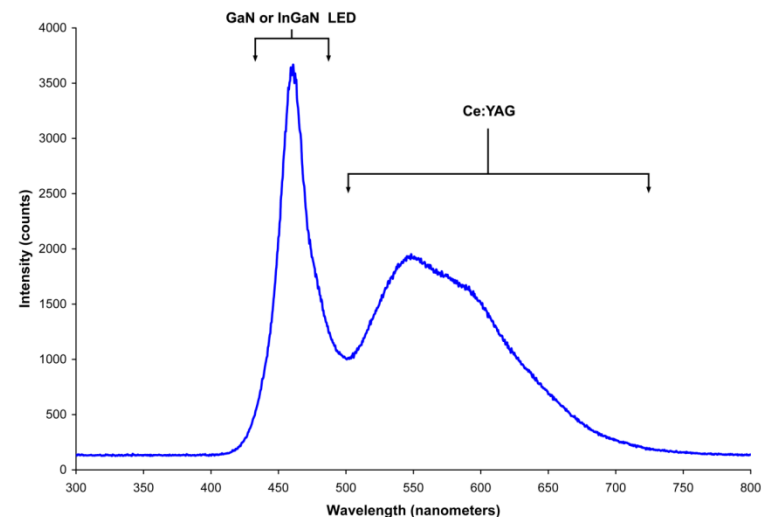
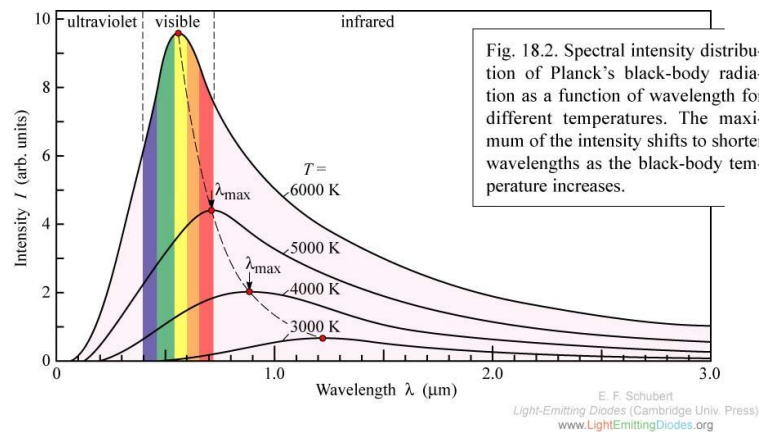

OLED

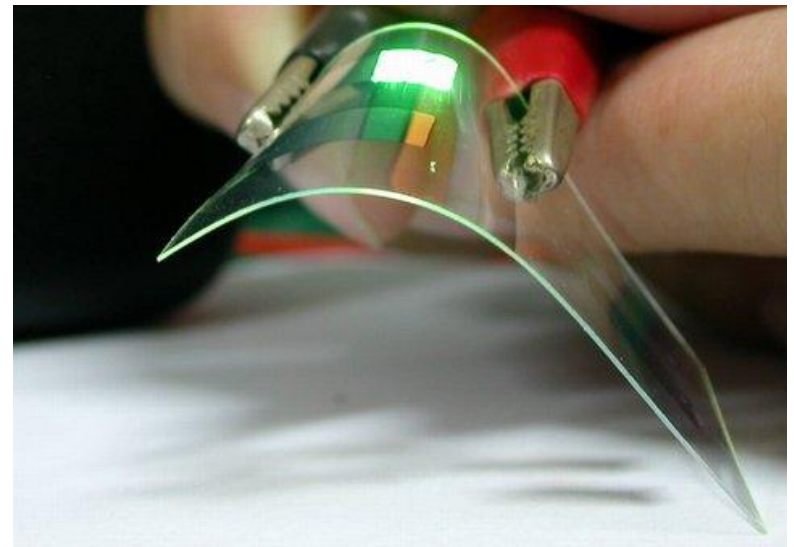
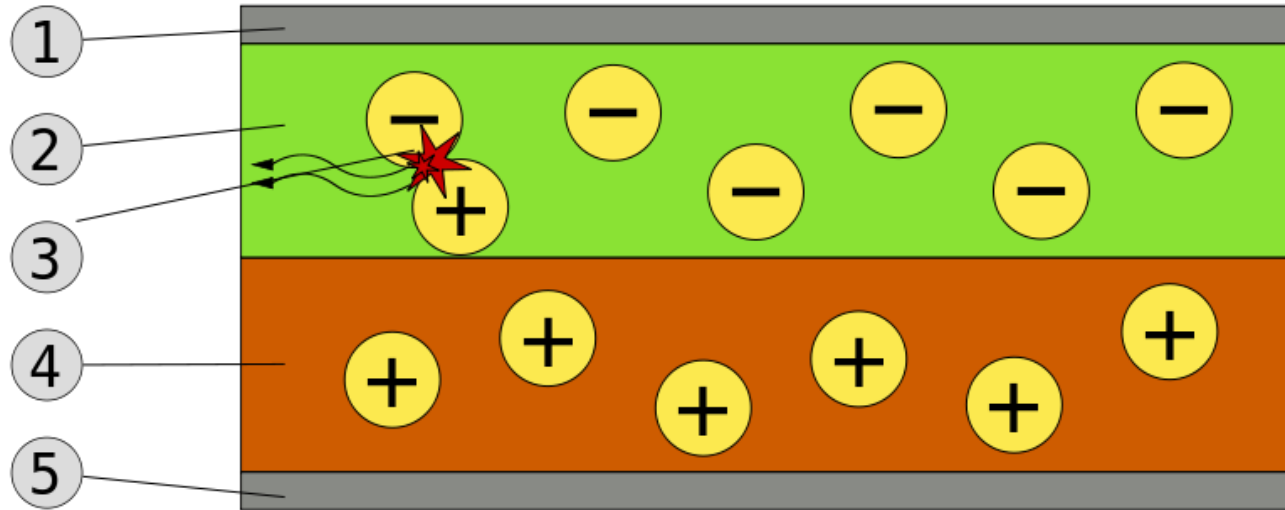

AMOLED

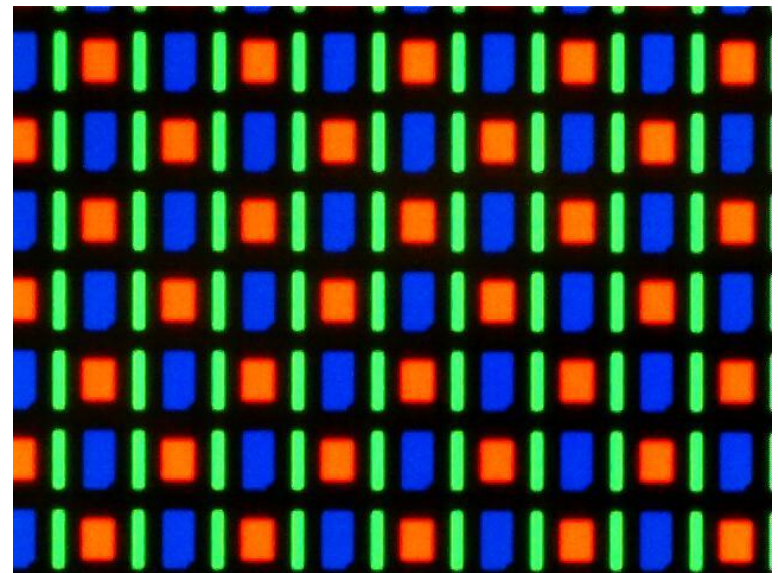
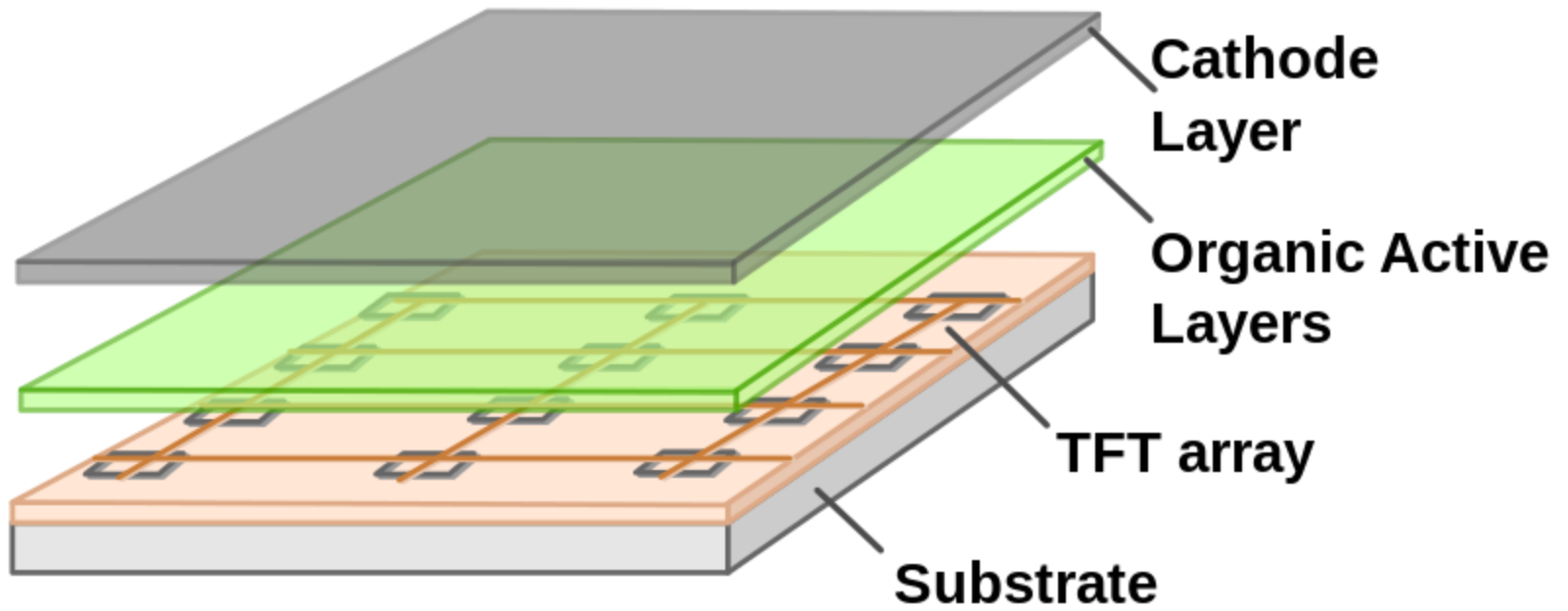

Caracteristica de raspuns a LED-urilor

- ▶ Caracteristica putere optica emisa functie de curentul direct prin LED este liniara la nivele mici ale curentului.
- ▶ Nu exista curent de prag
- ▶ La nivele foarte mari puterea optica se satureaza

- ▶ Responzivitatea

$$r = \frac{P_o}{I} \left[\frac{W}{A} \right]$$

- ▶ Tipic $r = 50 \mu\text{W}/\text{mA}$

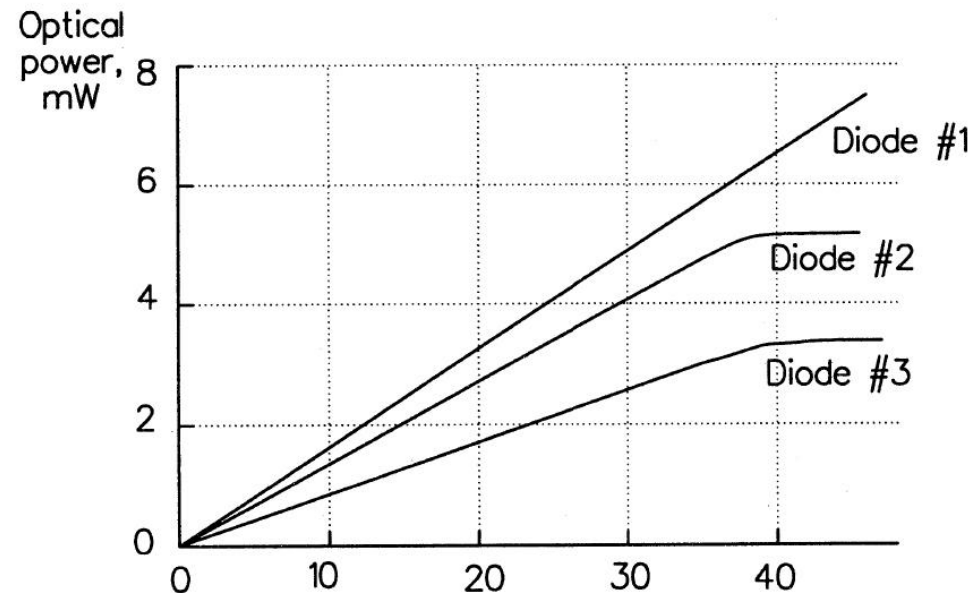

Control static LED

▶ Cea mai simpla schema de control: un rezistor in serie cu LED

- **Atentie!** Tensiunea directa poate varia semnificativ ($\gg 0.7V$) si trebuie preluata din catalog
 - mai ales la intensitate luminoasa mare
 - datorita materialelor diferite de realizare a LED-urilor
 - dependenta de lungimea de unda
 - mai mica la lungimi de unda mai mari

$$I_v = f(I_F [\text{mA}]) \quad [\text{cd/mcd}]$$

$$I_F = \frac{V_{cc} - V_F}{R}$$

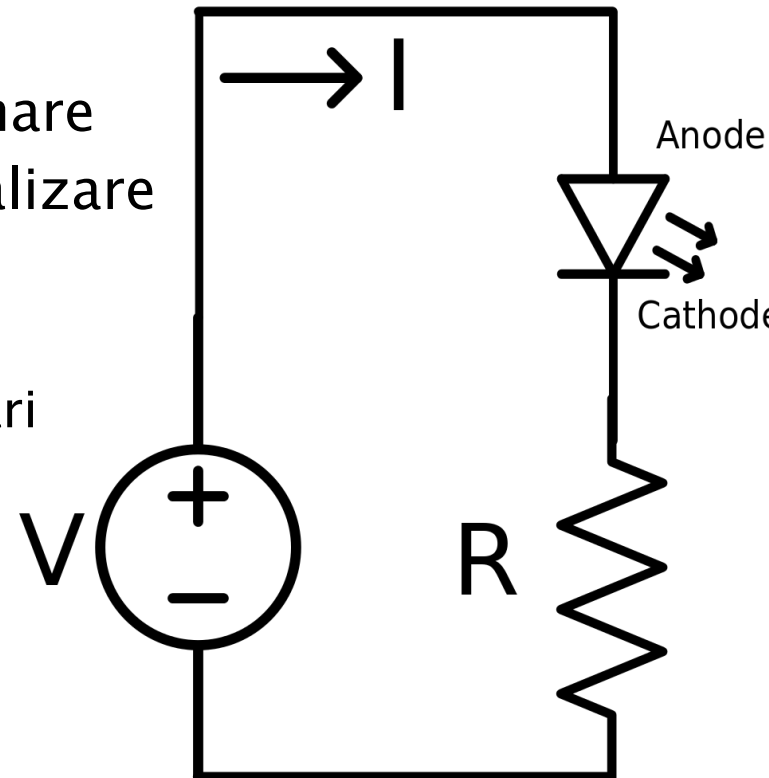

Control static LED



Ultra Bright LED Lamps Round Types

Package	Part No.	Chip			Absolute Maximum Ratings				Electro-optical Data(At 20mA)			Viewing Angle 2θ 1/2 (deg)	Drawing No.
		Material Emitted Color	Peak Wave Length p(nm)	Dominant Wave Length λd(nm)	Δλ (nm)	Pd (mw)	If (mA)	Peak (mA)	Vf (V)	Iv (mcd)	Typ.		
T-1 Standard 1.0" Lead 3φ Water Clear	BL-BF43V1	GaAlAs/ DDH Super Red	660	643 ± 5	20	80	30	150	2.0	2.6	700	25	L-001
	BL-BG33V1	InGaAlP/ Yellow Green	573	571 ± 5	15	100	30	150	2.2	2.6	700	25	
	BL-BG43V1	InGaN/SiC/ Bluish Green	505	505 ± 5	30	120	30	150	3.5	4.0	3500	24	
	BL-BG63V1	InGaN/SiC/ Green	525	525 ± 5	35	120	30	150	3.5	4.0	4000	24	
	BL-BJ23V1	InGaAlP/ Super Orange	620	615 ± 5	17	100	30	150	2.2	2.6	1700	25	
	BL-BJ33V1	InGaAlP/ Super Orange	630	625 ± 5	17	100	30	150	2.2	2.6	1100	25	
	BL-BJ63V1	InGaAlP/ Super Orange	610	605 ± 5	17	100	30	150	2.2	2.6	1500	25	
	BL-BJ73V1	InGaAlP/ Super Orange	630	625 ± 5	17	100	30	150	2.2	2.6	1500	25	
	BL-BJH3V1	InGaAlP/ Super Orange	630	625 ± 5	17	100	30	150	2.2	2.6	2500	25	
	BL-BJG3V1	InGaAlP/ Super Orange	630	625 ± 5	17	100	30	150	2.2	2.6	3000	25	
	BL-BK43V1	InGaAlP/ Super Yellow	590	587 ± 5	15	100	30	150	2.2	2.6	1600	25	
	BL-BK53V1	InGaAlP/ Super Yellow	595	594 ± 5	15	100	30	150	2.2	2.6	1500	25	
	BL-BK73V1	InGaAlP/ Super Yellow	595	594 ± 5	15	100	30	150	2.2	2.6	2000	25	
	BL-BK83V1	InGaAlP/ Super Yellow	590	587 ± 5	15	100	30	150	2.2	2.6	2000	25	
	BL-BKH3V1	InGaAlP/ Super Yellow	590	587 ± 5	15	100	30	150	2.2	2.6	2500	25	
	BL-BKG3V1	InGaAlP/ Super Yellow	590	587 ± 5	15	100	30	150	2.2	2.6	3000	25	
BL-BF43V4V	GaAlAs/ DDH Super Red	660	643 ± 5	20	80	30	150	2.0	2.6	1200	15		
BL-BG33V4V	InGaAlP/ Yellow Green	573	571 ± 5	15	100	30	150	2.2	2.6	1100	15		
BL-BG43V4V	InGaN/SiC/ Bluish Green	505	505 ± 5	30	120	30	150	3.5	4.0	6000	24		
BL-BG63V4V	InGaN/SiC/ Green	525	525 ± 5	35	120	30	150	3.5	4.0	5600	24		

3.5	4.0	3500
3.5	4.0	4000
2.2	2.6	1700
2.2	2.6	1100

◆ Electro-Optical Characteristics

Item	Symbol	Condition	Minimum	Typical	Maximum	Unit
Forward Voltage	V _F	I _F = 240 mA		19.0		V
Brightness	I _v	I _F = 240 mA		13		cd
Total Radiated Power	P _o	I _F = 240 mA		60		mW

Control dinamic LED

- ▶ Variatii mici ale tensiunii (mai ales in jurul tensiunii de deschidere) pot duce la varii mari ale curentului
- ▶ Se prefera de multe ori controlul in curent al LED-ului

Control dinamic LED, Lab 1

- ▶ Control in tensiune
 - Schema electrică a emițătorului în impuls

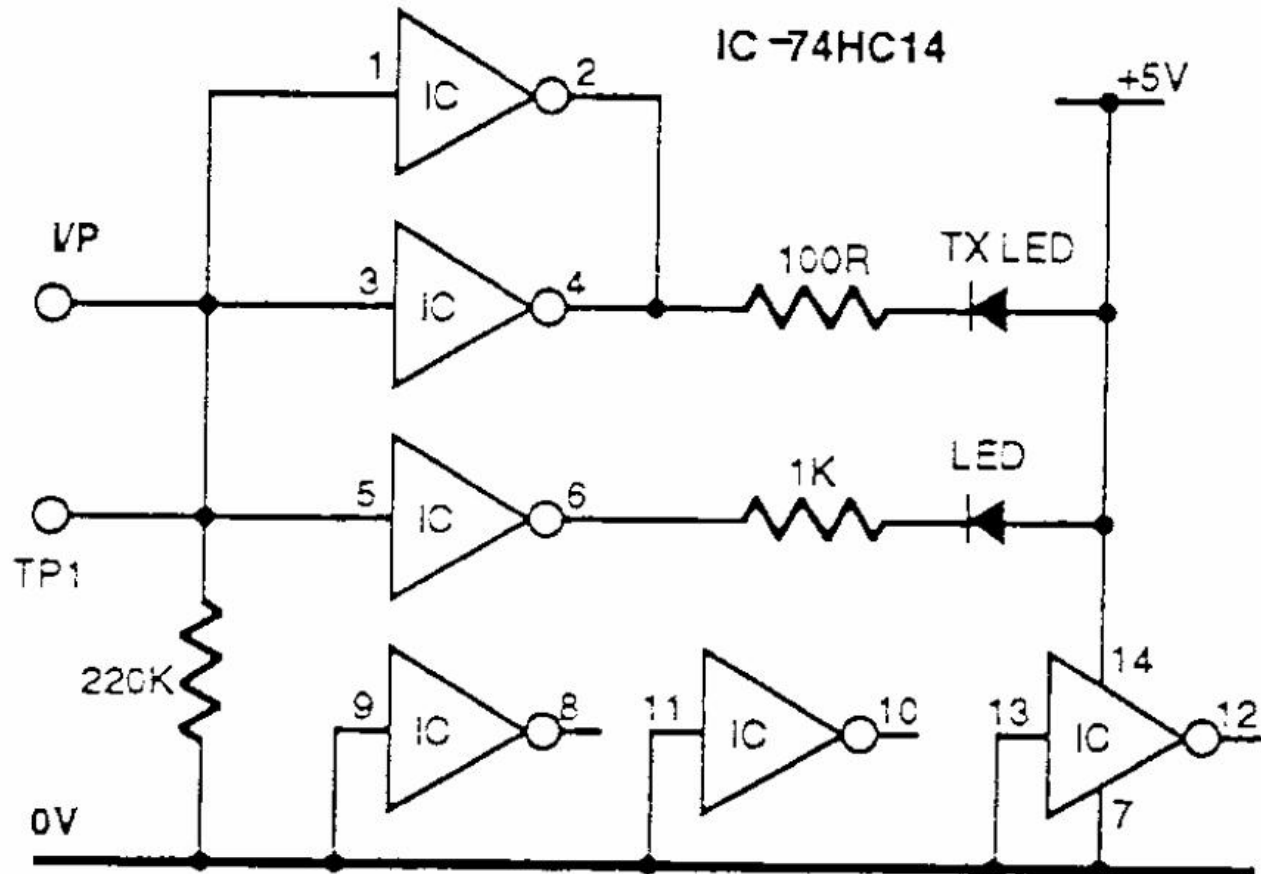

Control dinamic LED, Lab 1

- ▶ Control in curent
 - Schema electrică a emițătorului optic analogic

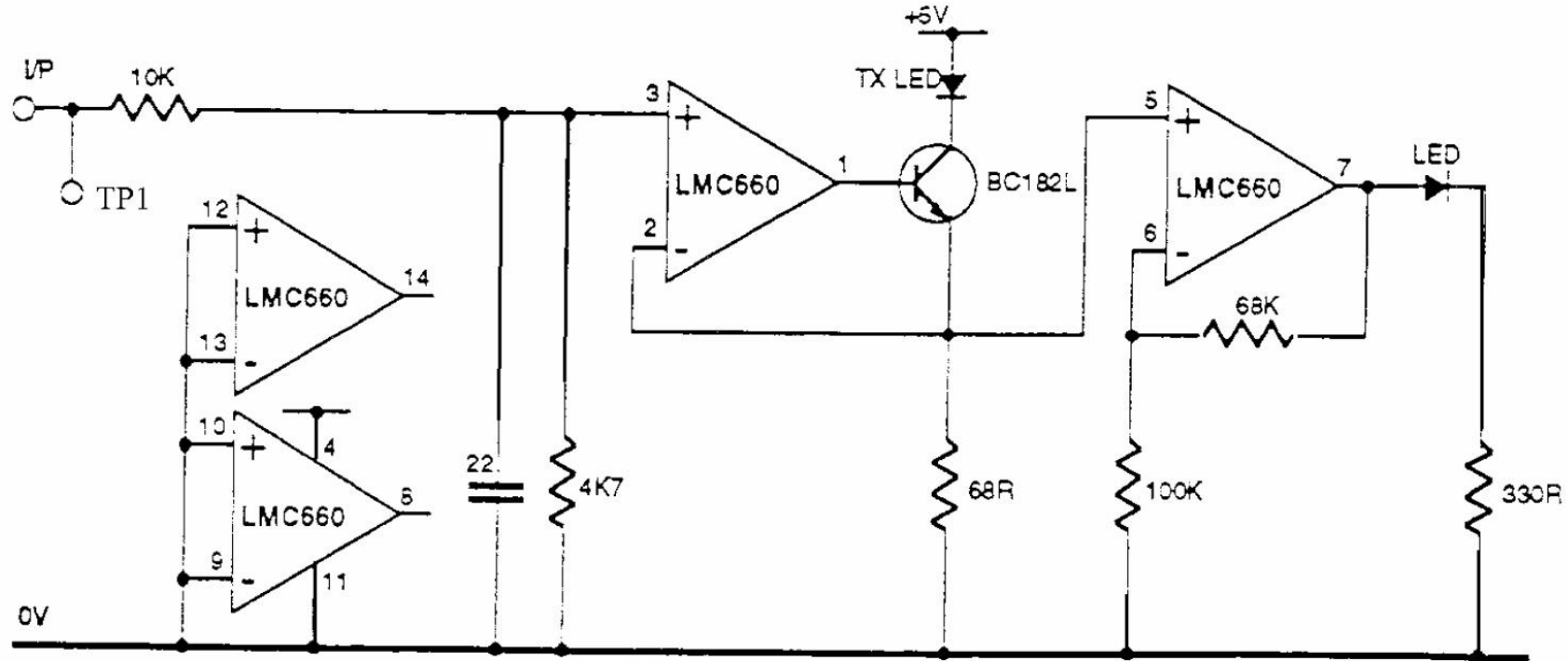

Dioda Laser

Capitolul 8

Caracteristici dioda laser

▶ Avantaje

- Putere optica ridicata (50mW functionare continua, 4W functionare in impulsuri)
- Precizie ridicata a controlului (impulsuri cu latimea de ordinul fs – femptosecunde) – viteza mare de lucru
- Spectru ingust, teoretic LASER ofera o singura linie spectrala
- Lumina coerenta si directiva (~80% poate fi cuplata in fibra)

▶ Dezavantaje

- Cost (dispozitiv si circuit de comanda: controlul puterii si al temperaturii)
- Durata de viata
- Sensitivitate crescuta cu temperatura
- Modulatie analogica dificila (de obicei cu dispozitive externe)
- Lungime de unda fixa

Dioda LASER – Principiu de operare

- ▶ LASER = Light Amplification by the Stimulated Emission of Radiation = Amplificarea Luminiilor prin Emisie Stimulată
- ▶ Un foton incident poate cauza prin absorbție tranziția unui electron pe un nivel energetic superior

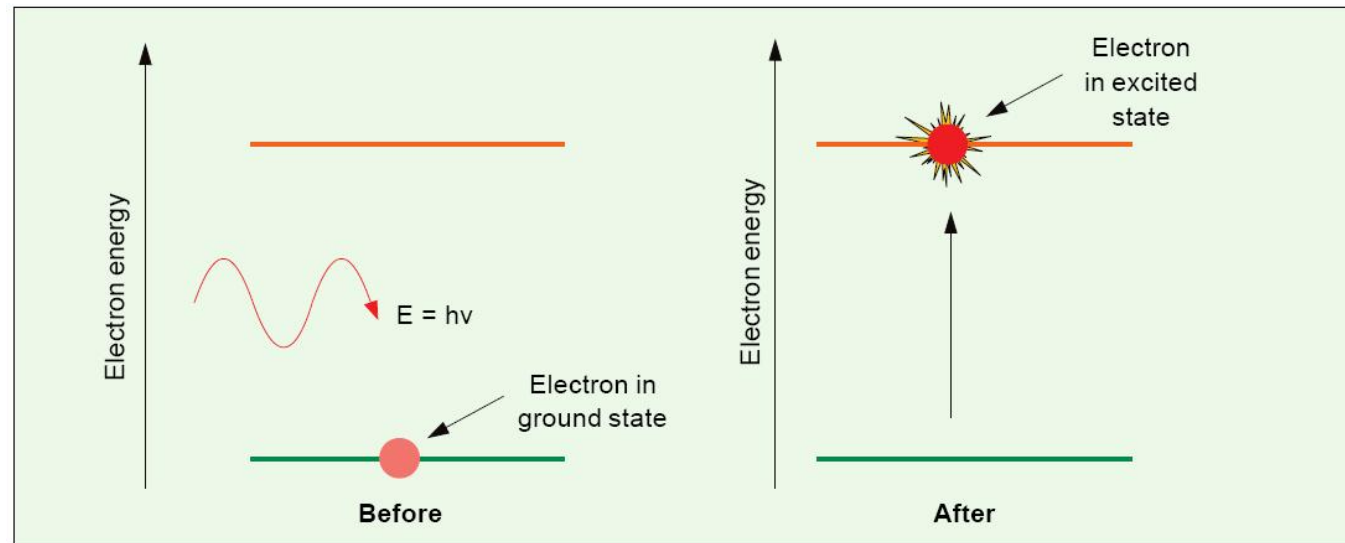

Dioda LASER – Principiu de operare

- ▶ Emisia spontana – electronul trece in starea energetica de echilibru emitand un foton
- ▶ Trecerea se realizeaza prin recombinarea unei perechi electron–gol
- ▶ Directia si faza radiatiei emise sunt aleatoare

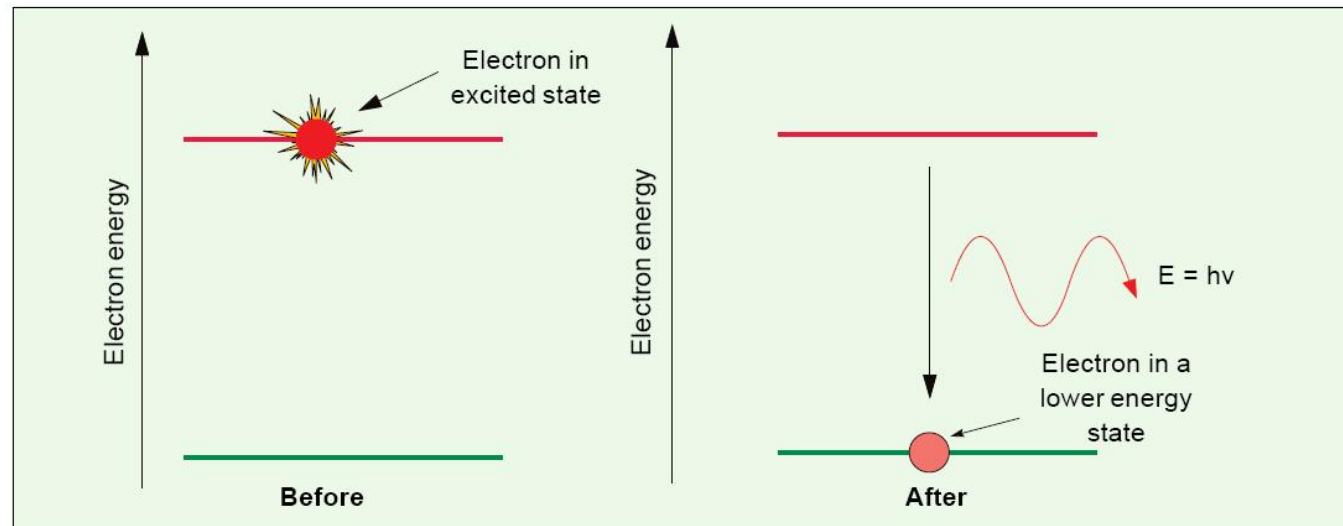

Dioda LASER – Principiu de operare

- ▶ Emisia stimulata – un foton incident cu energie corespunzatoare poate stimula emisia unui al doilea foton **fara a fi absorbit**
- ▶ Noul foton are aceeasi directie si faza cu fotonul incident, Lumina rezultata e coerenta

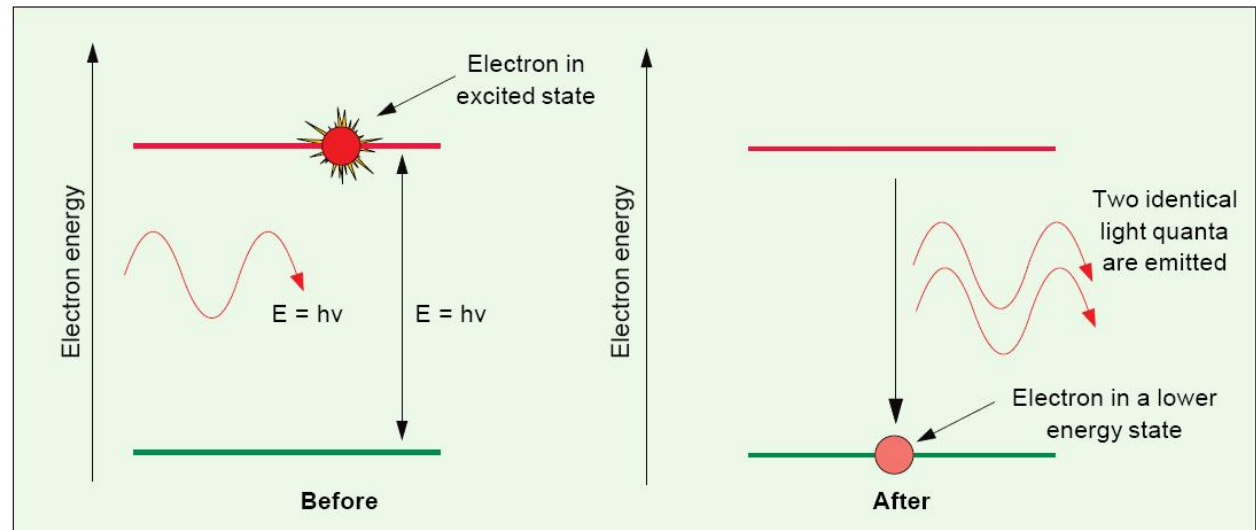

Detalii constructive

- ▶ Recombinarea unei perechi electron–gol necesita conservarea impulsului
- ▶ In Si si Ge aceasta conditie presupune aparitia unui foton intermediar (tranzitie indirecta) a carui energie se transforma in caldura
- ▶ Se utilizeaza aliaje de Ga Al As sau In Ga As P
- ▶ Spatierea atomilor in diferitele straturi trebuie sa fie egala (toleranta 0.1%) pentru a nu se introduce defecte mecanice la jonctiune
 - limitare a aliajelor utilizabile
 - aparitia defectelor
 - creste ineficienta (recombinari neradiative)
 - scade durata de viata a dispozitivului

Lățimea benzii interzise/lungime de undă pentru materialele uzuale

Material	Formula	Wavelength Range λ (μm)	Bandgap Energy W_g (eV)
Indium Phosphide	InP	0.92	1.35
Indium Arsenide	InAs	3.6	0.34
Gallium Phosphide	GaP	0.55	2.24
Gallium Arsenide	GaAs	0.87	1.42
Aluminium Arsenide	AlAs	0.59	2.09
Gallium Indium Phosphide	GaInP	0.64-0.68	1.82-1.94
Aluminium Gallium Arsenide	AlGaAs	0.8-0.9	1.4-1.55
Indium Gallium Arsenide	InGaAs	1.0-1.3	0.95-1.24
Indium Gallium Arsenide Phosphide	InGaAsP	0.9-1.7	0.73-1.35

$$E_g = h\nu; \quad \lambda = \frac{hc}{E_g}; \quad \lambda[\mu\text{m}] = \frac{1.240}{E_g[\text{eV}]}$$

- ▶ h constanta lui Plank
 $6.6261 \cdot 10^{-34} \text{ W s}^2$
- ▶ c viteza luminii **in vid**
 $2.998 \cdot 10^8 \text{ m/s}$
- ▶ e sarcina electronului
 $1.6 \cdot 10^{-19} \text{ C}$
- ▶ benzi energetice: λ_0 , $\Delta\lambda$

Dependența benzii interzise de constanta rețelei

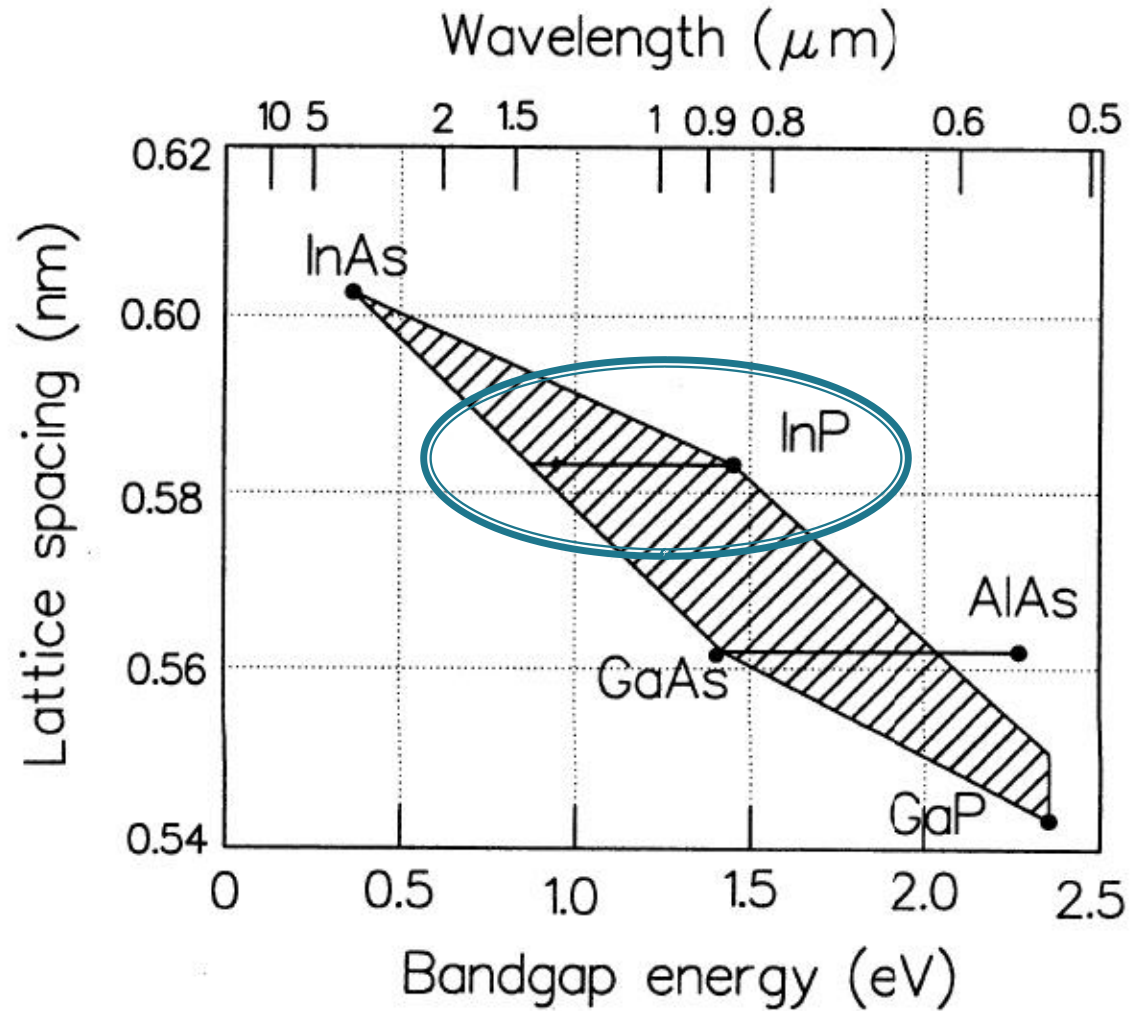
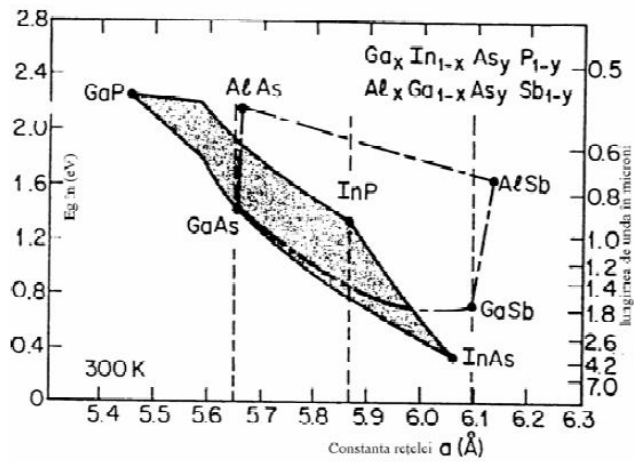

Materiale

- ▶ Lungimi de unda mici (spectru vizibil – 1000nm)
 - GaP (665nm), $\text{GaAs}_y\text{P}_{1-y}$
 - GaAs (900nm), $\text{Ga}_{1-x}\text{Al}_x\text{As}$ (AlAs – 550nm)
- ▶ Lungimi de unda mari (1000÷1700nm)
 - $\text{In}_x\text{Ga}_{1-x}\text{As}_y\text{P}_{1-y}$
 - x,y concentratii relative in aliaj a materialelor corespunzatoare
 - x,y alese din considerente privind
 - lungimea de unda
 - spatierea atomilor

Materiale

- ▶ Lungimi de unda mici
 - $\text{Ga}_{1-x}\text{Al}_x\text{As}$
 - substrat GaAs
 - limitare pentru tranzitie directa, $x < 0.45$
 - E_g (in eV)

$$E_g = 1.424 + 1.247 \cdot x, \quad x < 0.45$$

$$E_g = 1.9 + 0.125 \cdot x + 0.143 \cdot x^2, \quad x > 0.45$$

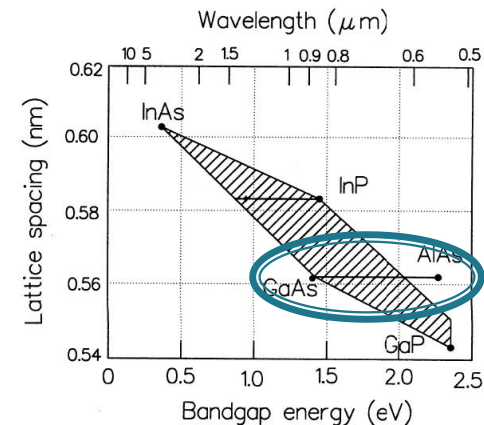
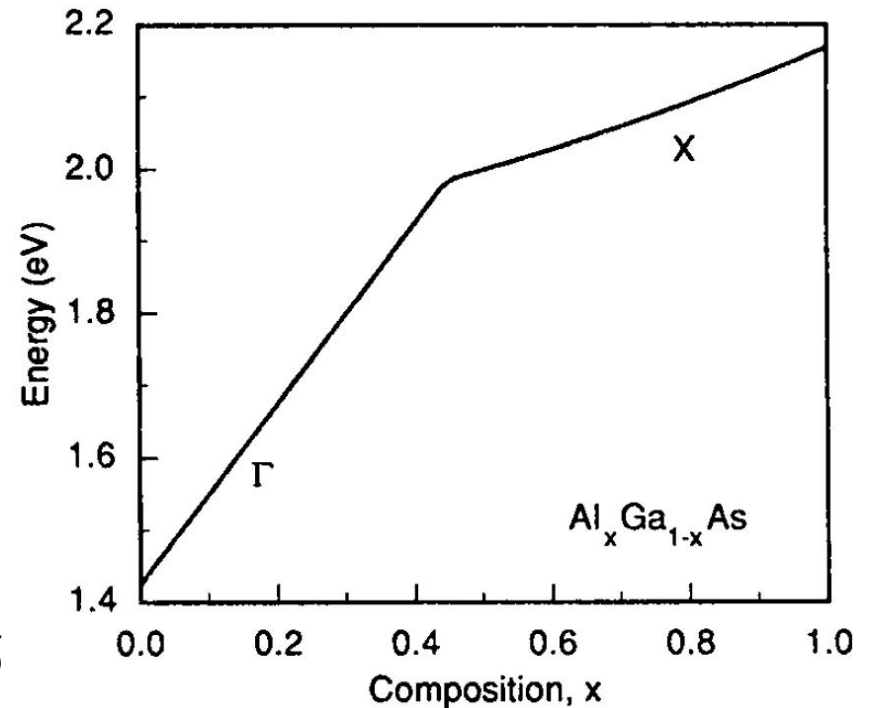

Materiale

- ▶ Lungimi de unda mari
 - $\text{In}_x\text{Ga}_{1-x}\text{As}_y\text{P}_{1-y}$
 - Tipic substratul este InP
 - Spatierea atomilor (lattice spacing) corespunzatoare InP

$$x = \frac{0.4526 \cdot y}{1 - 0.031 \cdot y}$$

- E_g (in eV)

$$E_g = 1.35 - 0.72 \cdot y + 0.12 \cdot y^2$$

- Exemplu: 1300nm se obtine cu $y=0.611$ si $x=0.282$,

- $\text{In}_{0.282}\text{Ga}_{0.718}\text{As}_{0.611}\text{P}_{0.389}$

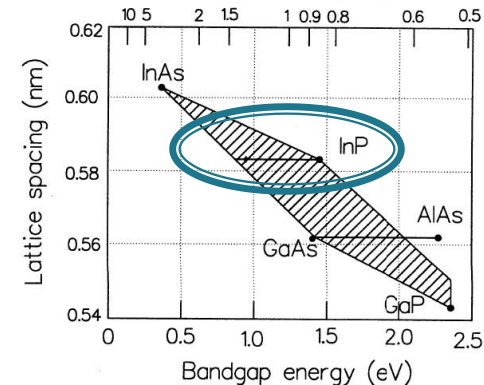
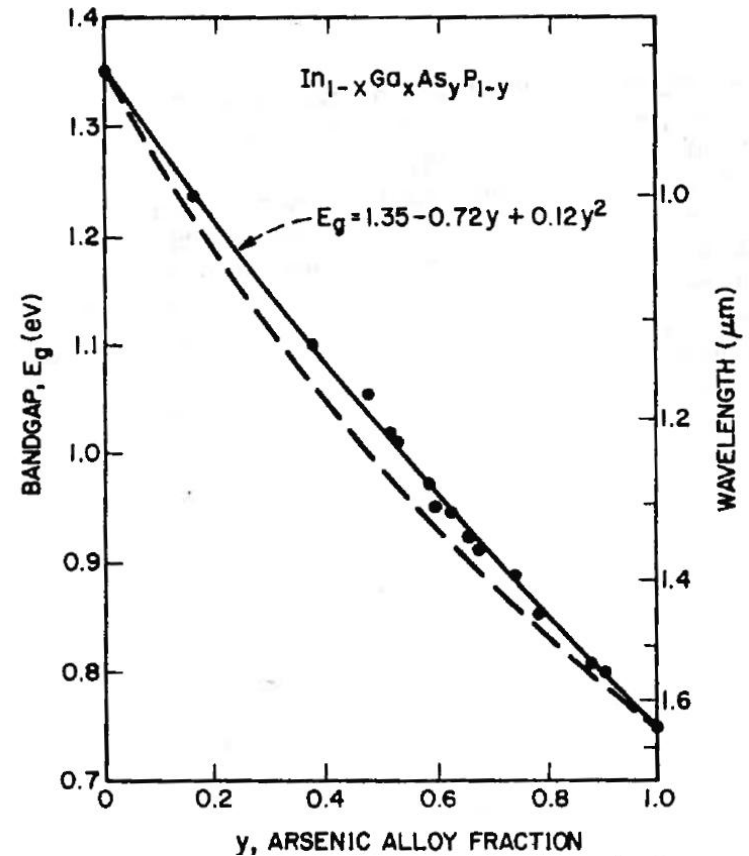

Principii LASER

- ▶ Inversiune de populatie
 - necesara deoarece electronii au capabilitatea de a absorbi energie **la aceeasi frecventa** la care are loc emisia stimulata
 - se defineste probabilistic: probabilitatea de emisie stimulata sa fie mai mare decat probabilitatea de absorbtie

$$n_c \cdot p_e > n_v \cdot p_a$$

- ▶ Materialele capabile sa genereze inversiune de populatie au starea excitata metastabila

Materialie cu 4 nivele energetice

- ▶ La un material cu 4 nivele energetice tranzitia radianta a electronului (3) se termina intr-o stare instabila, starea de echilibru obtinandu-se prin emisia unui fonon
- ▶ Inversiunea de populatie se obtine mult mai usor datorita electronilor din starea intermediara

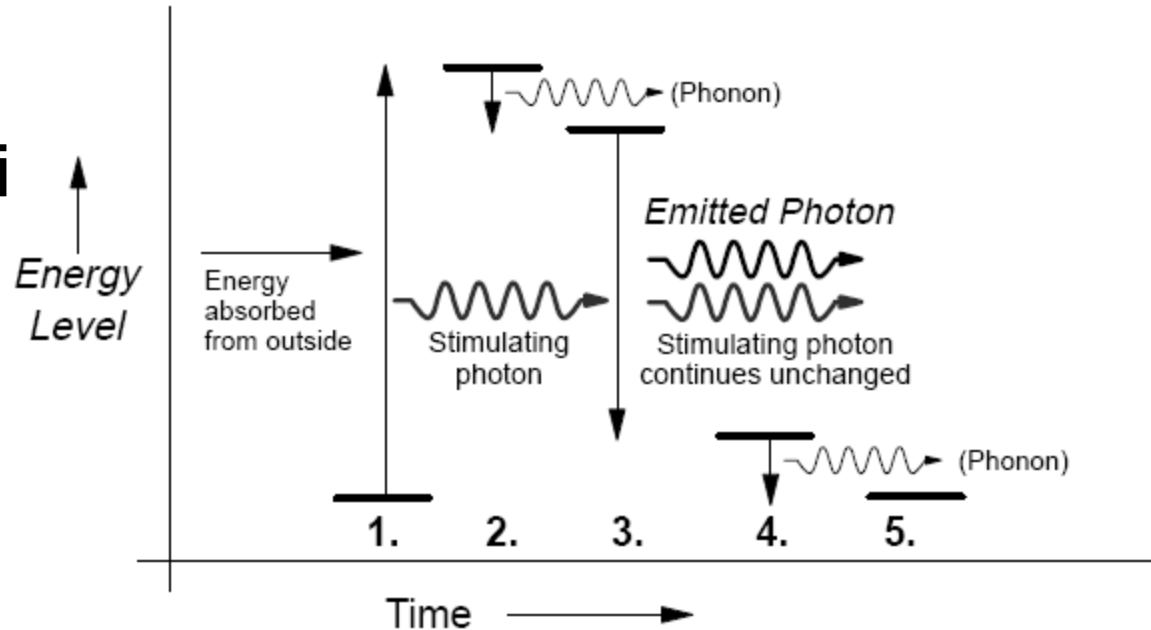

Dioda LASER – Principiu de realizare

- ▶ Pentru ca emisia stimulata sa apara, fotonii emisi trebuie sa ramana in contact cu materialul o perioada mai mare de timp – 2 oglinzi necesare
- ▶ Pentru a permite extragerea radiatiei e necesar ca una din oglinzi sa fie partial reflectanta

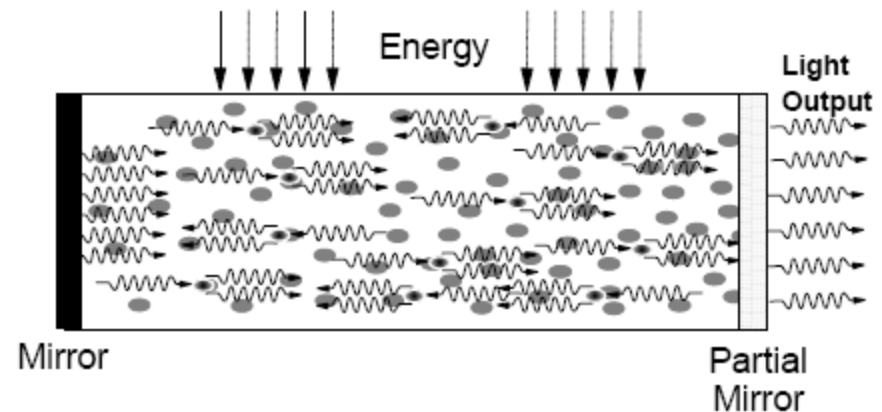

Dioda LASER – Principiu de realizare

- ▶ Pentru diodele laser utilizate in comunicatii reflectivitatea oglinzilor nu trebuie sa fie foarte mare
- ▶ Interfata semiconductor aer ofera un coeficient de reflexie de $\sim 6\%$ dar poate ajunge la 36% pentru lungimea de unda de operare (vezi lamela dielectrica)

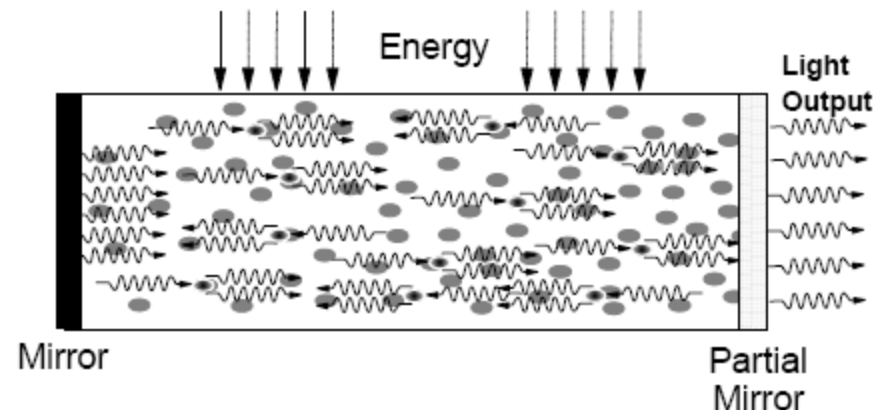
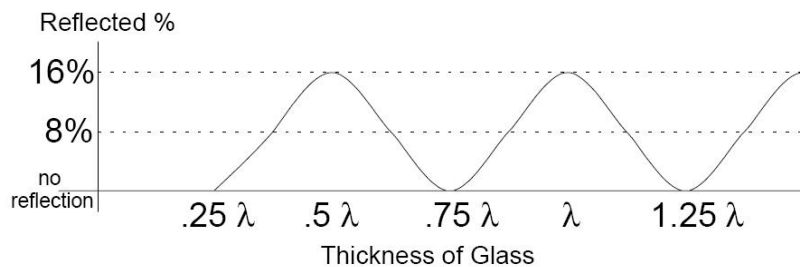

Dioda LASER – Principiu de realizare

- ▶ Pentru a realiza
 - coerența radiației
 - interferența constructivă între radiațiile incidente și reflectate de oglinzi,
- ▶ distanța între oglinzi trebuie să fie un multiplu al jumătății din lungimea de undă

$$L = k \cdot \frac{1}{2} \cdot \frac{\lambda_0}{n} \qquad L = k \cdot \frac{c_0}{2 \cdot n \cdot f} \qquad f = k \cdot \frac{c_0}{2 \cdot n \cdot L}$$

- ▶ Pentru eficientizarea pomparii de energie din exterior $L = 100 \div 200 \mu\text{m}$, $k \cong 400$

Dioda LASER Fabry Perot

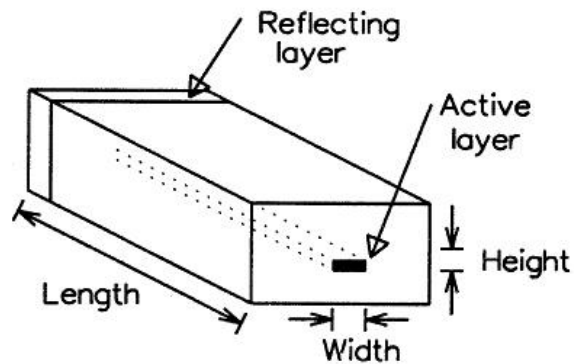
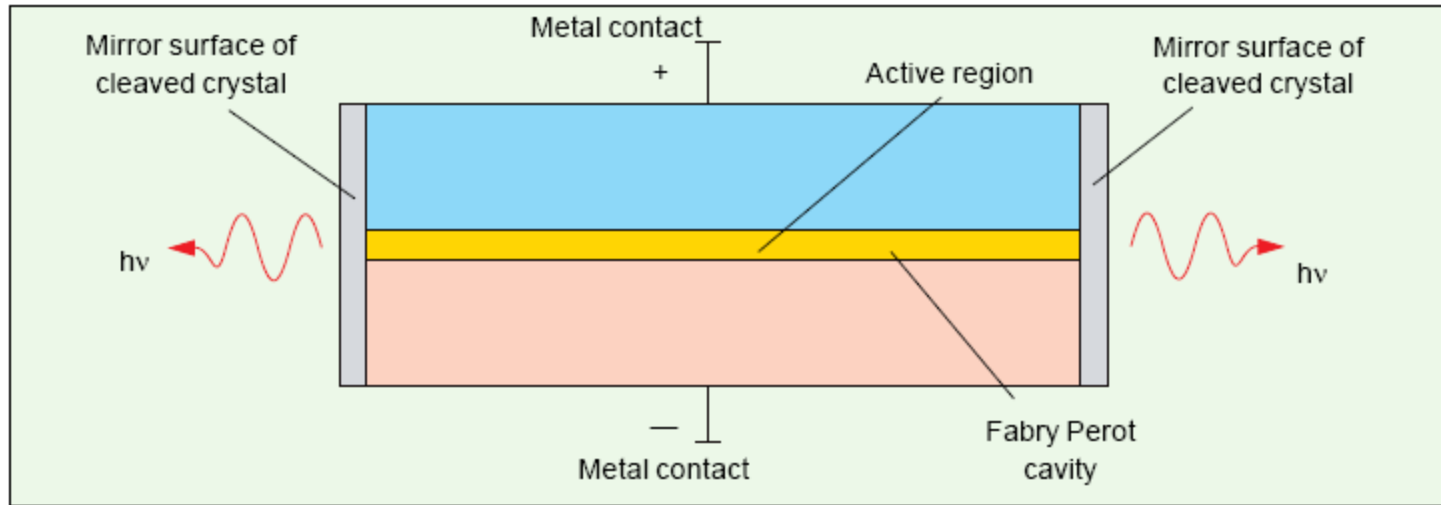

Height: 0.1 – 0.2 μm
Length: 250 – 500 μm
Width: 5 – 15 μm
Sides: rough-cut
Front: cleaved
Back: 100% reflector

Definirea directiilor in dioda LASER

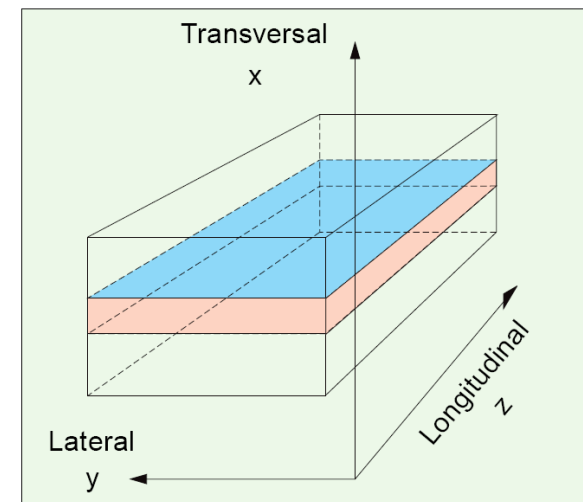

Spectrul diodei LASER

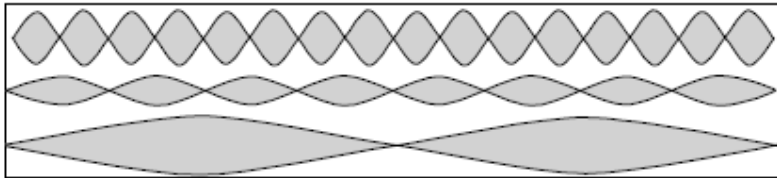

Longitudinal Modes

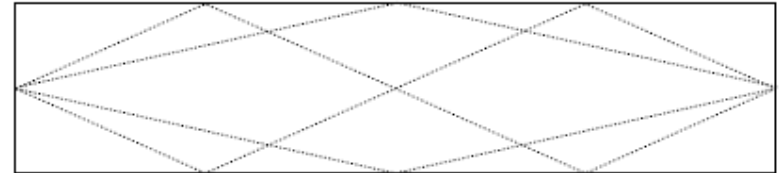

Lateral Modes

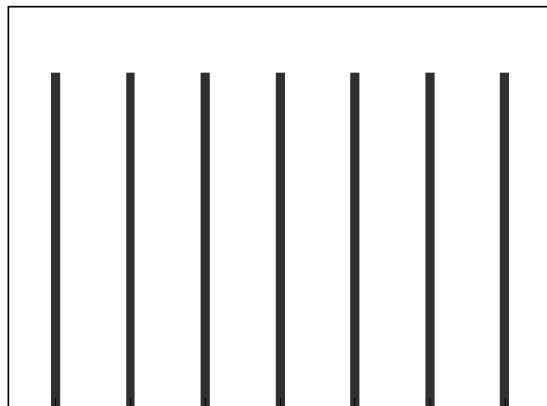

1.490 1.494 1.497 1.5 1.503 1.507 1.510
Wavelength (nm)

$$f_k = k \cdot \frac{c_0}{2 \cdot n \cdot L} \quad \Delta f = \frac{c_0}{2 \cdot n \cdot L}$$

$$\Delta \lambda \cong \frac{\lambda_0^2}{2 \cdot n \cdot L}$$

Spectrul diodei LASER

- ▶ Castigul diodei laser (eficacitatea aparitiei emisiei stimulate) depinde
 - de caracteristicile energetice ale materialului din care e realizata dioda
 - de energia pompata din exterior (curentul prin dioda)

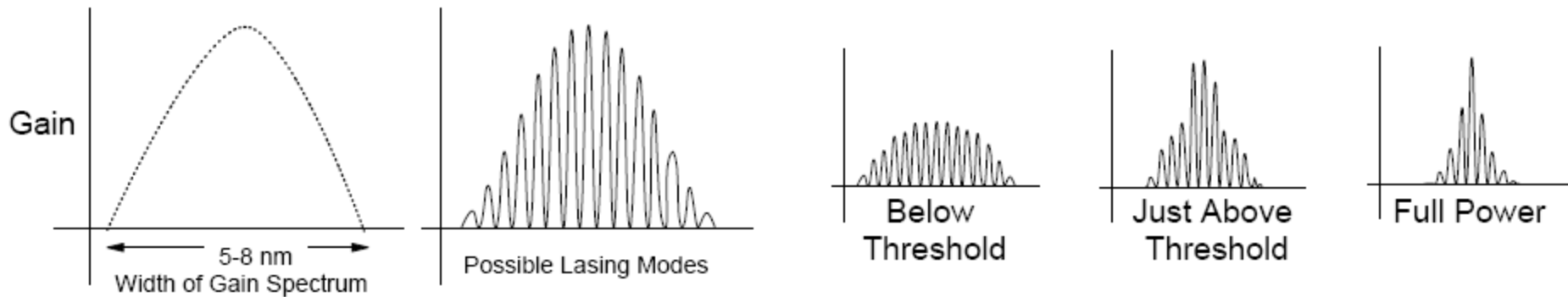

Distributed Feedback (DFB) Lasers

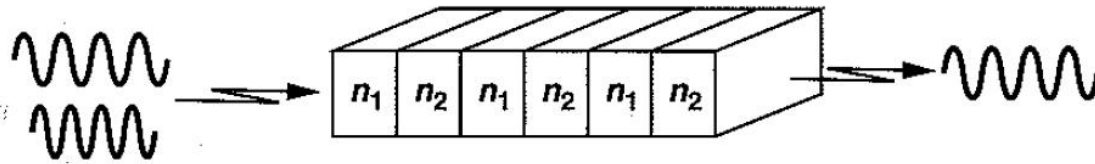
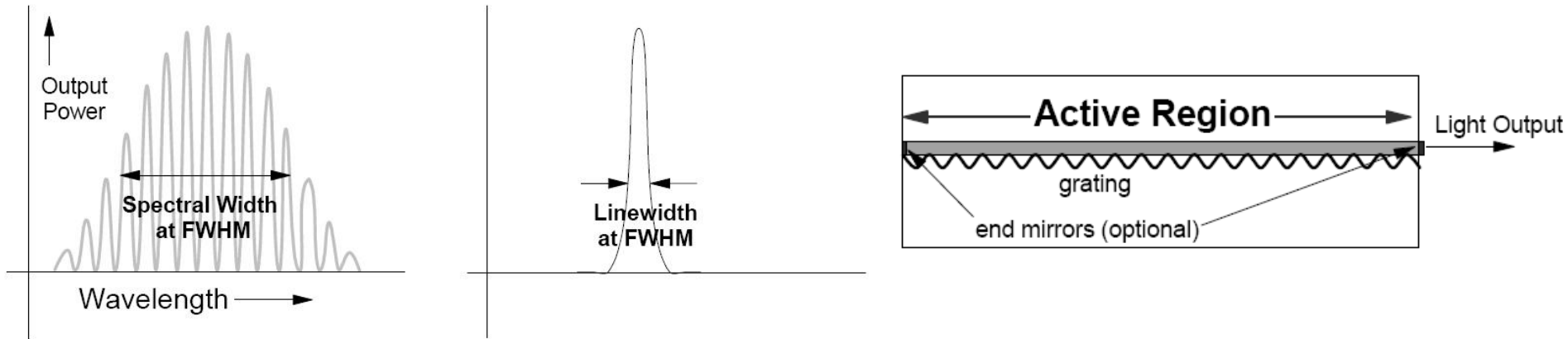

(a)

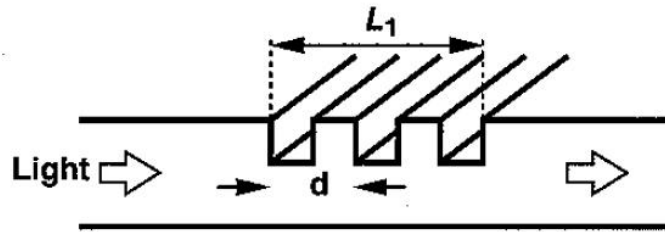

(b)

Filtre spatiale in
regiunea activa

Distributed Feedback (DFB) Lasers

- ▶ Pentru operarea in impulsuri, un salt de $\lambda/4$ ingusteaza suplimentar spectrul diodei laser

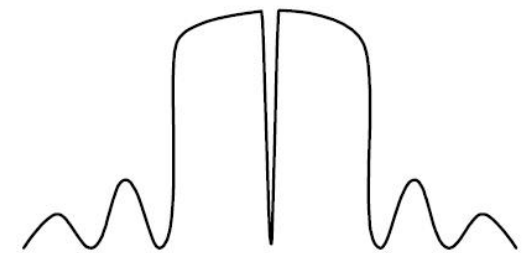
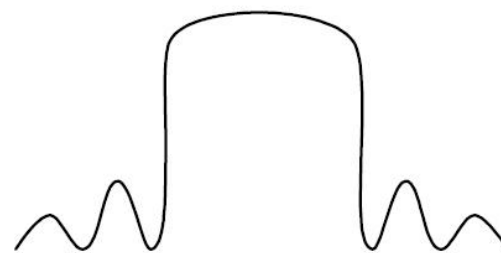
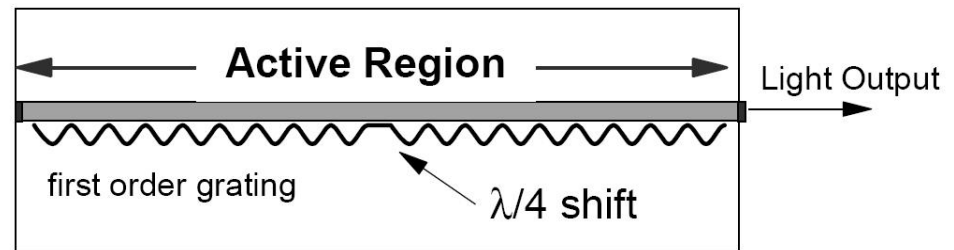
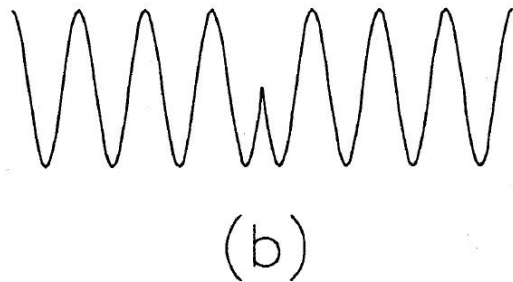
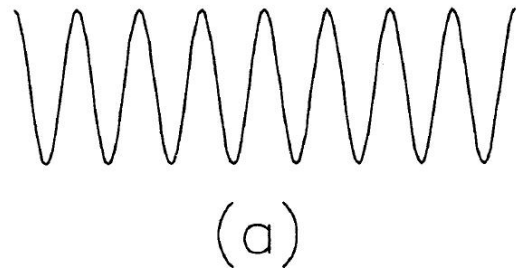

Distributed Bragg Reflector (DBR) Lasers

- ▶ Se utilizeaza suprafete reflective selective pentru filtrare optica

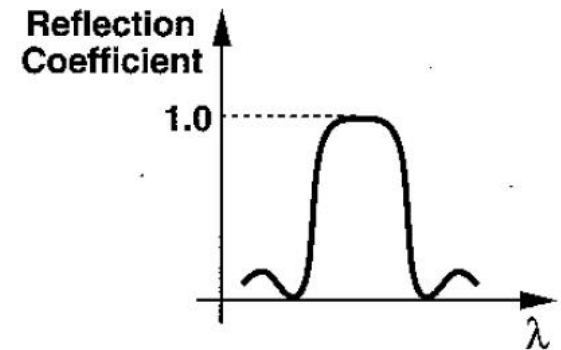
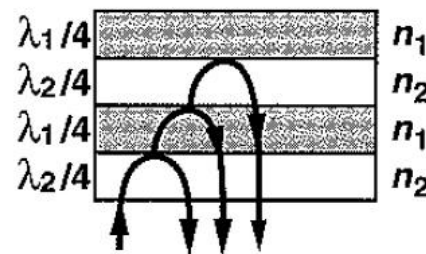
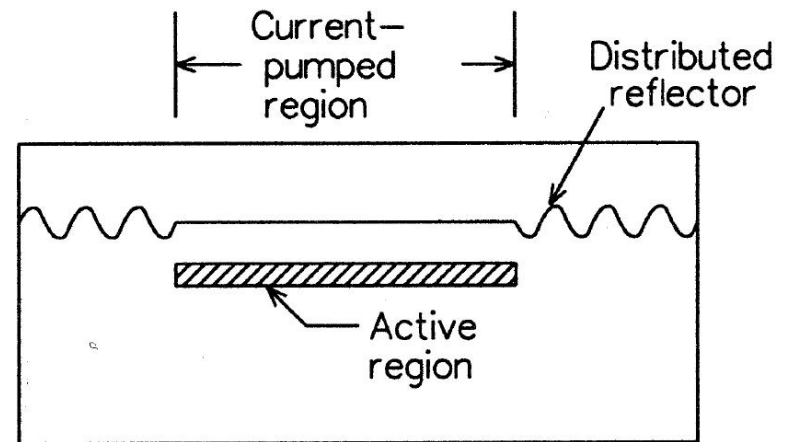

Caracteristici curent tensiune

- ▶ Amorsarea emisiei stimulate necesita pomparea unei anumite cantitati de energie – curent de prag

$$I > I_{th}$$

$$r = \frac{\Delta P_o}{\Delta I} \left[\frac{W}{A} \right]$$

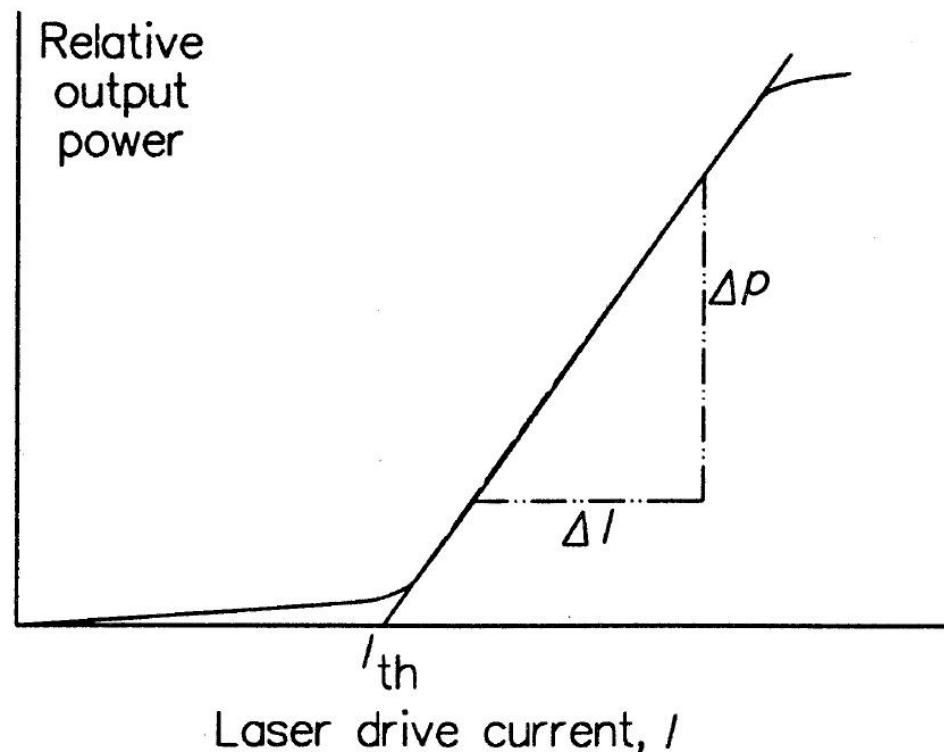

Temperatura si îmbatrânire

- ▶ Curentul de prag variaza cu temperatura si cu timpul
- ▶ Variatia tipica 1–2%/°C

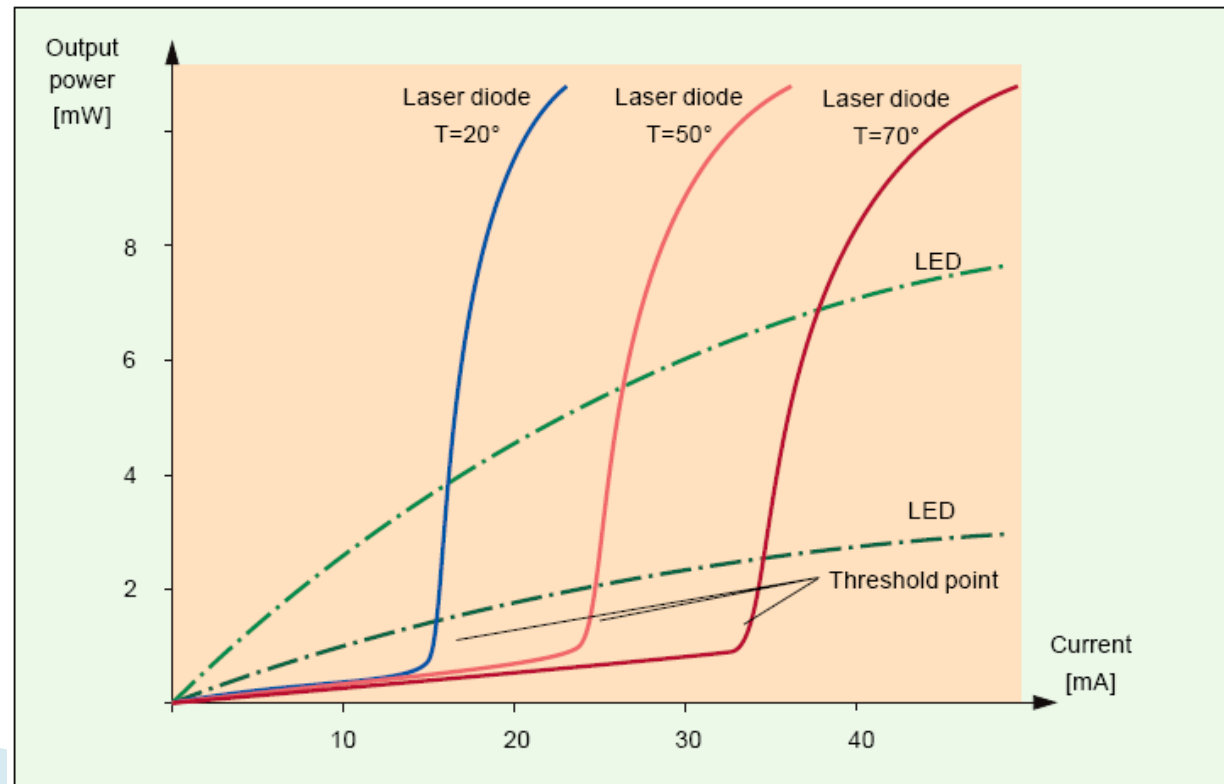

Dependenta de temperatura

- ▶ Dependenta de temperatura a curentului de prag este exponentiala

- ▶
$$I_{th} = I_0 \cdot e^{T/T_0}$$

- ▶ I_0 e o constanta determinata la temperatura de referinta

Material	Lungime de unda	T_0
InGaAsP	1300 nm	60÷70 K
InGaAsP	1500 nm	50÷70 K
GaAlAs	850 nm	110÷140 K

Monitorizarea radiației de spate

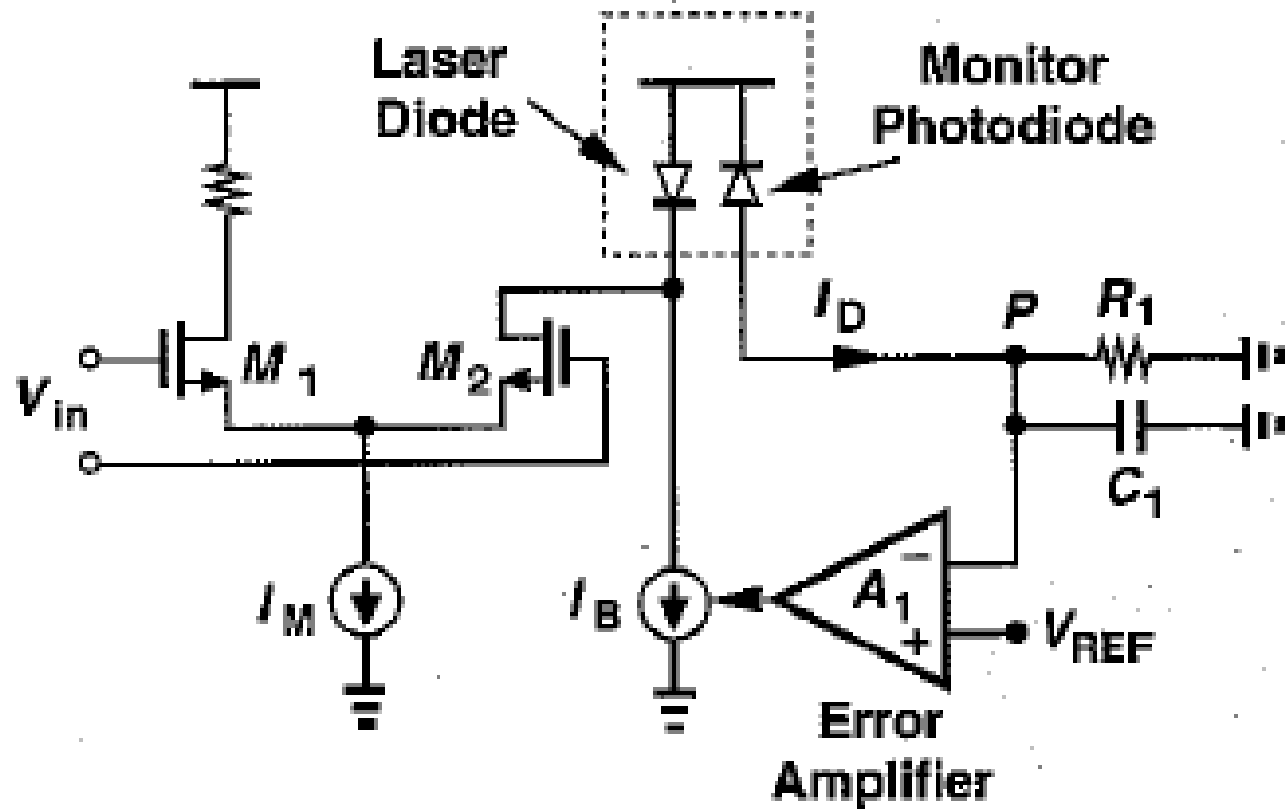

Direcționarea luminii în laser-ul Fabry Perot

(a) Unguided

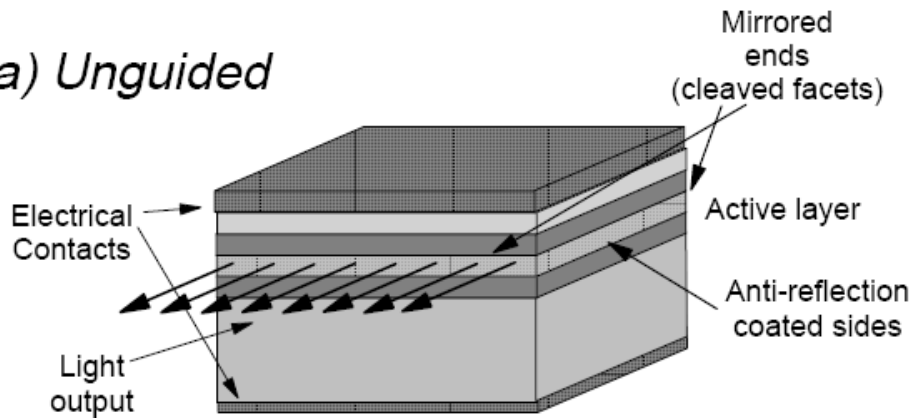

(b) Gain Guided

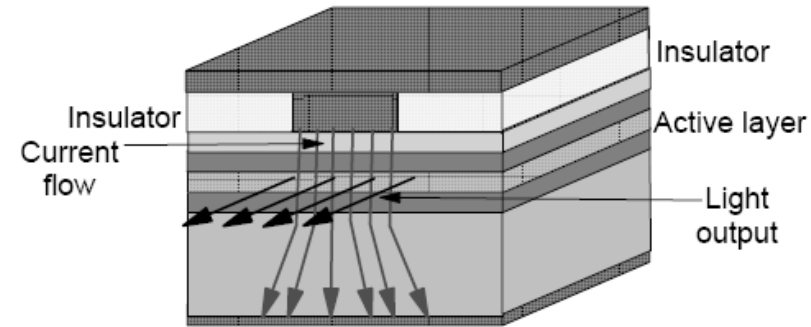

(c) Index Guided

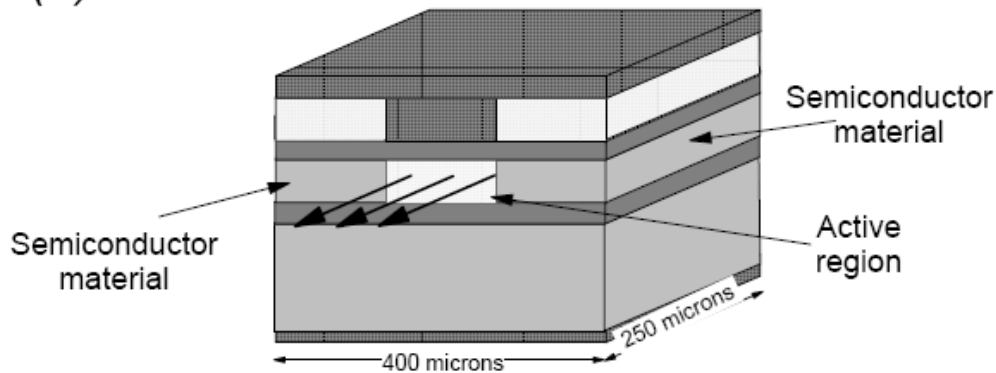

Efectul ghidarii

- ▶ Gain guided - 8 ÷ 20 linii spectrale (5 ÷ 8 nm)
- ▶ Index guided - 1 ÷ 5 linii spectrale (1 ÷ 3 nm)

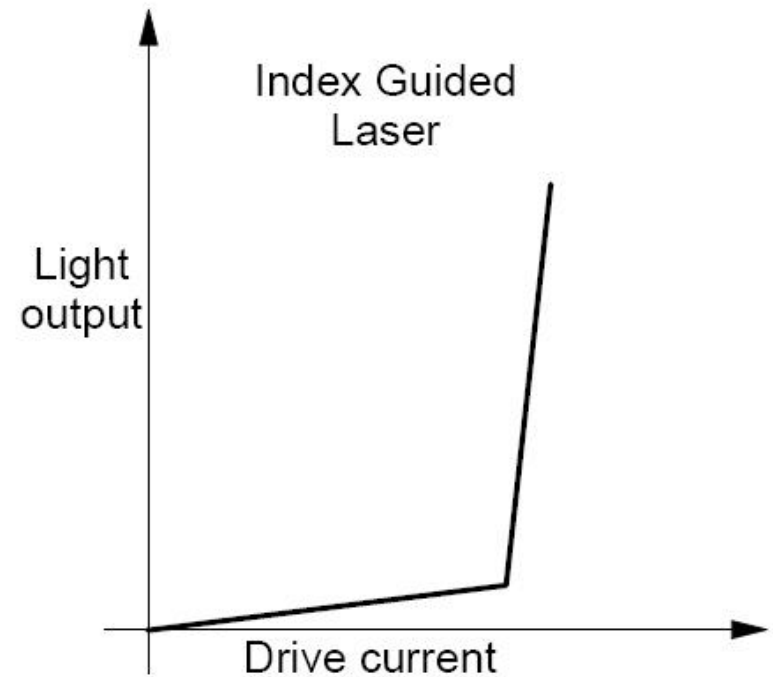
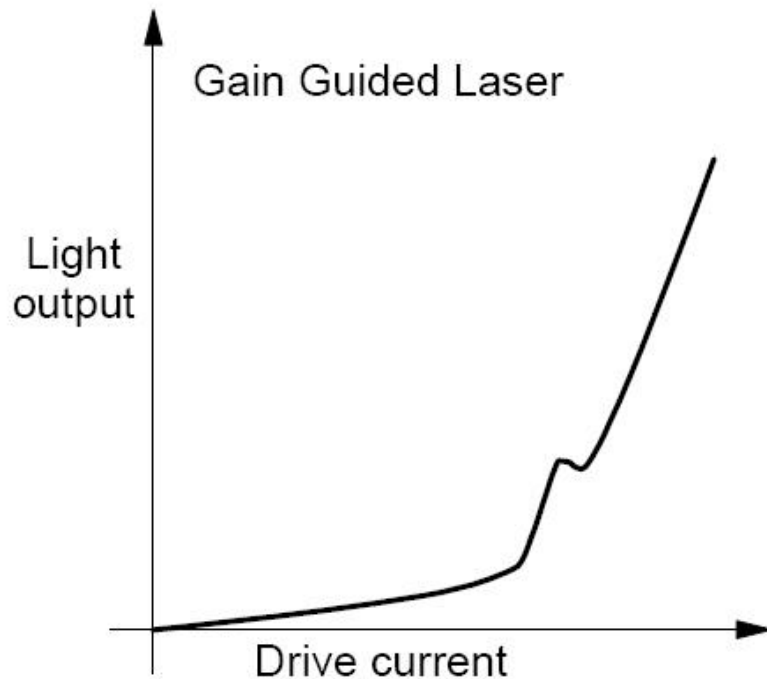

Cuplarea luminii în fibră

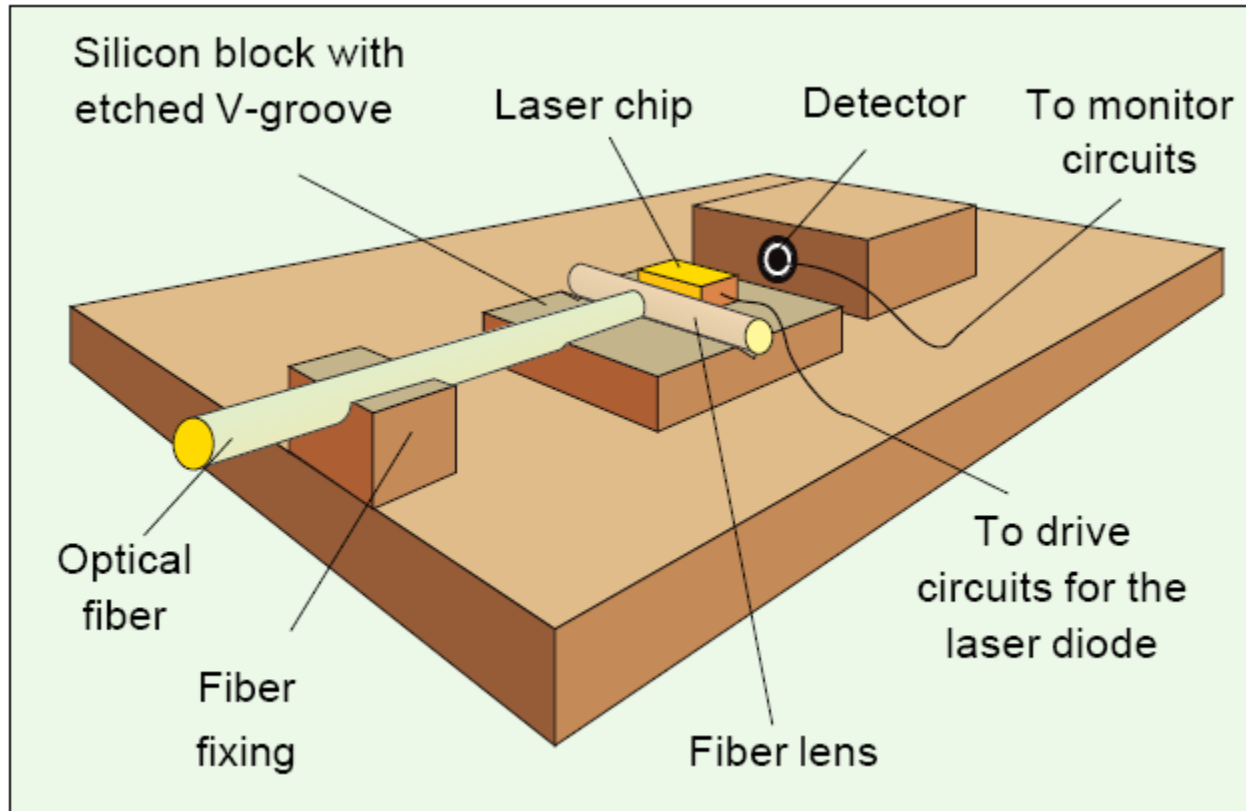

Directivitatea radiatiei exterioare

- ▶ Sursa Lambertiana

$$P(\theta) = P_0 \cdot \cos \theta$$

- Eficienta cuplarii in fibra

$$\eta = \frac{P_f}{P_s} = NA^2 \cdot \left(\frac{a}{r_s} \right)^2$$

$$\eta = \frac{P_f}{P_s} = NA^2 \cdot \left(\frac{a}{r_s} \right)^2 \cdot \left(\frac{g}{g+2} \right)$$

- ▶ Aproximatie Lambertiana pentru surse cu directivitate crescuta

$$P(\theta) = P_0 \cdot \cos^m \theta \quad \eta = \frac{P_f}{P_s} = \left(\frac{m+1}{2} \right) \cdot NA^2$$

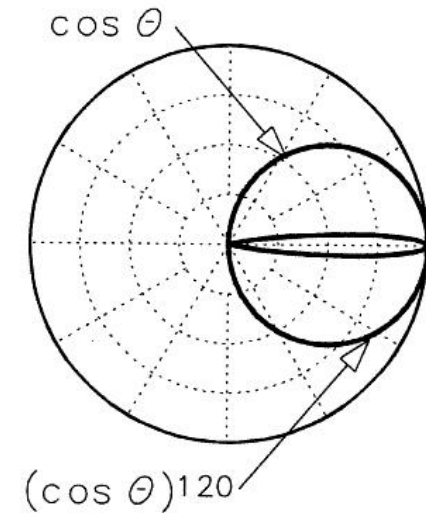

Turn-on delay

- ▶ La alimentarea cu curent a diodei laser emisia este initial spontana, devenind stimulata dupa amorsarea acesteia
- ▶ emisia spontana este un fenomen intrinsec aleator
- ▶ Intarzierea este variabila – jitter

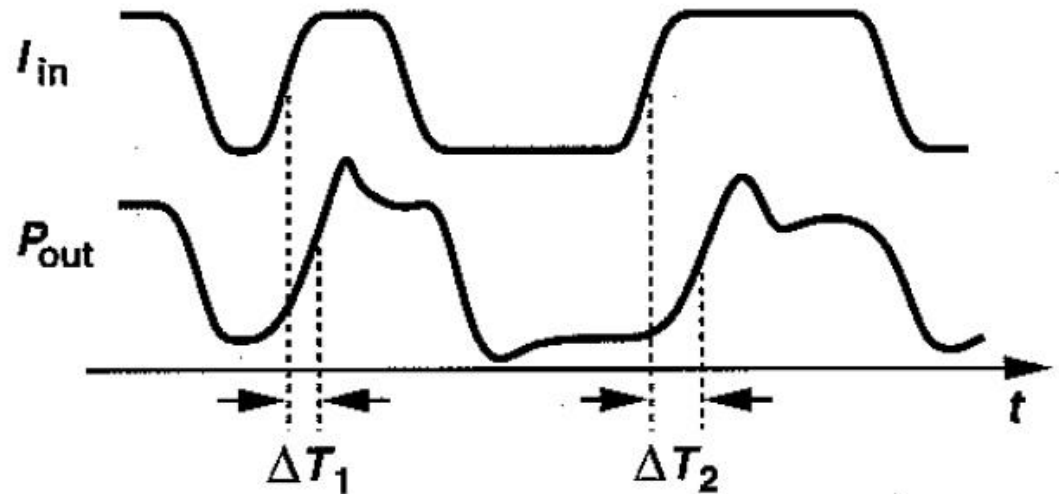

Chirping

- ▶ Frecventa de oscilatie depinde de indicele de refractie al materialului
- ▶ Indicele de refractie depinde de concentratia de purtatori
- ▶ Cand curentul este modulat in impuls apare o modulare a frecventei luminii cu efectul cresterii latimii spectrale a diodei (un ordin de magnitudine)

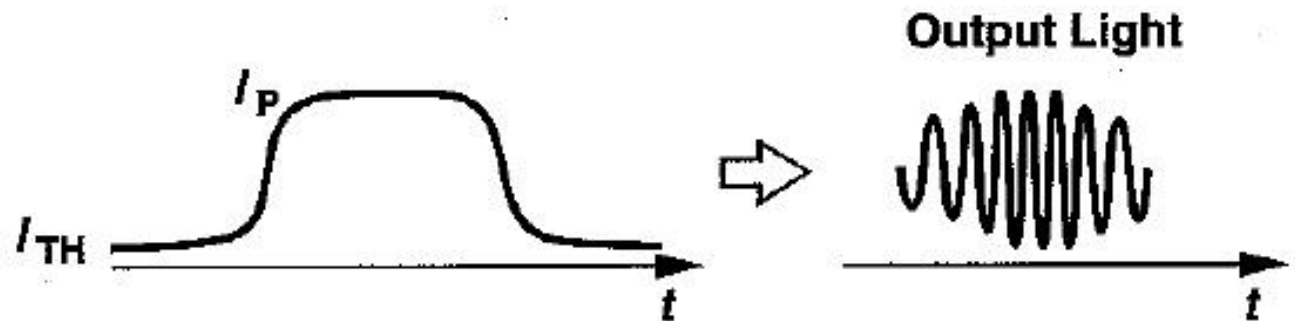

Raspunsul unei diode laser

- ▶ oscilatii de relaxare - x GHz

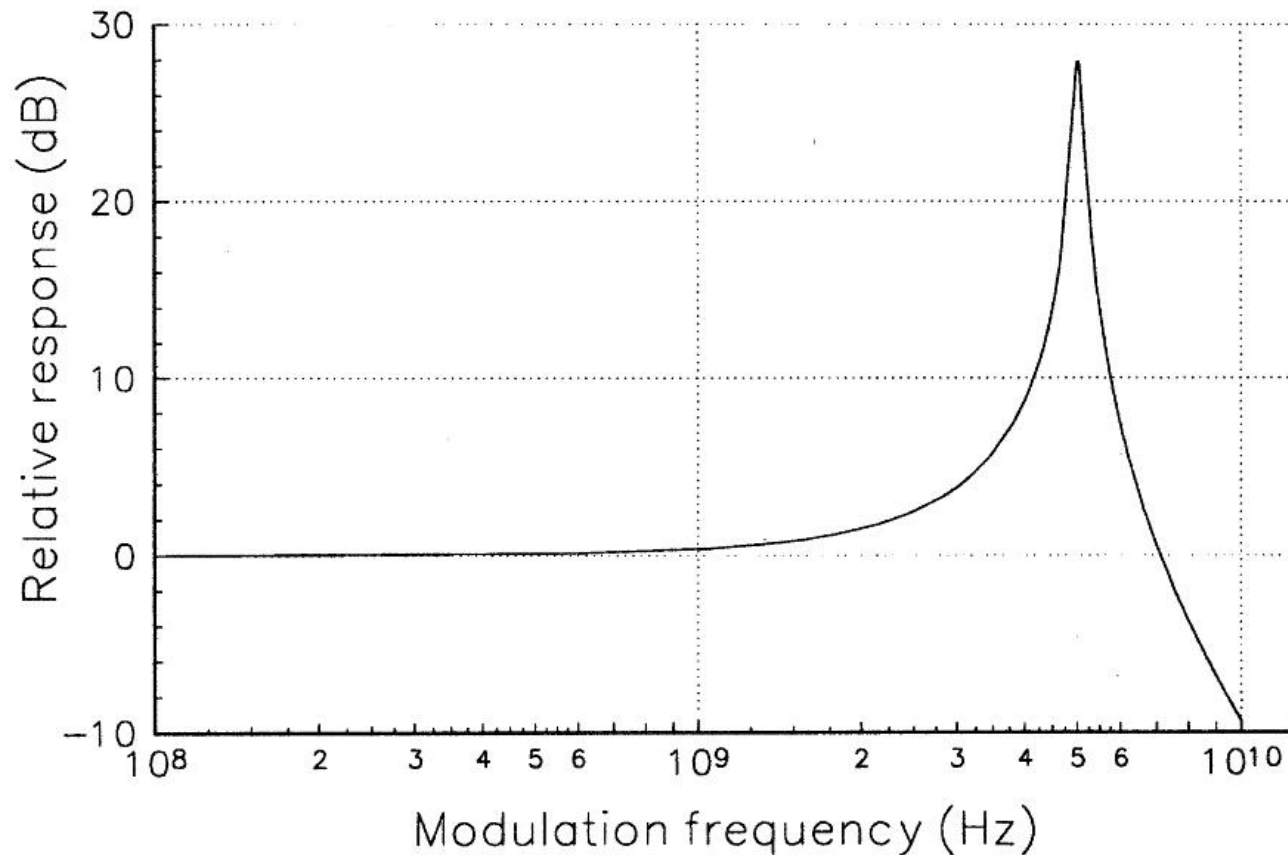

Oscilatii de relaxare

- ▶ Generate de schimburi de energie între electroni și fotoni
- ▶ Amorsarea emisie stimulate duce la descreșterea numărului de electroni în starea excitată, ceea ce duce la micșorarea emisie de fotoni
- ▶ Acumularea din nou a electronilor în starea excitată duce din nou la creșterea puterii

- ▶ $f_1 = 1 \div 4 \text{ GHz}$

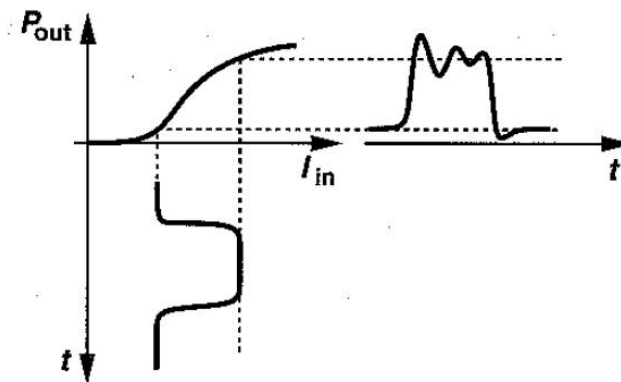

(a)

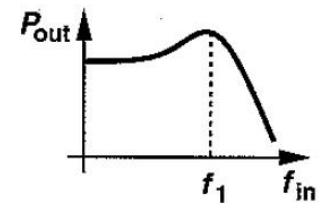

(b)

Oscilatii de relaxare

- ▶ Cresterea vitezei si minimizarea erorilor date de oscilatiile de relaxare si variatiile timpului de amorsare dioda este **partial** stinsa in timpul transmisiei unui nivel 0 logic

- ▶ Raport de stingere

$$ER = \frac{P_H}{\alpha \cdot P_H} = \frac{1}{\alpha}$$

- ▶ Raportul semnal zgomot scade cu $(1-\alpha)$

- ▶ Tipic $ER = 10 \div 15 \text{dB}$

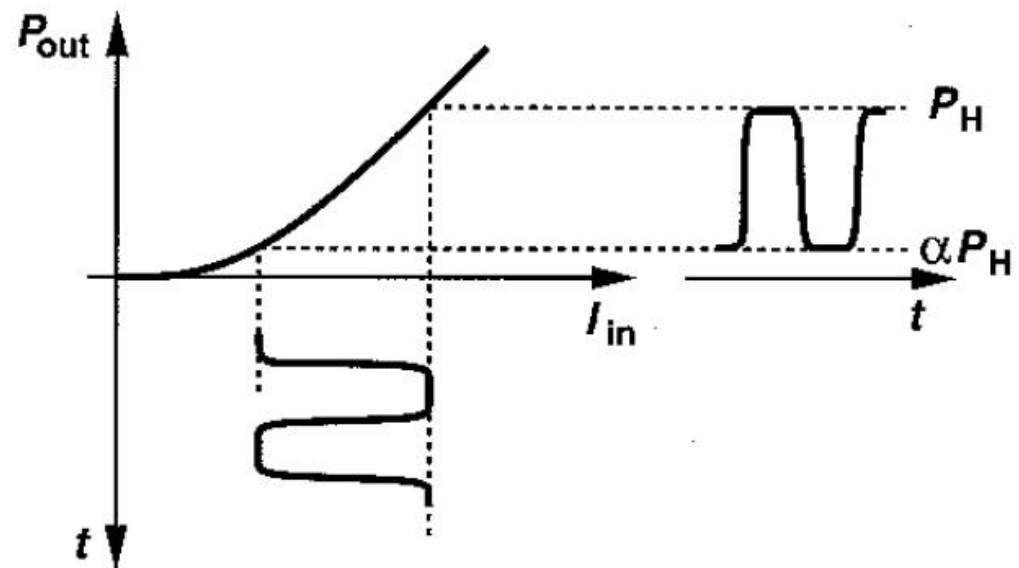

Modulație optică

- ▶ Pentru viteze mari se prefera utilizarea emisiei continue și modularea optică a radiației
- ▶ În LiNbO_3 viteza luminii depinde de câmpul electric, ceea ce permite introducerea unui defazaj egal π
- ▶ Crește complexitatea circuitului de control
- ▶ Tensiuni de 4÷6 V necesare

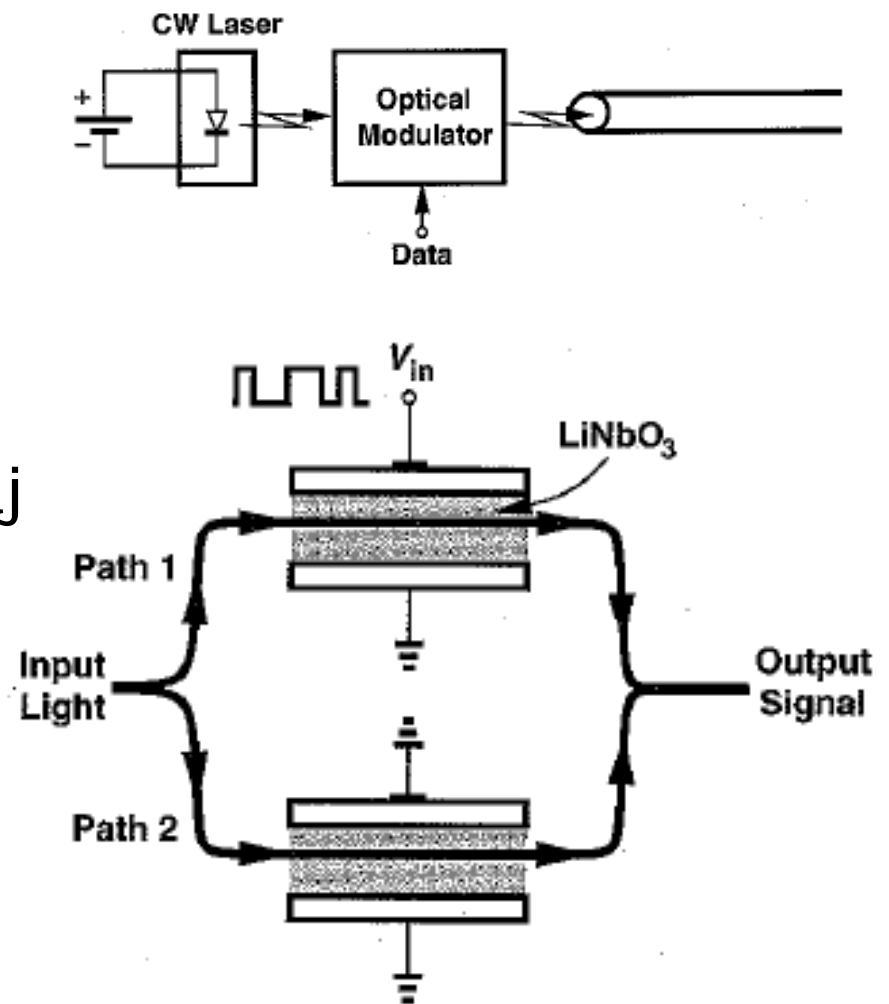

Dispozitiv termoelectric (Peltier)

- ▶ Jonctiunea intre doua materiale conductoare diferite poate genera sau absorbi caldura in functie de sensul curentului
- ▶ Tipic se utilizeaza doua regiuni semiconductoare puternic dopate (tipic telurit de bismut) conectate electric in serie iar termic in paralel

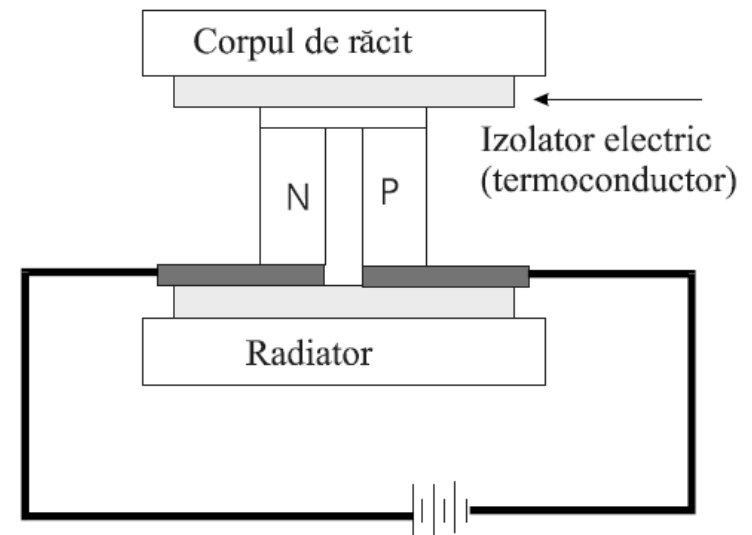

Dispozitiv termoelectric (Peltier)

- ▶ Poate produce o diferenta maxima de temperatura de 70°C
- ▶ Lucreaza la nivele mici de caldura disipata
- ▶ Devine cu atat mai ineficient cu cat fluxul termic disipat e mai mare
- ▶ De 4 ori mai putin eficiente decat sistemele cu compresie de vapori

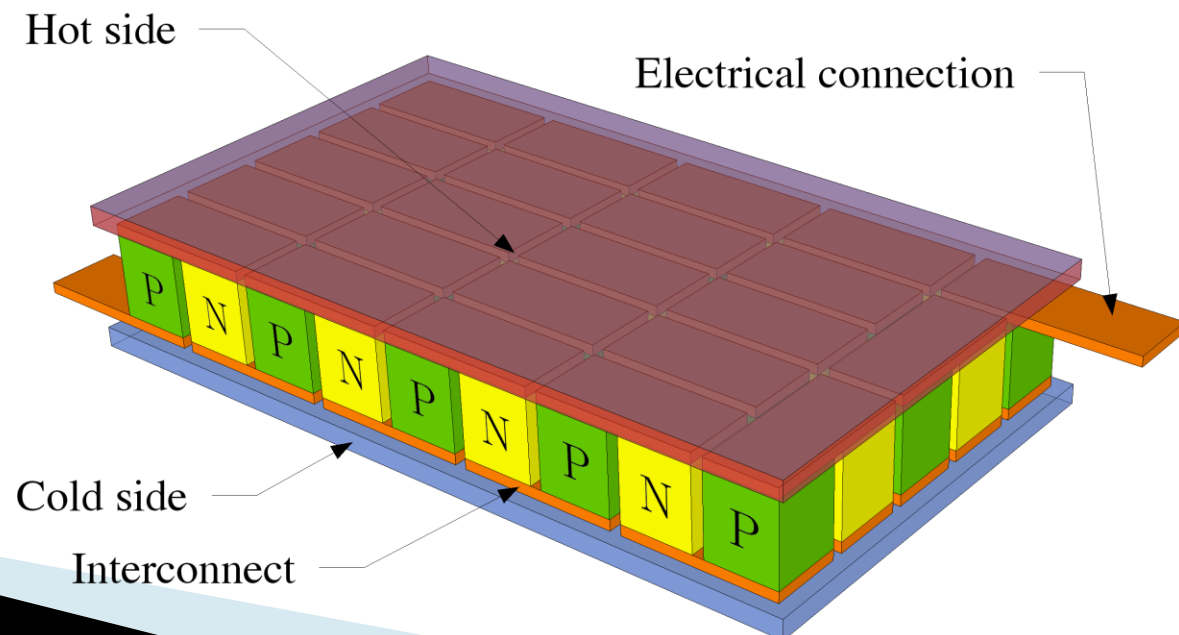

1550nm DFB Laser

Mechanical Drawing

All units in mm

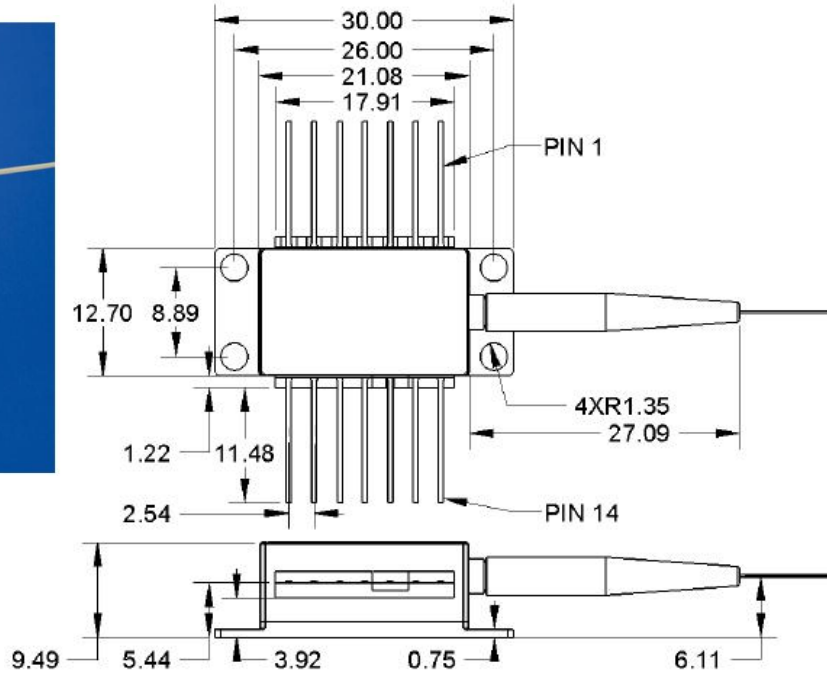

Pin out

Pin	Description
1	Thermistor
2	Thermistor
3	Laser Cathode (Bias)
4	Monitor PD Anode
5	Monitor PD Cathode
6	TEC +
7	TEC -
8	Case GND, Laser Anode
9	Case GND, Laser Anode
10	Case GND, Laser Anode
11	Case GND, Laser Anode
12	Laser Cathode (modulation)
13	Case GND, Laser Anode
14	Case GND, Laser Anode

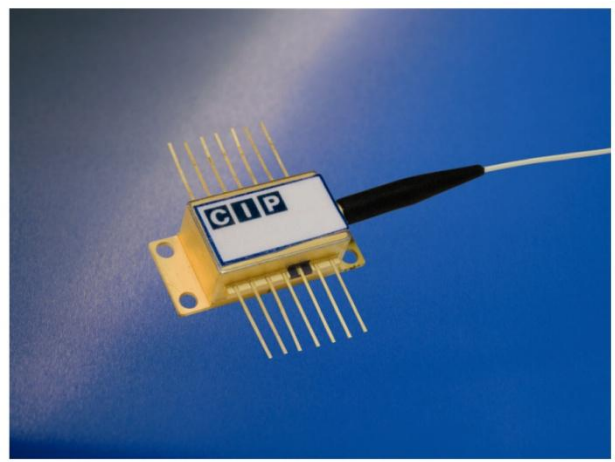

Control dioda LASER

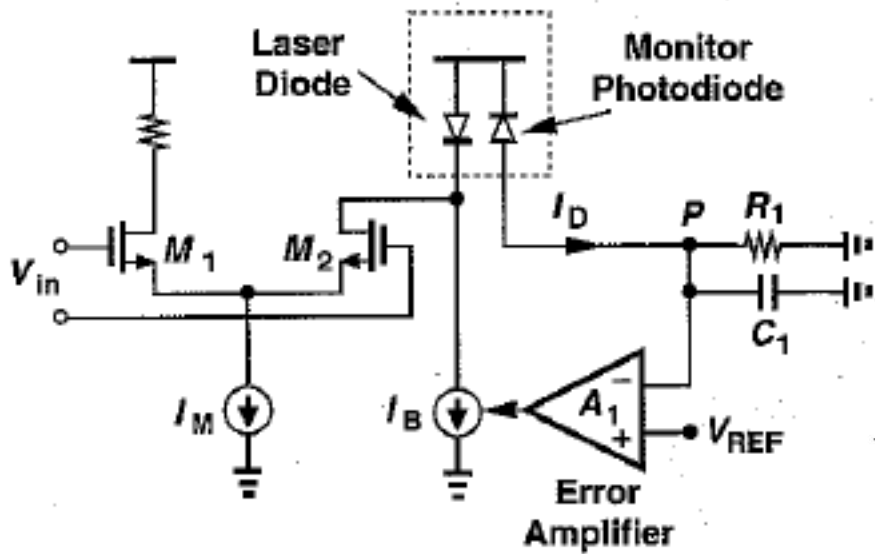

Control putere optica

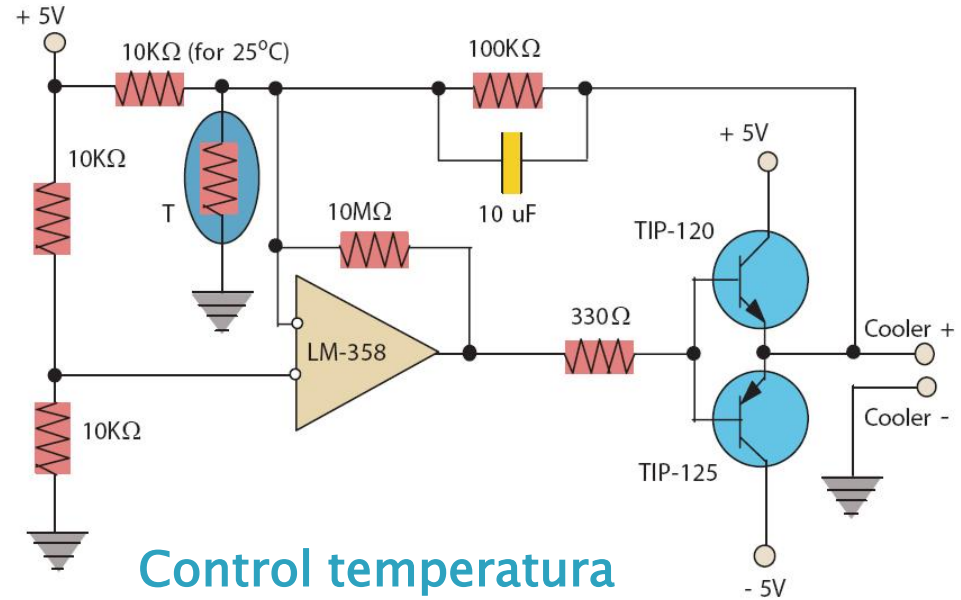

Control temperatura

Contact

- ▶ Laboratorul de microunde si optoelectronica
- ▶ <http://rf-opto.etti.tuiasi.ro>
- ▶ rdamian@etti.tuiasi.ro